



UL INTERNATIONAL (UK) LTD
 Womersley House, Building C,
 The Guildway,
 Old Portsmouth Road,
 Guildford. GU3 1LR.
 United Kingdom.



designated according to Article 29 of the Regulation (EU) No 305/2011 and member of EOTA (European Organisation for Technical Assessment, www.eota.eu)

European Technical Assessment

ETA 17/0836
of 30/04/2018

Technical Assessment Body issuing the ETA and designated according to Article 29 of the Regulation (EU) No 305/2011: UL International (UK) Ltd

Trade name of the construction product

MULCOL® MULTICOLLAR SLIM

Product family to which the construction product belongs

Fire Stopping and Sealing Product:

- Penetration Seals

Manufacturer

Mulcol International BV
 Arnesteinweg 18
 4338 PD Middelburg
 The Netherlands



Manufacturing plant(s)

L/001

This European Technical Assessment contains

248 pages including 1 Annex which forms an integral part of this assessment.

This European Technical Assessment is issued in accordance with regulation (EU) No 305/2011, on the basis of

EAD 350454-00-1104

Translations of this European Technical Assessment in other languages shall fully correspond to the original issued document and should be identified as such.

Communication of this European Technical Assessment, including transmission by electronic means, shall be in full. However, partial reproduction may be made, with the written consent of the issuing Technical Assessment Body. Any partial reproduction has to be identified as such.

Contents

I.	SPECIFIC PARTS OF THE EUROPEAN TECHNICAL ASSESSMENT	6
1	Technical description of the product	6
2	Specification of the intended uses of the product in accordance with the applicable European Assessment Document (Hereinafter EAD): EAD 350454-00-1104	8
3	Performance of the product and references to the methods used for its assessment	11
4	ASSESSMENT AND VERIFICATION OF CONSTANCY OF PERFORMANCE (HEREINAFTER AVCP) SYSTEM APPLIED, WITH REFERENCE TO ITS LEGAL BASE	12
5	Technical details necessary for the implementation of the AVCP system, as provided for in the applicable EAD	12
6	Issued on:.....	13
ANNEX A – Resistance to Fire Classification – Mulcol® Multicollar Slim - Flexible or rigid wall constructions according to Section 2.1) with wall thickness of minimum 100 mm		14
A.1	Plastic pipes.....	14
A.1.1	Plastic pipes in regular configurations	14
A.1.1.1	Plastic pipes fitted perpendicular to the wall.....	14
A.1.1.2	Plastic pipes fitted at angles 45°-90° to the wall.....	32
A.1.1.3	Plastic pipes, perpendicular to the wall, in Mulcol® Multimastic FB1 coated board seals	37
A.1.1.4	Plastic pipes insulated with AF/Armaflex made out of flexible elastomeric EPDM rubber foam	39
A.1.1.5	Plastic pipes insulated with AF/Armaflex made out of flexible elastomeric EPDM rubber foam	41
A.1.2	Plastic pipes pipes with sockets	43
A.1.2.1	Plastic pipes with (electrofusion) pipe coupling.....	43
A.1.3	Plastic pipes pipes with elbows.....	45
A.1.3.1	Plastic pipes with an elbow, perpendicular to the wall	45
A.1.3.2	Plastic pipes with an elbow, perpendicular to the wall, with one Mulcol® Multicollar <i>Slim</i> in an ‘U’ shape.....	47
A.1.4	Plastic pipes pipes with zero distance to the floor	49
A.1.4.1	Plastic pipes, perpendicular to the wall, in wall corner	49
A.1.4.2	Plastic pipes, perpendicular to the wall	51
A.1.5	Plastic pipes in conduits.....	53
A.1.6	Plastic pipes supported by steel half shells	55
A.1.6.1	Plastic pipes supported by steel supporting half shell, perpendicular to the wall	55
A.2	Plastic Pipes (Silent)	57
A.2.1	Pipes Pipes (Silent) in regular configurations	57
A.2.1.1	Plastic Pipes (silent), perpendicular to the wall	57
A.2.2	Plastic Pipes (Silent) with sockets	60
A.2.2.1	Plastic Pipes (silent) with moulded socket, perpendicular to the wall	60
A.2.3	Plastic Pipes (Silent) with an elbow.....	62
A.2.3.1	Plastic pipes (silent) with an elbow, perpendicular to the wall, with one Mulcol® Multicollar <i>Slim</i> in an ‘U’ shape.....	62
A.2.4	Plastic Pipes (Silent) with zero distance to the floor	64
A.2.4.1	Plastic pipes (silent), perpendicular to the wall, in wall corner	64
A.3	PP-R multilayer pipes	66
A.3.1	PP-R multilayer pipes in regular configurations	66
A.3.1.1	PP-R multilayer pipes, perpendicular to the wall	66
A.3.1.2	PP-R multilayer pipes, perpendicular to the wall, in Mulcol® Multimastic FB1 coated board seals	69
A.3.1.3	PP-R multilayer pipes insulated with AF/Armaflex made out of flexible elastomeric EPDM rubber foam	71
A.3.1.4	PP-R multilayer pipes insulated with AF/Armaflex made out of flexible elastomeric EPDM rubber foam	73

A.3.1.5	PP-R multilayer pipes insulated with AF/Armaflex made out of flexible elastomeric EPDM rubber foam, in Mulcol® Multimastic FB1 coated board seals	76
A.3.2	PP-R multilayer pipes supported by steel supporting half shell	78
A.3.2.1	PP-R multilayer pipes supported by steel supporting half shell, perpendicular to the wall.	78
A.3.3	PP-R multilayer pipes with an elbow.....	80
A.3.3.1	PP-R multilayer pipes with an elbow, perpendicular to the wall.....	80
A.3.4	PP-R multilayer pipes with zero distance to the floor	82
A.3.4.1	PP-R multilayer pipes, perpendicular to the wall	82
A.4.4.2	PP-R multilayer pipes insulated with AF/Armaflex made out of flexible elastomeric EPDM rubber foam	84
A.4	Aluminium composite pipes.....	86
A.4.1	Aluminium composite pipes in regular configurations.....	86
A.4.1.1	Aluminium composite pipes fitted perpendicular to the wall	86
A.4.1.2	Aluminium composite pipes fitted perpendicular to the wall, in Mulcol® Multimastic FB1 coated board seals	89
A.4.1.3	Aluminium composite pipes with PE-conduit insulation	92
A.4.1.4	Aluminium composite pipes insulated with PE-foam.....	94
A.4.1.5	Aluminium composite pipes insulated with AF/Armaflex made out of flexible elastomeric EPDM rubber foam	96
A.4.1.6	Aluminium composite pipes insulated with AF/Armaflex made out of flexible elastomeric EPDM rubber foam, in Mulcol® Multimastic FB1 coated board seals.....	98
A.4.2	Aluminium composite pipes with zero distance to the floor	100
A.4.2.1	Aluminium composite pipes, perpendicular to the wall.....	100
A.4.2.2	Aluminium composite pipes insulated with AF/Armaflex made out of flexible elastomeric EPDM rubber foam	102
A.4.2.3	2 x Aluminium composite pipes insulated with AF/Armaflex made out of flexible elastomeric EPDM rubber foam	104
A.4.2.4	Up to 5 x Aluminium composite pipes insulated with PE foam or AF/Armaflex or PE conduit	106
A.5	Multiple services in a single collar	108
A.5.1	Mixed pipes and cables in regular configurations	108
A.5.1.1	Up to 3 x mixed pipes and cables, perpendicular to the wall.....	108
A.5.1.2	Up to 3 x mixed pipes and cables, with insulation of AF/Armaflex.	110
A.5.1.3	Up to 3 x mixed pipes and cables, with insulation of PE foam	112
A.5.2	Multiple pipes in regular configurations	114
A.5.2.1	Up to 3 x plastic pipes, perpendicular to the wall	114
A.5.2.2	Up to 4 x Aluminium composite pipes, with insulation of PE foam.....	116
A.5.2.3	Up to 2 x Aluminium composite pipes with PE-foam, in Mulcol® Multimastic FB1 coated board seals	118
A.5.3	Multiple pipes with zero distance to the floor	120
A.5.3.1	Up to 5 x Aluminium composite pipes insulated with PE foam or AF/Armaflex or PE conduit	120
A.5.3.2	2 x Aluminium composite pipes insulated with AF/Armaflex	122
A.6	Flue Gas Pipes.....	124
A.6.1	Flue Gas Pipes in regular configurations	124
A.6.1.1	Aluminium flue gas pipes fitted perpendicular to the wall	124
A.6.1.2	Concentric steel flue gas pipes fitted perpendicular to the wall	126
A.6.1.3	Plastic flue gas pipes fitted perpendicular to the wall.....	128
A.6.1.4	Concentric plastic flue gas pipes fitted perpendicular to the wall.....	130
A.7	Electrical cables	131

A.7.1	Electrical cables in regular configurations.....	132
A.7.1.1	PVC pipes containing electrical cables	132
A.7.1.2	Electrical cables, fitted perpendicular to the wall	134
A.7.1.3	PE conduits containing electrical cables, fitted perpendicular to the wall	136
A.8	Metal pipes.....	138
A.8.1	Metal pipes in regular configurations	138
A.8.1.1	Metal pipes insulated with AF/Armaflex made out of flexible elastomeric EPDM rubber foam.....	138
A.8.1.2	Metal pipes insulated with AF/Armaflex made out of flexible elastomeric EPDM rubber foam.....	144
A.8.1.3	Metal pipes insulated with AF/Armaflex made out of flexible elastomeric EPDM rubber foam	146
A.8.1.4	Metal pipes insulated with PIR or PUR foam.....	148
A.8.1.5	Metal pipes insulated with PIR or PUR foam.....	149
Annex B - Resistance to Fire Classification – Mulcol® Multicollar Slim - Rigid floor constructions according to Section 2 1) with floor thickness of minimum 150 mm		151
B.1	Plastic pipes.....	151
B.1.1	Plastic pipes in regular configurations	151
B.1.1.1	Plastic pipes fitted perpendicular to the floor.....	152
B.1.1.2	Plastic pipes fitted at angles 45°-90° to the floor	166
B.1.1.3	Plastic pipes, perpendicular to the floor, in Mulcol® Multimastic FB1 coated board seals	170
B.1.1.4	Plastic pipes insulated with AF/Armaflex made out of flexible elastomeric EPDM rubber foam	173
B.1.2	Plastic pipes recessed into the soffit.....	175
B.1.2.1	Plastic pipes fitted perpendicular to the floor.....	175
B.1.3	Plastic pipes with an (electrofushion) pipe coupling.....	177
B.1.3.1	Plastic pipes with (electrofushion) pipe coupling fitted perpendicular to the floor	177
B.1.4	Plastic pipes with elbows	179
B.1.4.1	Plastic pipes with an elbow, perpendicular to the floor, with one Mulcol® Multicollar <i>Slim</i> in an 'U' shape.....	179
B.1.5	Plastic pipes with zero distance to the wall	181
B.1.5.1	Plastic pipes, perpendicular to the floor	181
B.2	Plastic pipes (Silent)	183
B.2.1	Plastic pipes (Silent) in regular configurations	183
B.2.1.1	Plastic pipes (silent), perpendicular to the floor	183
B.2.1.2	Plastic pipes (silent) fitted at angles 45°-90° to the floor	186
B.2.1.3	Plastic pipes (silent), perpendicular to the floor, in Mulcol® Multimastic FB1 coated board seals	188
B.2.2	Plastic pipes (Silent) with moulded socket or expansion pipe coupling	190
B.2.2.1	Plastic pipes (silent) with moulded socket or expansion pipe coupling	190
B.2.3	Plastic pipes (Silent) with an elbow.....	192
B.2.3.1	Plastic pipes (silent) with an elbow, perpendicular to the floor	192
B.2.3.2	Plastic pipes (silent) with an elbow, perpendicular to the floor, with one Mulcol® Multicollar <i>Slim</i> in an 'U' shape.....	194
B.2.4	Plastic pipes (Silent) with zero distance to the wall	196
B.2.4.1	Plastic pipes (silent), perpendicular to the floor	196

B.3	PP-R multilayer pipes	199
B.2.1	PP-R multilayer pipes in regular configurations.....	199
B.3.1.1	PP-R multilayer pipes, perpendicular to the floor	198
B.3.1.2	PP-R multilayer pipes, perpendicular to the floor, in Mulcol® Multimastic FB1 coated board seals	202
B.3.1.3	PP-R multilayer pipes insulated with AF/Armaflex made out of flexible elastomeric EPDM rubber foam	204
B.3.2	PP-R multilayer pipes with zero distance to the wall	206
B.3.2.1	PP-R multilayer pipes, perpendicular to the floor	206
B.4	Aluminium composite pipes	208
B.4.1	Aluminium composite pipes in regular configurations.....	208
B.4.1.1	Aluminium composite pipes fitted perpendicular to the floor	208
B.4.1.2	Aluminium composite pipes fitted perpendicular to the floor	210
B.4.1.3	Aluminium composite pipes insulated with PE-foam.....	212
B.4.1.4	Aluminium composite pipes insulated with AF/Armaflex made out of flexible elastomeric EPDM rubber foam	214
B.4.1.5	Aluminium composite pipes in PE conduit.....	216
B.4.1.6	Up to 4 x Aluminium composite pipes insulated with PE-foam.....	218
B.5	Multiple services in a double collar	220
B.5.1	Mixed pipes and cables in regular configurations	220
B.5.1.1	Up to 3 x mixed pipes and cables.....	220
B.5.1.2	Up to 3 x mixed pipes and cables, insulated with PE-foam	222
B.5.1.3	Up to 4 x Aluminium composite pipes insulated with PE-foam.....	224
B.6	Electrical cables	226
B.6.1	Electrical cables in regular configurations.....	226
B.6.1.1	Electrical cables, fitted perpendicular to the floor	226
B.6.1.2	PE conduits containing electrical cables, fitted perpendicular to the floor	228
B.6.1.3	PVC pipes containing electrical cables, fitted perpendicular to the floor.....	230
B.7	Flue Gas Pipes.....	232
B.7.1	Flue Gas Pipes in regular configurations	232
B.7.1.1	Aluminium flue gas pipes fitted perpendicular to the floor	232
B.7.1.2	Concentric steel flue gas pipes fitted perpendicular to the floor	234
B.7.1.3	Plastic flue gas pipes fitted perpendicular to the floor	236
B.7.1.4	Concentric plastic flue gas pipes fitted perpendicular to the floor	238
B.8	Metal pipes.....	240
B.8.1	Metal pipes in regular configurations	240
B.8.1.1	Metal pipes fitted perpendicular to the floor	240
B.8.1.2	Metal pipes insulated with AF/Armaflex made out of flexible elastomeric EPDM rubber foam	242
B.8.1.3	Metal pipes insulated with AF/Armaflex made out of flexible elastomeric EPDM rubber foam	244
B.8.1.4	Metal pipes, perpendicular to the floor, in Mulcol® Multimastic FB1 coated board seals	247

I. SPECIFIC PARTS OF THE EUROPEAN TECHNICAL ASSESSMENT

1 Technical description of the product

- 1) Mulcol® Multicollar *Slim* is a pipe collar device used to form penetration seals where plastic pipes Flue Gas pipes, aluminium composite pipes and metal pipes, with and without insulation and cables penetrate walls and floors.
- 2) The Mulcol® Multicollar *Slim* is supplied with 30 x 12 mm intumescent liner complete within a stainless steel shell, to be closed around the services and fixed to the supporting element.
- 3) Services penetrating the Mulcol® Multicollar *Slim* are required to be supported at maximum 450 mm from both faces of walls and from the top face of floors.
- 4) The permitted annular spaces for the services/seals are indicated below (other configurations specific dimensions are given in Annex A:

Filling material (a ₁)		Annular space between pipe/insulation and collar		Minimum distance between aperture edges, distance A2
Mulcol® Multimortar	Mulcol® Multisealant A or Multimastic SP both faces	Outer diameter ≤ 125 mm / 'a' ≤ 15 mm	Outer diameter > 125 mm / 'a' ≤ 5 mm	
Annular gap ≥ 10 mm / / depth fully filled	Annular gap ≤ 20 mm / depth ≥ 10 mm			100 mm

Visualisation of annular space and separation between penetration seals

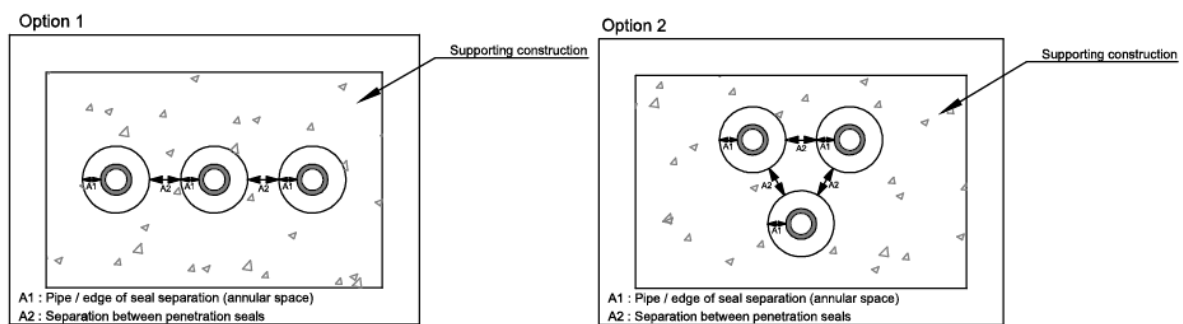

In the Mulcol® Multimastic FB1 system the following minimum distances between the apertures edges and between the pipes shall be applied (distance A₁ to A₃ according to Figure E.1 of EN 1366-3: 2009, See Figure 2):

- distance A₁ = 50 mm;
- distance A₂ = 50 mm;
- distance A₃ = 100 mm.

Figure 2 Figure E.1 of EN 1366-3: 2009

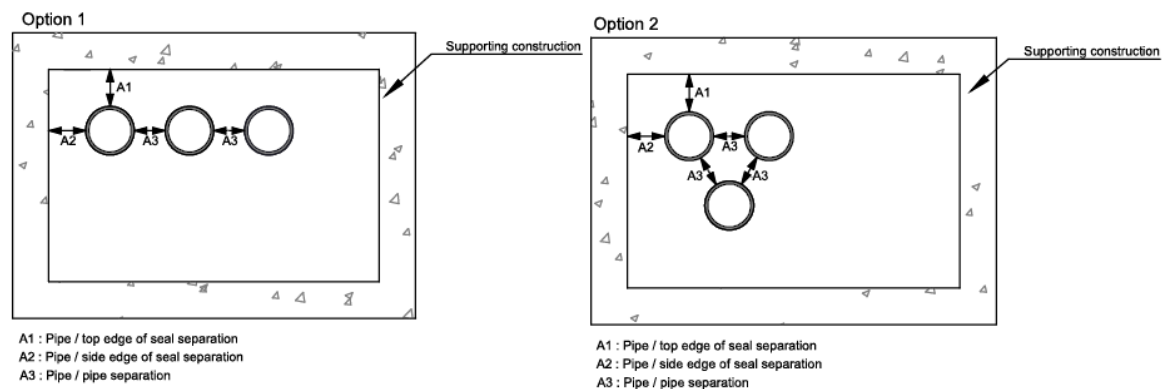

- 5) The following products and fixings are used in conjunction with Mulcol® Multicollar *Slim* to form the penetration seal:
- Mulcol® Multimortar (floor);
 - Mulcol® Multisealant A (wall and floor);
 - Mulcol® Multisealant A with backing rockwool $\geq 35 \text{ kg/m}^3$ (floor);
 - Mulcol® Multimastic SP (wall and floor).

Outer diameter pipe, cable or insulation (mm)	Single Collar	Double Collar		Allowed Fixings		
	Number of Mulcol® Multiclips	First collar (Mulcol® Multiclips)	Second collar (Mulcol® Multiclips Large)	Rigid wall	Flexible Wall	Coated Firestop board system
≤ 90	2	1*	2	Mulcol® Multiscrew 7,5 x 40 mm	Mulcol® Multiscrew 7,5 x 40 mm or threaded rod and bolts M6	Mulcol® Multiscrew FB 40 or threaded rod and bolts M6
> 90 and < 160	3	1*	3			
≥ 160 and ≤ 200	4	1*	4			
> 200 and ≤ 285	5	2	5			
> 285 and ≤ 315	6	2	6			

*Mechanical fixation to the wall is not necessary

- 6) Pipe materials referred to in Annex A are as follows:

Material	Standards
PVC-U	DIN 8061 / DIN 8062 / DIN 19531-10 / EN 1329-1 / EN 1452-1 / EN 1453-1 / EN ISO 15493
PVC-C	EN 1566-1 / EN ISO 15493
PP	DIN 8077 / DIN 8078 / DIN 16962 / EN 1451-1 / EN 15874-2 / EN ISO 15494 / EN 15874 / EN 15874-2 / EN 15874-2:2013
PE	DIN 8074 / DIN 8075 / EN 1519-1 / EN 12201-2 / EN 12666-1 / EN ISO 15494
PE-HD	DIN 19535-10 / EN 1519-1 / EN 12666-1
ABS	EN 1455-1 / EN ISO 15493
SAN+PVC	EN 1565-1
Steel	EN 1507
Copper	EN 10255 / EN 12449
PP-R	DIN 8077 / DIN 8078
Aluminium Composite	EN ISO 15494

- 7) The applicant has submitted a written declaration that the product and/or constituents of the product contains no substances which have been classified as dangerous according to Directive 67/548/EEC and Regulation (EC) No. 1272/2008 and listed in the 'indicative list on dangerous substances' of the EGDS – taking into account the installation conditions of the construction product and the release scenarios resulting from there.

In addition to the specific clauses relating to dangerous substances contained in this European Technical Assessment, there may be other requirements applicable to the products falling within its scope (e.g. transposed European legislation and national laws, regulations and administrative provisions). In order to meet the provisions of the Construction Products Regulation, these requirements need also to be complied with, when and where they apply.

- 8) The use category of Mulcol® Multicollar *Slim* in relation to BWR 3 (Hygiene, health and environment) is IA1, S/W3

2 Specification of the intended uses of the product in accordance with the applicable European Assessment Document (Hereinafter EAD): EAD 350454-00-1104

Detailed information and data is given in Annex A.

The intended use of system Mulcol® Multicollar *Slim* is to reinstate the fire resistance performance of flexible wall and rigid wall and floor constructions, where they are penetrated by services.

- 1) The specific elements of construction that the system Mulcol® Multicollar *Slim* may be used to provide a penetration seal in, are as follows:

Flexible walls: The wall must have a minimum thickness of 100 mm and comprise steel studs lined on both faces with minimum 2 layers of 12.5 mm thick boards.

Rigid walls: The wall must have a minimum thickness of 100 mm and comprise concrete, aerated concrete or masonry, with a minimum density of 650 kg/m³.

Rigid floors: The floor must have a minimum thickness of 150 mm and comprise aerated concrete or concrete with a minimum density of 600±200 kg/m³, class G4/600 or heavier.

The supporting construction must be classified in accordance with EN 13501-2 for the required fire resistance period.

- 2) General conditions – Flexible wall
The pipe and cable penetrations can be applied in any type of insulated or non insulated flexible all construction (partition) provided that the following conditions are met. The total thickness of the flexible wall (for example walls with wooden or steel framing) shall be at least 100 mm. The wall shall consist out of in total four board layers with a thickness of 12.5 mm each. A minimum distance of 100 mm to a stud shall be held. When wooden studs are used, at least 100 mm of insulation class A1 or A2 according to EN 13501-2 shall be present between the penetration seal and the stud(s).
- 3) General conditions – distance of metal strap collar to wall, corner or floor
Except for pipe penetrations placed at a zero distance to the floor and the pipe penetrations placed in a corner, a distance of at least 10 mm from the metal strap of the collar to a different wall, corner, floor or transfer to another type of wall (adjacent constructions) shall be taken into account to enable a proper working of the intumescent inlay.
- 4) General conditions – Mixed Penetration Seals – Multiple Mulcol® Multicollar *Slim* devices with the same or different services, may be incorporated in coated firestop board system Mulcol® Multimastic FB1 subject to the conditions specified in Annex A. The performance of the seal is restricted to the contained service/Mulcol® Multicollar *Slim* device with the lowest classification, as given in Annex A.
- 5) The system Mulcol® Multicollar *Slim* may be used to provide a penetration seal with specific supporting constructions and substrates (for details see Annex A).
- 6) The provisions made in this European Technical Assessment are based on an assumed working life of the Mulcol® Multicollar *Slim* of 30 years, provided that the conditions laid down in the manufacturers datasheet and instructions for the packaging/transport/storage/installation/ use/repair are met. The indications given on the working life cannot be interpreted as a guarantee given by the producer, but are to be regarded only as a means for choosing the right products in relation to the expected economically reasonable working life of the works.
- 7) Type Z₁: intended for use at internal conditions with high humidity, excluding temperatures below 0°C.

8) General Conditions – Installation in coated firestop board system – Mulcol® Multimastic FB1 (2x50 mm)

The aperture size in the floor may be up to 1200 mm wide and 2400 mm long. The Mulcol® Multimastic FB1 board system has a total thickness of 100 mm (2 x 50 mm) with a coating Mulcol® Multimastic C. The coating is applied with a thickness 1 mm on the outwards pointing faces of each panel (no coating between the boards). The coating shall also be applied circumferential over the opening of the rock wool with the adjacent construction (overlap minimal 25 mm). The joints between the different board elements and the aperture edge shall be glued together with Mulcol® Multimastic SP. A cavity of maximum 50 mm between the rock wool panels may be present.

For further information regarding the placing instructions and the field of application of the Mulcol® Multimastic FB1 (2 x 50 mm) penetration seal system reference is made to the European Technical Assessment ETA 16/0985 dated January 25, 2017 or ETA 16/0563 dated August 23, 2016.

The use of the Mulcol® Multimastic FB1 (2 x 50 mm) penetration seal system is recommended.

Mulcol® Multicollar *Slim* has been tested in several different penetration seal systems of other manufacturers such as Hensomastik®, Promastop® I and Promastop® CC. The manufacturer of stone wool penetration seal systems other than Mulcol® Multimastic FB1, should be consulted regarding installation instructions and fire resistance/field of application of the desired performance class in accordance with EN 13501-2 must be verified.

9) Insulation types

The following acoustic insulation types are allowed by standard plastic pipes:

- ABSound Sonocool Type PM;
- Jaco Massa Reinforced Alu, Jaco Massa Alu and Jaco Massa Black Alu;
- Merfisol Silver ALU

The following elastomeric insulation types are allowed:

- AF/Armaflex;
- SH/Armaflex;
- Kaiflex ST and Kaiflex KKplus s2;
- K-Flex EC, K-Flex EC AD, K-Flex EC, K-Flex ST, K-Flex ST/SK, K-Flex ST Frigo, K-Flex SRC and K-Flex SRC Eco.

The following thermal insulation types are allowed:

- Insul-Phen, Insul-Pirplus and Insul-Pir 33
- Kingspan Tarecpir M1, Kingspan Tarecpir CR, Kingspan Tarecpir B2, Kingspan Tarecpir HT, Kingspan Tarecpir HD and Kingspan Kooltherm FM.

10) Pipe types

The follow aluminium composite pipe types are allowed:

- Alpex DUO, Valsir Pexal, Valsir Mixal and APE Plain (PE-Xb/AL/PE-Xb);
- Uponor and Geberit Mepla (PE-RT/AL/PE-RT);
- Uponor and Henco (PE-Xc/AL/PE-Xc);
- Uponor and REHAU (PE-Xa) and REHAU (PE-Xc);
- SP Superpipe and POLYGON PEX (PE-X/AL/PE-X);
- Valsir Pexal and Valsir Mixal (PE/AL/PE-Xb);
- Wavin Tigris, Protecta-Line System and Alpex F50 Profi (PE-X/AL/PE).

The follow fiber composite pipe types (or equal) are allowed:

- Aquatechnik Fusio PP-R 80, Aquatechnik Fusio PP-RCT;
- Aquatherm Blue-MF, Aquatherm Blue-S, Aquatherm Red-MF, Aquatherm Green-MF, Aquatherm Green-MS, Aquatherm Green-S, Aquatherm Lilac-S, Aquatherm Grey-MS and Aquatherm Orange M;
- Bänninger PP-R, Bänninger Climatec PP-RCT and Bänninger Watertec PP-RCT.

The follow Low-noise (Silent) pipe types (or equal) are allowed:

- Coes PhoNoFire and Coestilen BluePower;
- Geberit Silent PP and Geberit Silent dB 20;
- Girpi Friaphon and Marley Silent;
- Pipelife Master 3 and PhonEX AS;
- Poloplast POLO-KAL NG and Poloplast POLO-KAL 3S;
- Skolan dB;
- Raupiano Plus;
- Valsir Triplus, Wavin SiTech+ and Wavin AS.
- DykaSono

11) General conditions pipe insulations

All foil faced pipe insulations with a self-adhesive edge do not require the installation of iron wires.

Pipe insulation without a self-adhesive edge must be provided with iron wires ≥ 0.6 mm.

Ratio per metre: 5 windings, with a minimum of 2

3 Performance of the product and references to the methods used for its assessment

Product Type: Pipe closure		Intended use: Penetration Seal
Assessment method	Essential characteristic	Product performance
BWR 2 Safety in case of fire		
EN 13501-1	Reaction to fire	Class 'E'
EN 13501-2	Resistance to fire	Annex A
BWR 3 Hygiene, health and environment		
EN 1026	Air permeability	No performance determined
EAD 350454-00-1104, Annex C	Water permeability	No performance determined
Declaration of manufacturer & EN 16516	Content, emission and/or release of dangerous substances	Use categories: IA1, S/W3 Declaration of manufacturer
BWR 4 Safety in use		
EOTA TR 001:2003	Mechanical resistance and stability	No performance determined
EOTA TR 001:2003	Resistance to impact/movement	
EOTA TR 001:2003	Adhesion	
EAD 350454-00-1104, Clause 2.2.9	Durability	Z ₁
BWR 5 Protection against noise		
EN 10140-1,2,4,5/ EN ISO 717-1	Airborne sound insulation	No performance determined
BWR 6 Energy economy and heat retention		
EN 12664, EN 12667, EN 12939, EN ISO 8990, EN ISO 6946, EN ISO 14683, EN ISO 10211, EN ISO 10456	Thermal properties	No performance determined
EN ISO 12572, EN 12086, EN ISO 10456	Water vapour permeability	No performance determined

4 ASSESSMENT AND VERIFICATION OF CONSTANCY OF PERFORMANCE (HEREINAFTER AVCP) SYSTEM APPLIED, WITH REFERENCE TO ITS LEGAL BASE

According to the decision 1999/454/EC – Commission Decision of date 22nd June 1999 on the procedure for attesting the conformity of construction products pursuant to Article 20(2) of Council Directive 89/106/EEC as regards fire stopping, fire sealing and fire protective products, published in the Official Journal of the European Union (OJEU) L178/52 of 14/07/1999, see <http://eur-lex.europa.eu/JOIndex.do>) of the European Commission¹, as amended, the system(s) of assessment and verification of constancy of performance (see Annex V to Regulation (EU) No 305/2011) given in the following table(s) applies (apply).

Product(s)	Intended use(s)	Level(s) or class(es)	System(s)
Fire stopping and Fire Sealing Products	For fire compartmentation and/or fire protection or fire performance	Any	1

5 Technical details necessary for the implementation of the AVCP system, as provided for in the applicable EAD

Tasks of the manufacturer:

Factory production control

The manufacturer shall exercise permanent internal control of production. All the elements, requirements and provisions adopted by the manufacturer shall be documented in a systematic manner in the form of written policies and procedures, including records of results performed. This production control system shall ensure that the product is in conformity with this European Technical Assessment.

The manufacturer may only use initial / raw / constituent materials stated in the technical documentation of this European Technical Assessment.

The factory production control shall be in accordance with the Control Plan of 9th August 2017 relating to the European Technical Assessment ETA 17/0836 issued on 30/04/18 which is part of the technical documentation of this European Technical Assessment. The "Control Plan" is laid down in the context of the factory production control system operated by the manufacturer and deposited at UL International (UK) Ltd.

The results of factory production control shall be recorded and evaluated in accordance with the provisions of the Control Plan.

¹ Official Journal of the European Communities L178/52 of 14/7/1999

Other tasks of the manufacturer

Additional information

The manufacturer shall provide a technical data sheet and an installation instruction with the following minimum information:

(a) Technical data sheet:

- Field of application:
- Building elements for which the penetration seal is suitable, type and properties of the building elements like minimum thickness, density, and - in case of lightweight constructions – the construction requirements.
- Limits in size, minimum thickness etc. of the penetration seal
- Construction of the penetration seal including the necessary components and additional products (e.g. backfilling material) with clear indication whether they are generic or specific.

(b) Installation instruction:

- Steps to be followed
- Procedure in case of retrofitting
- Stipulations on maintenance, repair and replacement

6 Issued on:

30th April 2018

Report by:



C. Johnson
Staff Engineer
Building and Life Safety Technologies

Reviewed by:



C. W. Miles
Business Manager – Europe & Latin America
Building and Life Safety Technologies

For and on behalf of UL International (UK) Ltd.

ANNEX A – Resistance to Fire Classification – Mulcol® Multicollar Slim - Flexible or rigid wall constructions according to Section 2 1) with wall thickness of minimum 100 mm

A.1 Plastic pipes

A.1.1 Plastic pipes in regular configurations

A.1.1.1 Plastic pipes fitted perpendicular to the wall, with one or two Mulcol® Multicollar Slim pipe collars to both sides of the wall.

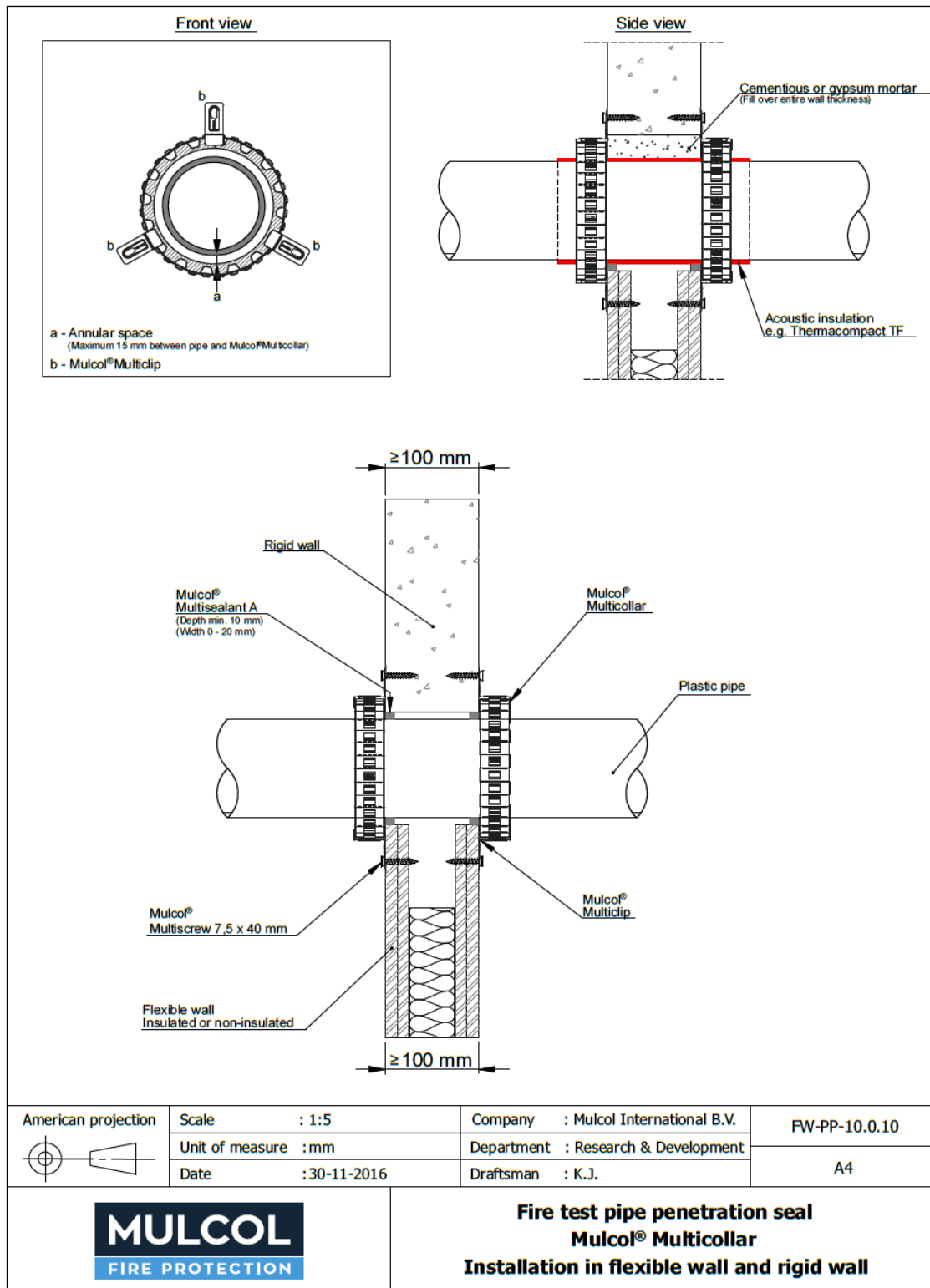

Front view

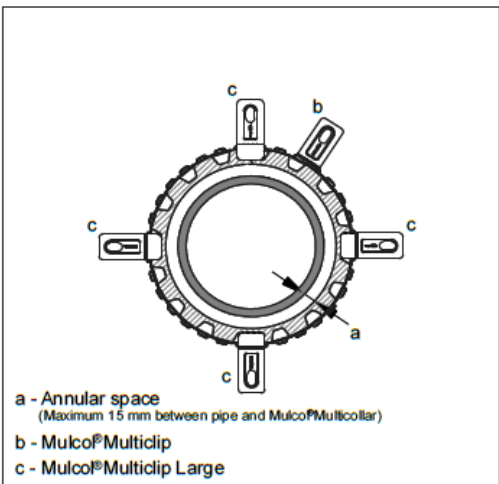

Side view

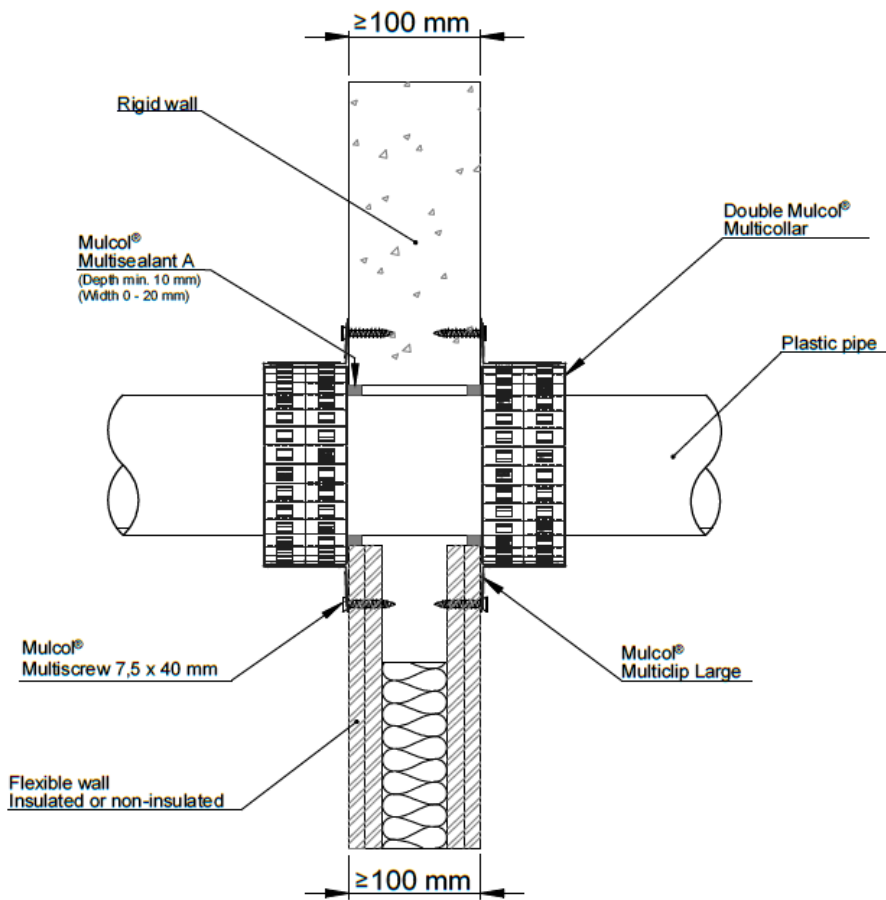
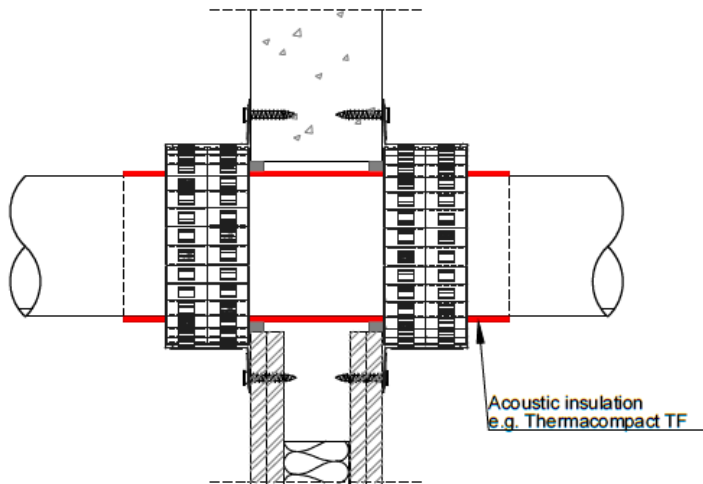

	Scale : 1:5	Company : Mulcol International B.V.	FW-PP-20.0.10
	Unit of measure : mm	Department : Research & Development	
	Date : 29-7-2016	Draftsman : K.J.	A4



**Fire test pipe penetration seal
Mulcol® Multicollar
Installation in flexible wall and rigid wall**

Front view

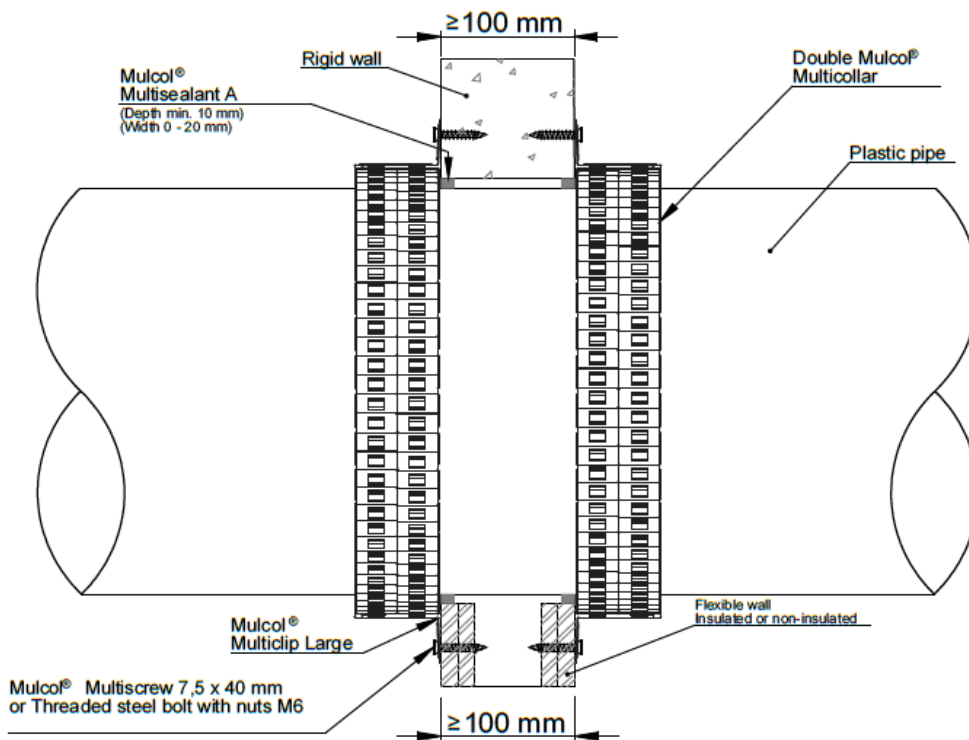
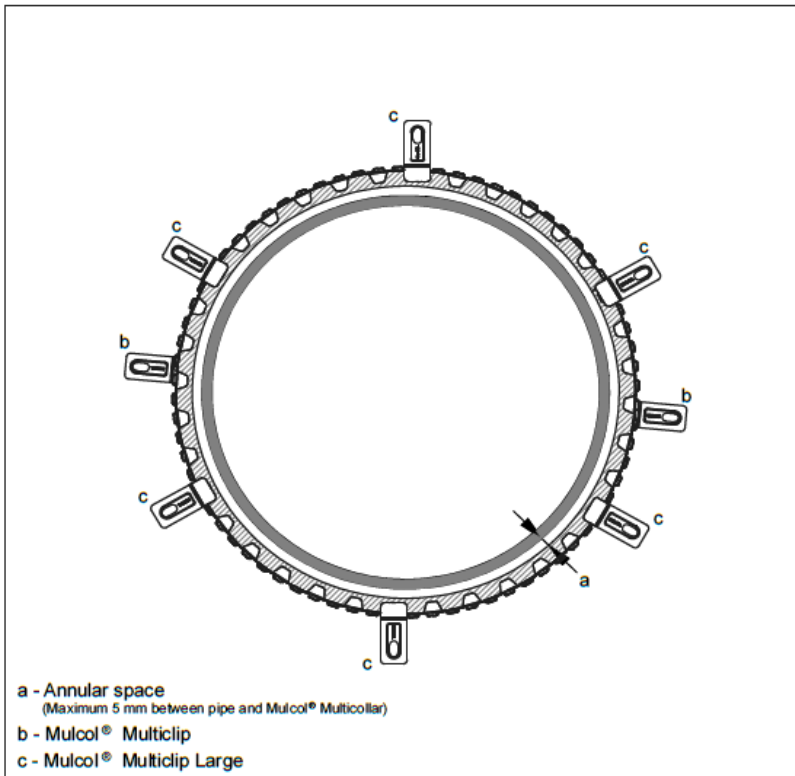

	Scale : 1:5	Company : Mulcol International B.V.	FW-PP-20.0.10
	Unit of measure : mm	Department : Research & Development	A4
	Date : 14-11-2016	Draftsman : K.J.	



Fire test pipe penetration seal
Mulcol® Multicollar
Installation in flexible wall and rigid wall

Pipe material [^]	Maximum pipe diameter mm	Pipe wall thickness mm	No. of collars per face	Classification*
PE-HD / PE / ABS / SAN+PVC	40	2.4-6.6	one	EI 120 U/U
		6.6-14.6		EI 90 U/C
	110	3.1-6.6		EI 120 U/U
		6.6-7.4		EI 90 U/U
		7.4-10.0		EI 60 U/U
		10.0-14.6		EI 30 U/U
		3.1-4.9		EI 120 U/U
	125	4.9-7.4		E 120 U/U EI 90 U/U
		7.4-11.4		EI 45 U/U
		11.4-14.6		EI 30 U/U
		7.4-14.6	EI 90 U/C	
		4.0-14.6	EI 90 U/C	
	160	4.0-9.5	two	EI 120 U/U
		9.5-14.6		EI 60 U/U
		9.5-14.6		EI 120 U/C
PP	40	6.3-9.1	one	EI 120 U/C
		1.8-6.3		EI 120 U/U
	110	2.7-6.3		EI 90 U/U
		6.3-7.1		EI 30 U/U
		7.1-14.6		EI 120 U/C
		2.7-9.1		EI 120 U/U
	125	3.1		E 120 U/U EI 90 U/U
		3.1-7.1		EI 30 U/U
		7.1-3.6		EI 120 U/C
		3.1-9.1		E 120 U/U EI 90 U/U
		4.0	E 60 U/U EI 45 U/U	
	160	4.0-6.2	EI 30 U/U	
		6.2-14.6	EI 120 U/C	
		9.1	EI 90 U/C	
		4.0-9.1	EI 120 U/U	
		4.0-9.1	two	EI 60 U/U
	9.1-14.6	EI 120 U/C		
	9.1-14.6			

Pipe material [^]	Maximum pipe diameter mm	Pipe wall thickness mm	No. of collars per face	Classification*
PVC-U / PVC-C	40	1.9-9.3	one	EI 120 U/U
		9.3-12.3		EI 90 U/U
		12.3-14.6		EI 30 U/U
	110	2.2-9.3		EI 120 U/U
		9.3-12.3		E 120 U/U EI 90 U/U
		12.3-14.6		EI 30 U/U
	125	2.5-9.3	one	EI 120 U/U
		9.3-11.8		EI 90 U/U
		11.8-14.6		EI 30 U/U
	160	1.8-11.8		E 120 U/U EI 90 U/U
		11.8-14.6		EI 30 U/U
		two		1.8-11.8
	11.8-14.6		EI 60 U/U	
	11.8-14.6		EI 120 U/C	
	315	7.7	EI 90 U/C	

* U/U pipe end configuration applies to U/C, C/U and C/C also

[^] Pipes may optionally be fitted with up to 4 mm thick sound decoupling insulation, min. 50 mm long (LS/CS/LI/CI)

Approved pipe range PE-HD / PE / ABS / SAN+PVC
EI 30-U/U and EI 30-U/C

One collar each face = grey area

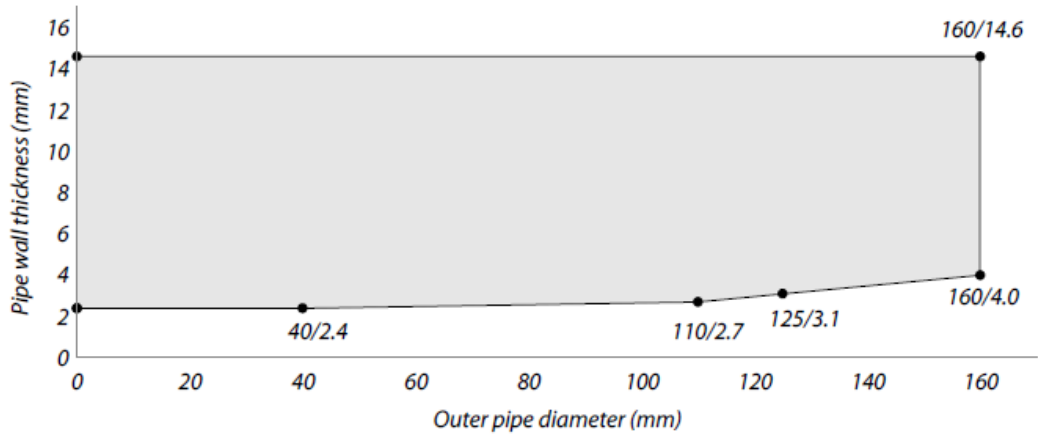

Approved pipe range PE-HD / PE / ABS / SAN+PVC
EI 45-U/U

One collar each face = grey area
Two collars each face = green area

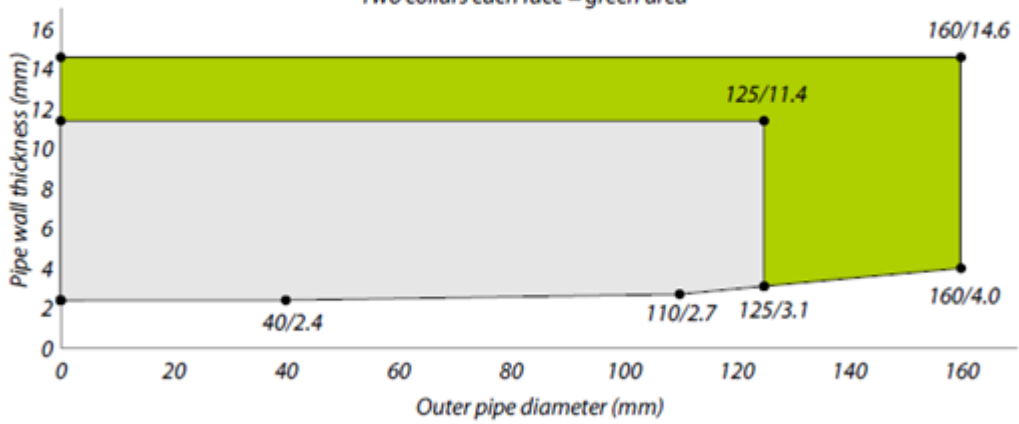

Approved pipe range PE-HD / PE / ABS / SAN+PVC
EI 45-U/C

One collar each face = grey area

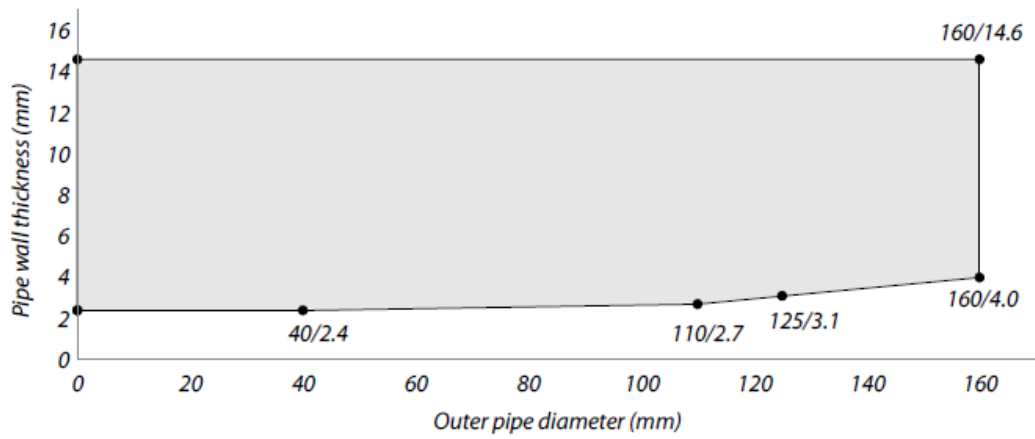

Approved pipe range PE-HD / PE / ABS / SAN+PVC
EI 60-U/U

One collar each face = grey area
Two collars each face = green area

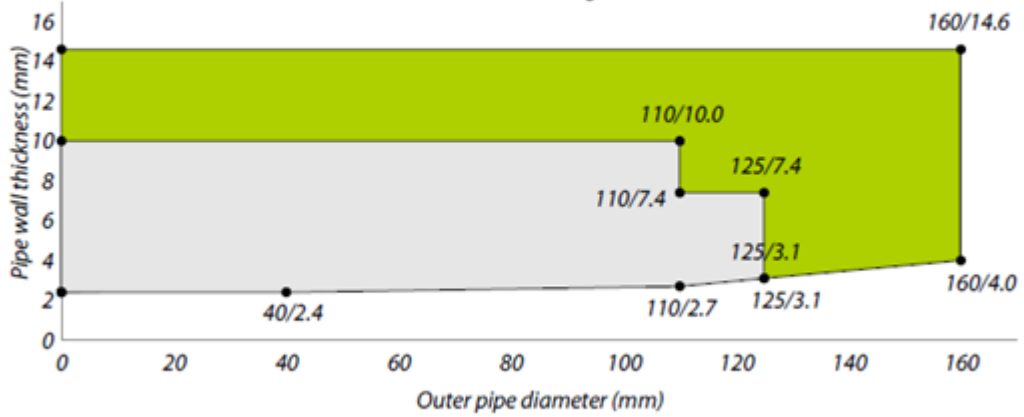

Approved pipe range PE-HD / PE / ABS / SAN+PVC
EI 60-U/C

One collar each face = grey area

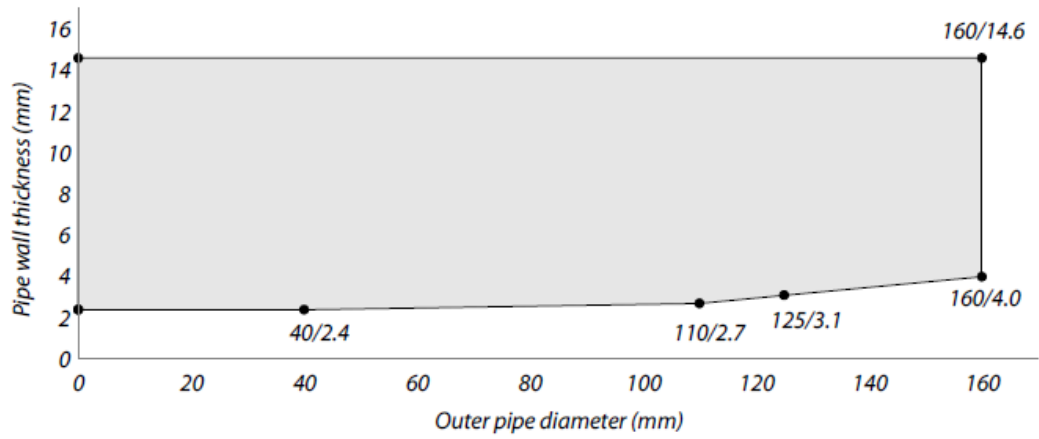

Approved pipe range PE-HD / PE / ABS / SAN+PVC
EI 90-U/U

One collar each face = grey area
Two collars each face = green area

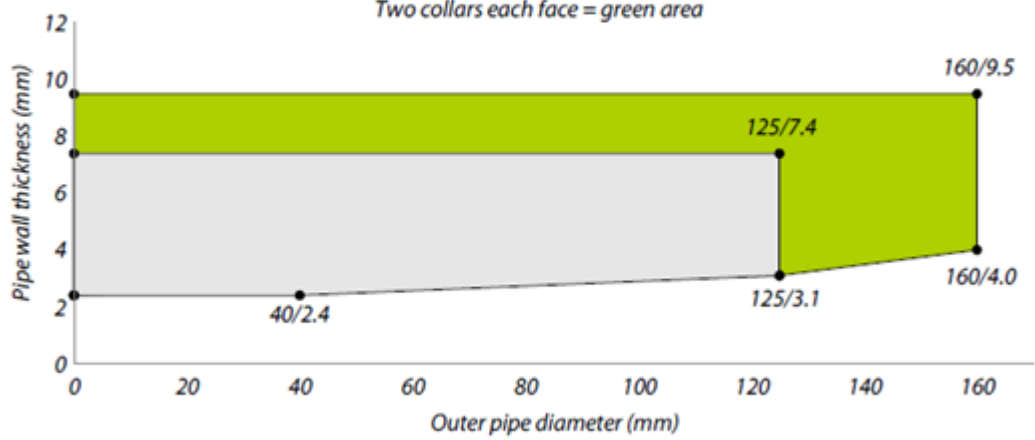

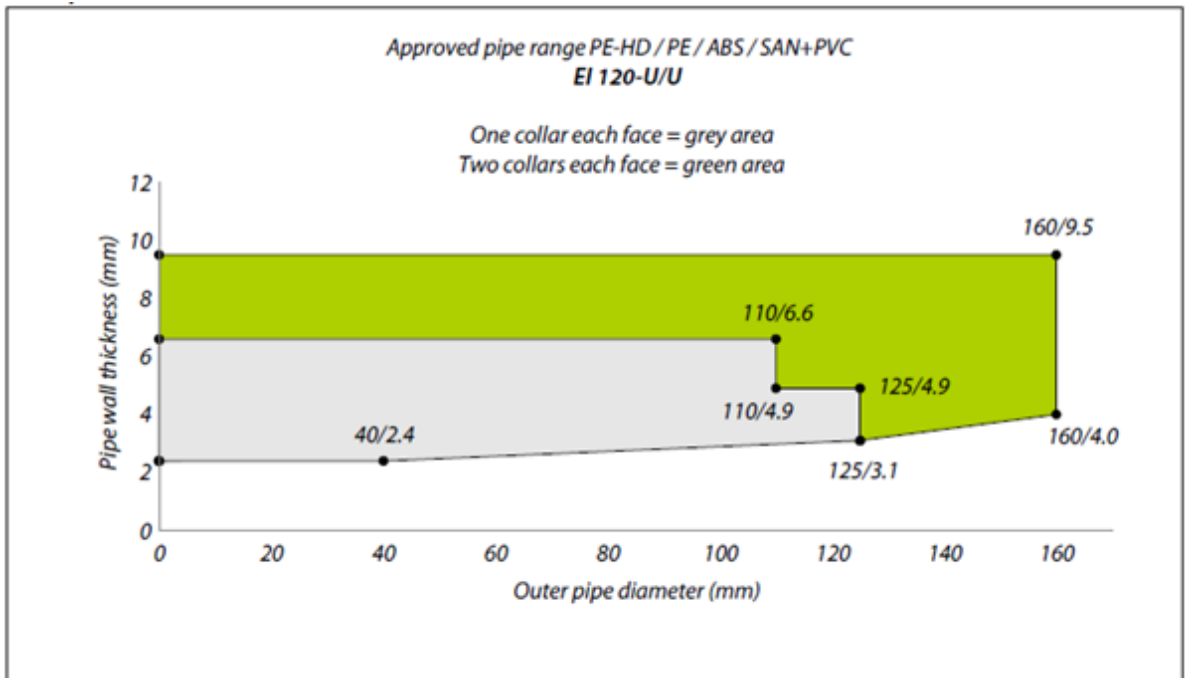
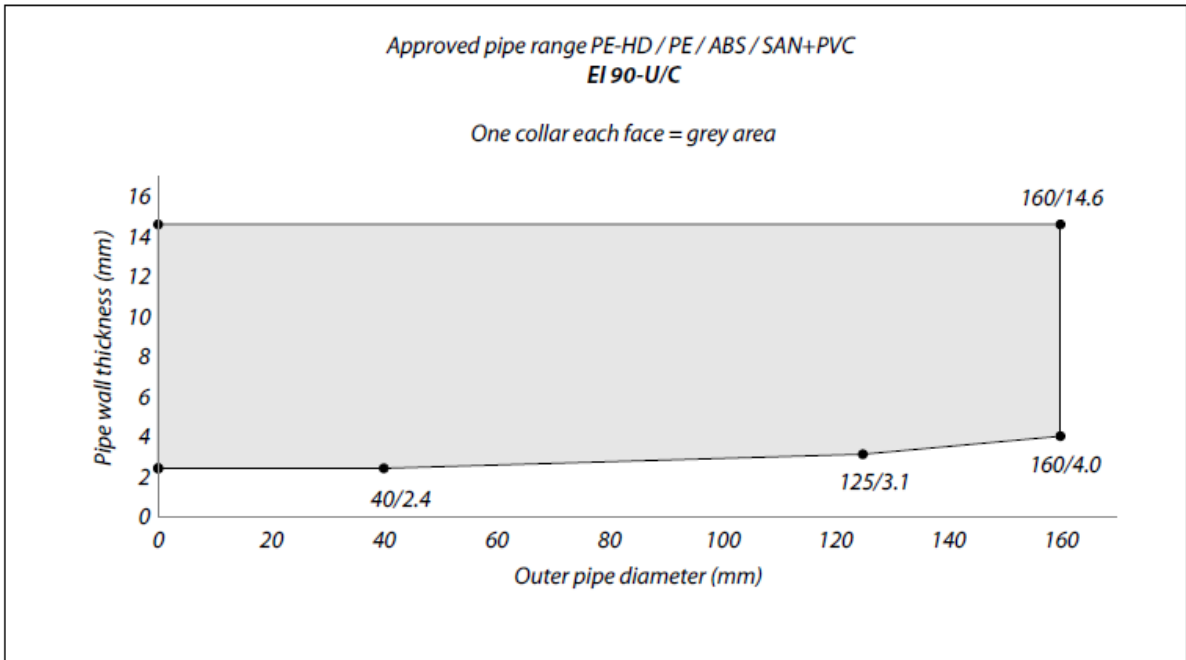

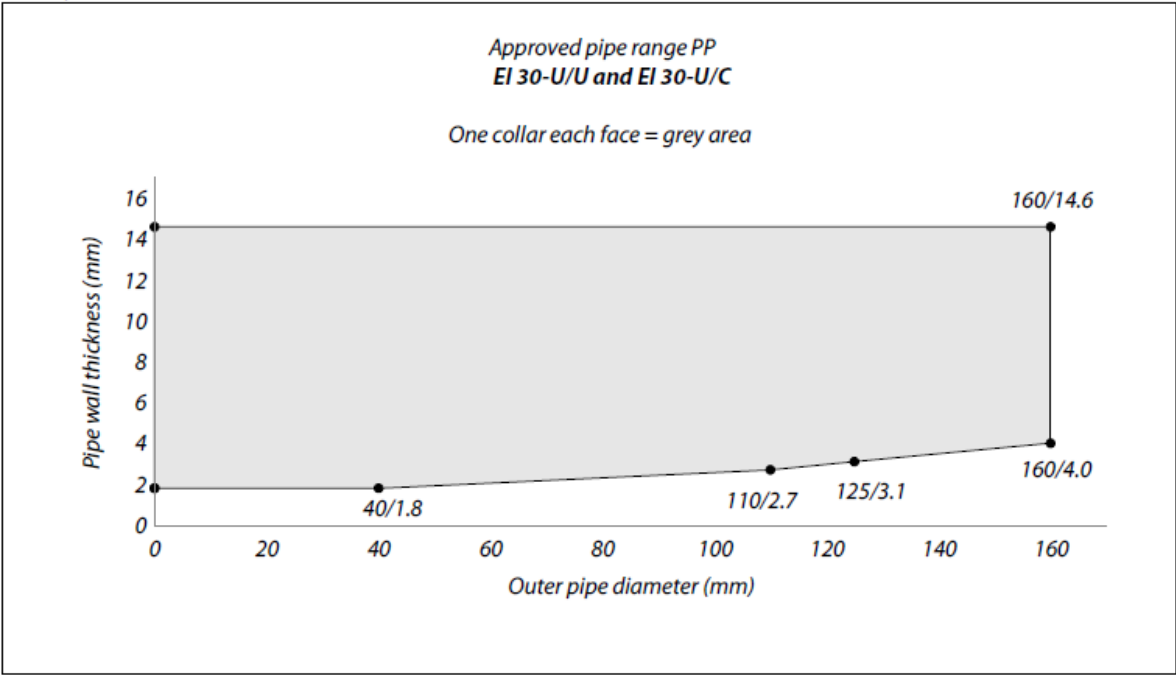
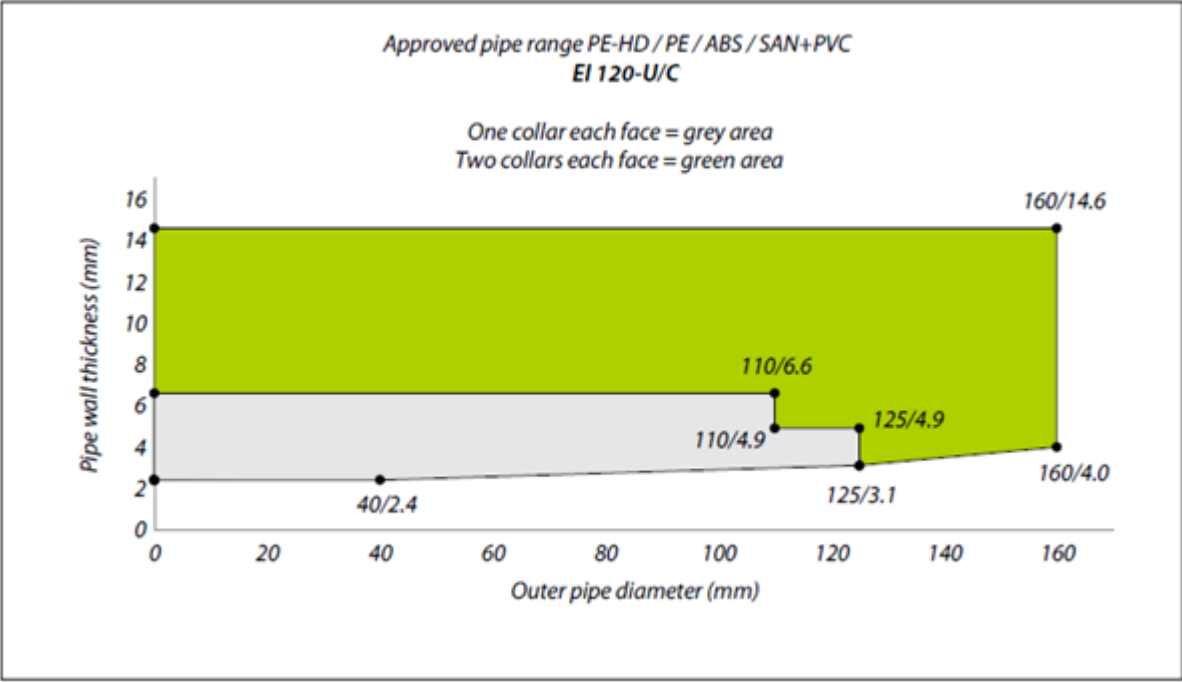

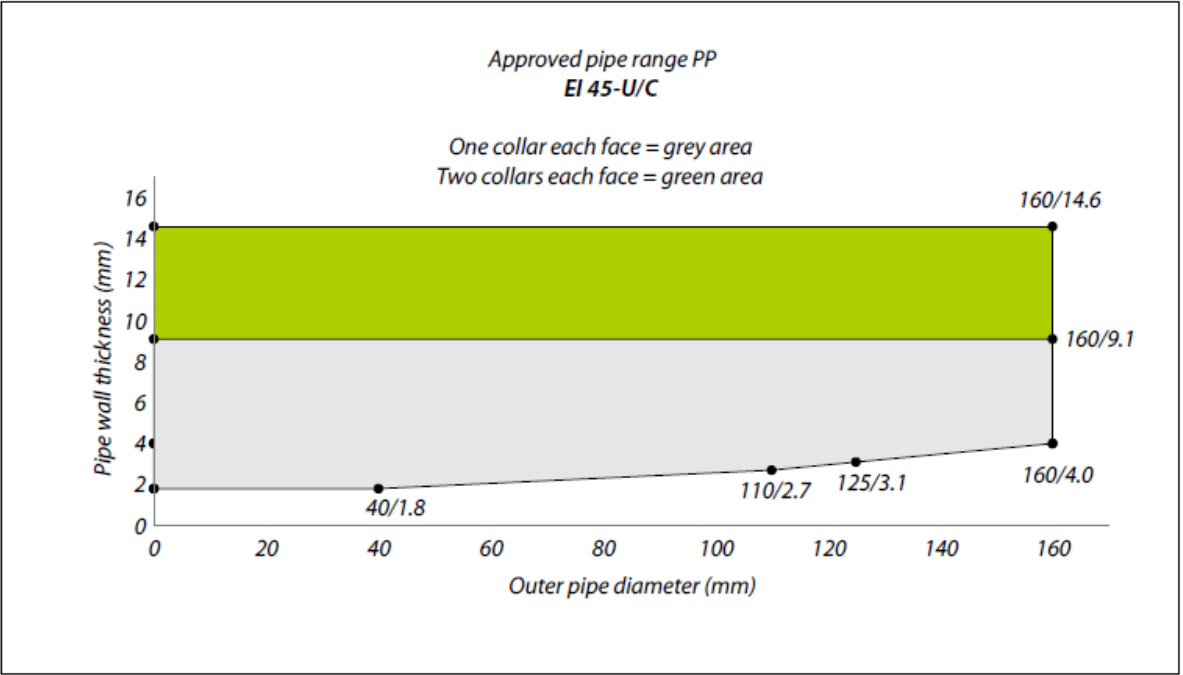
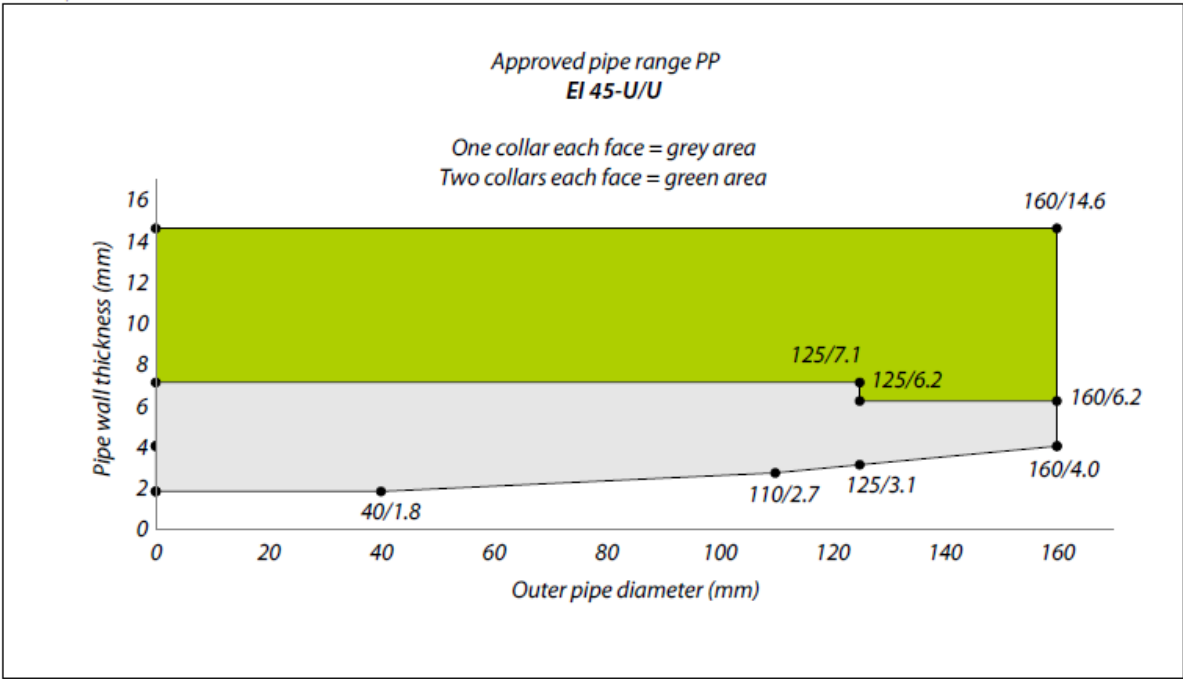

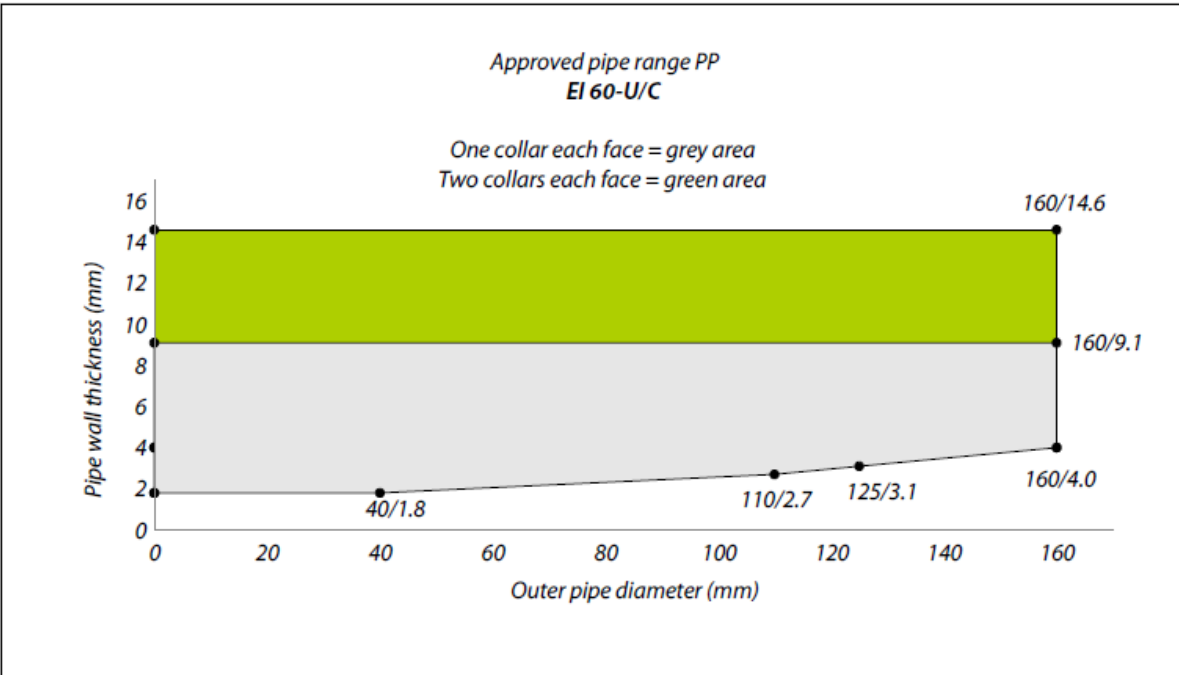
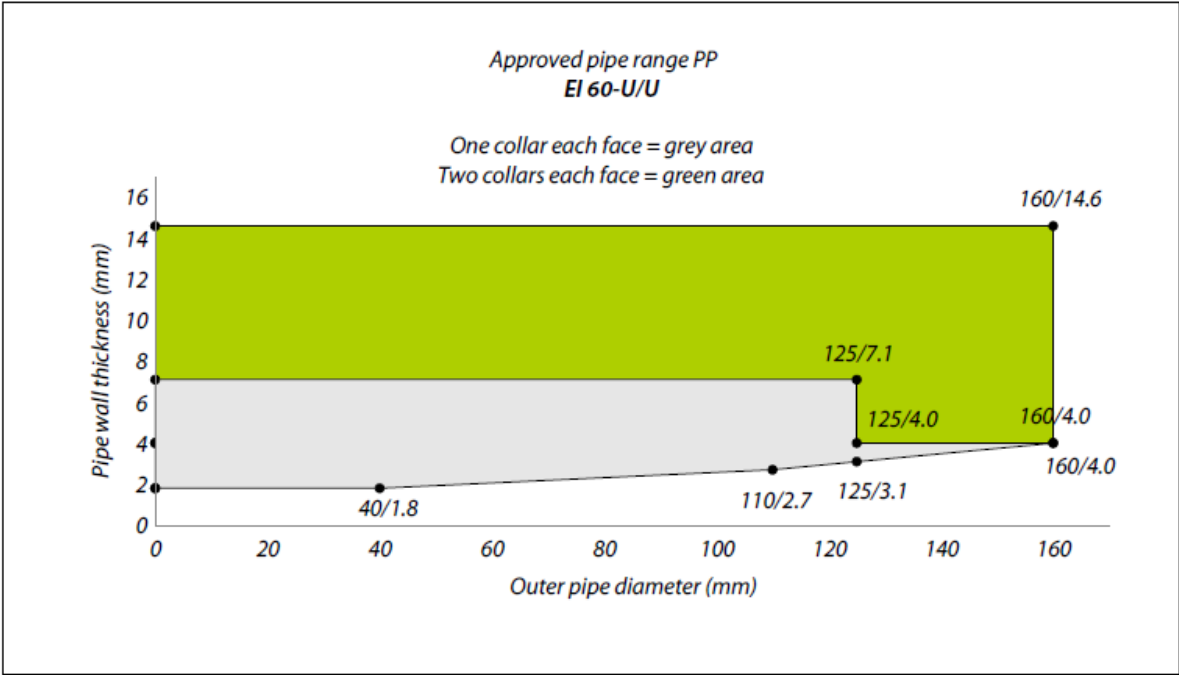

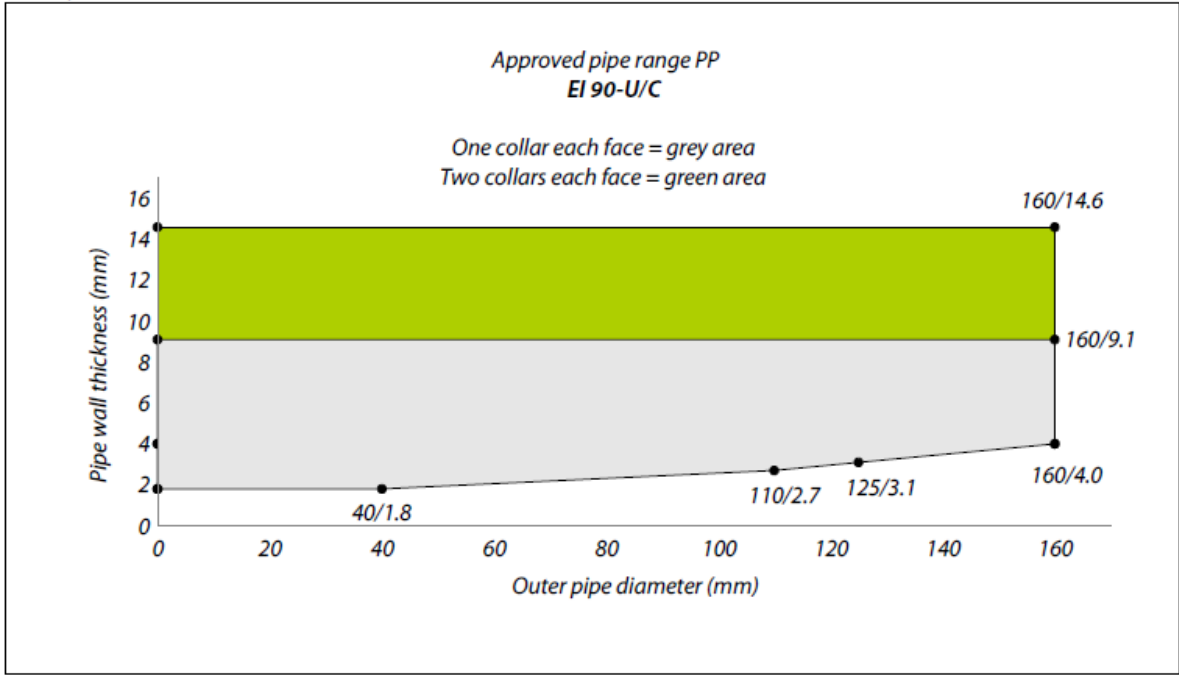
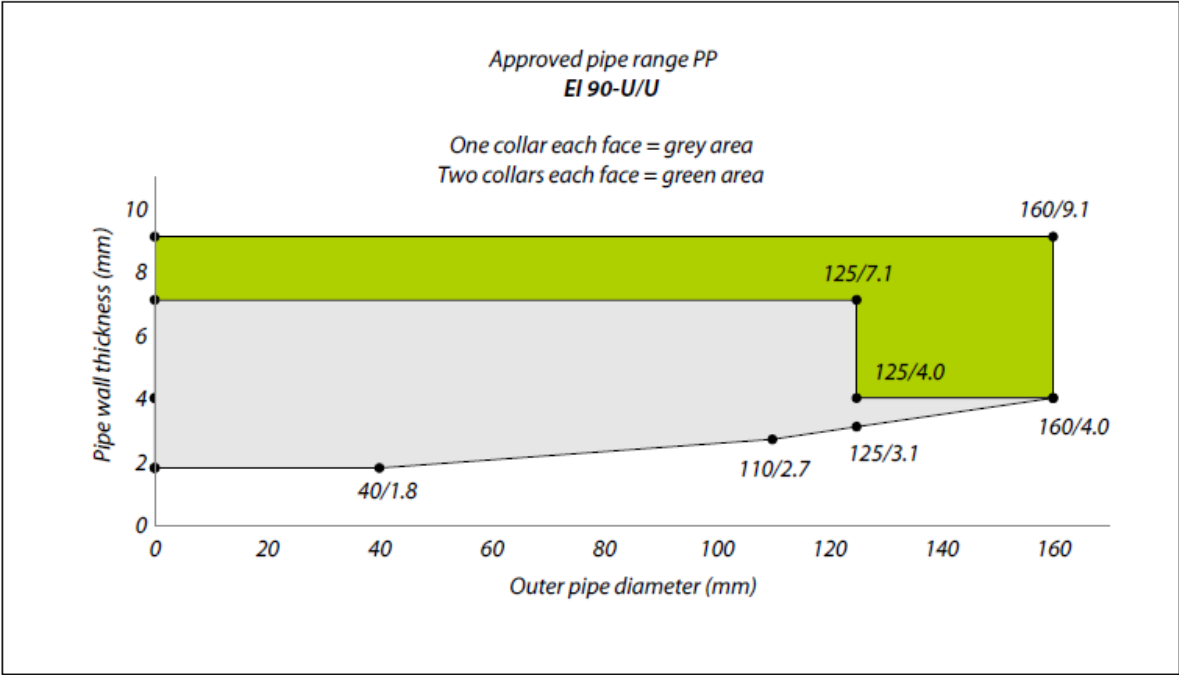

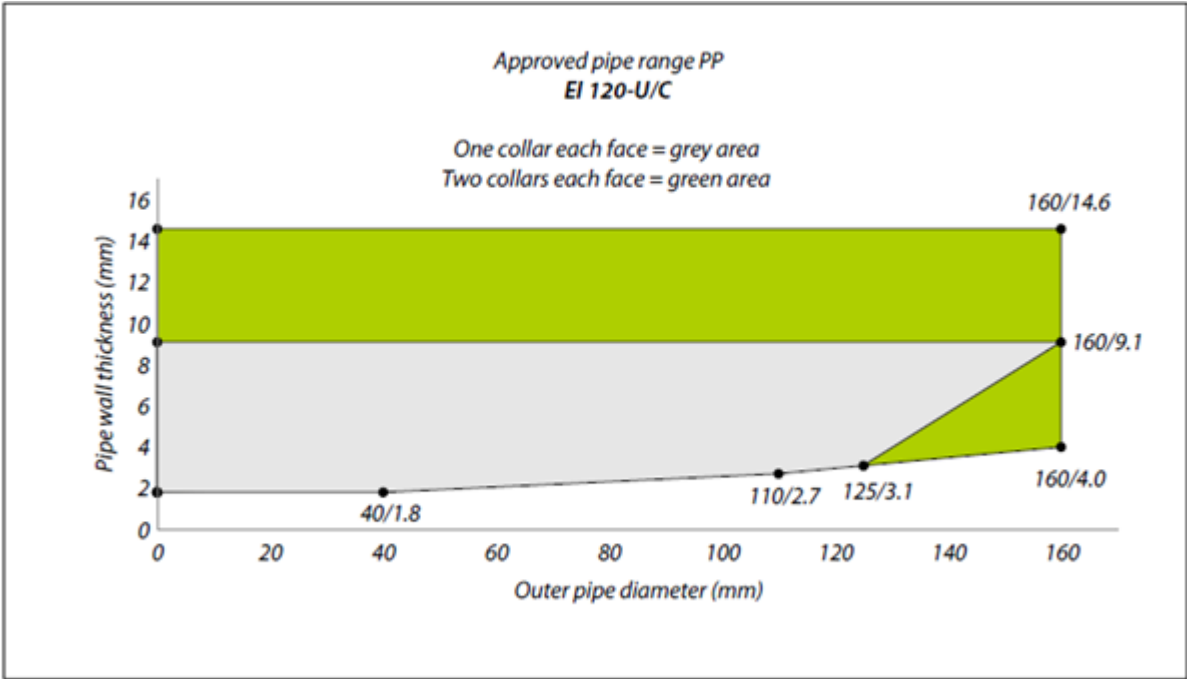
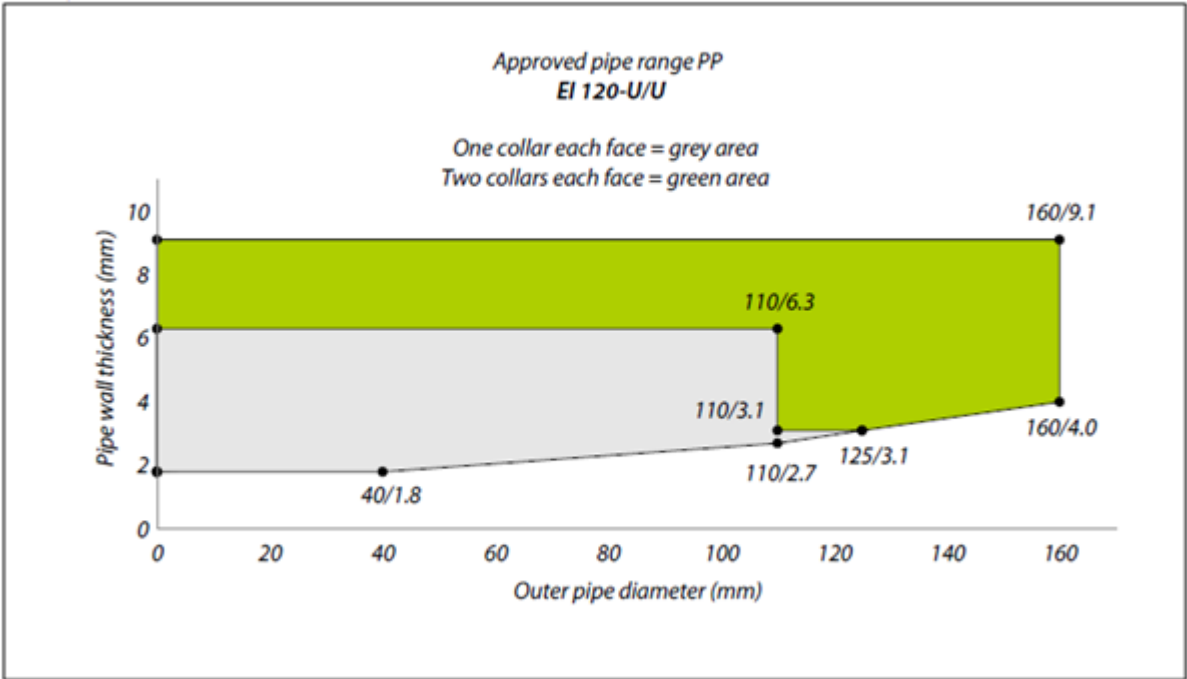

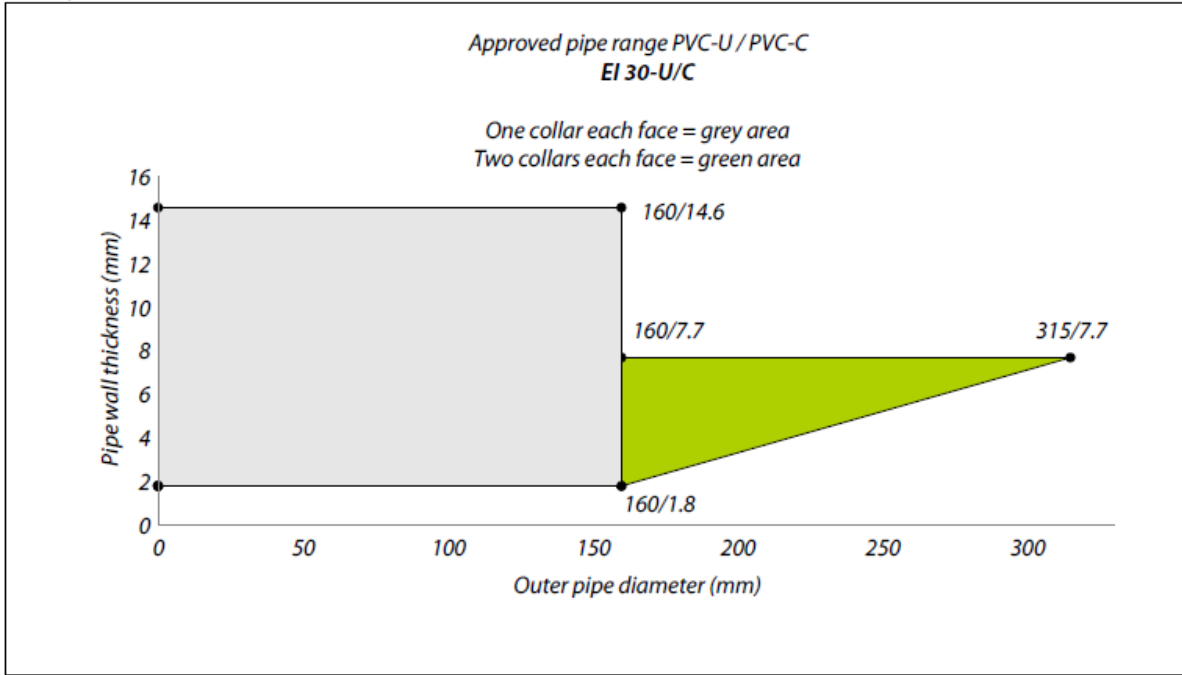
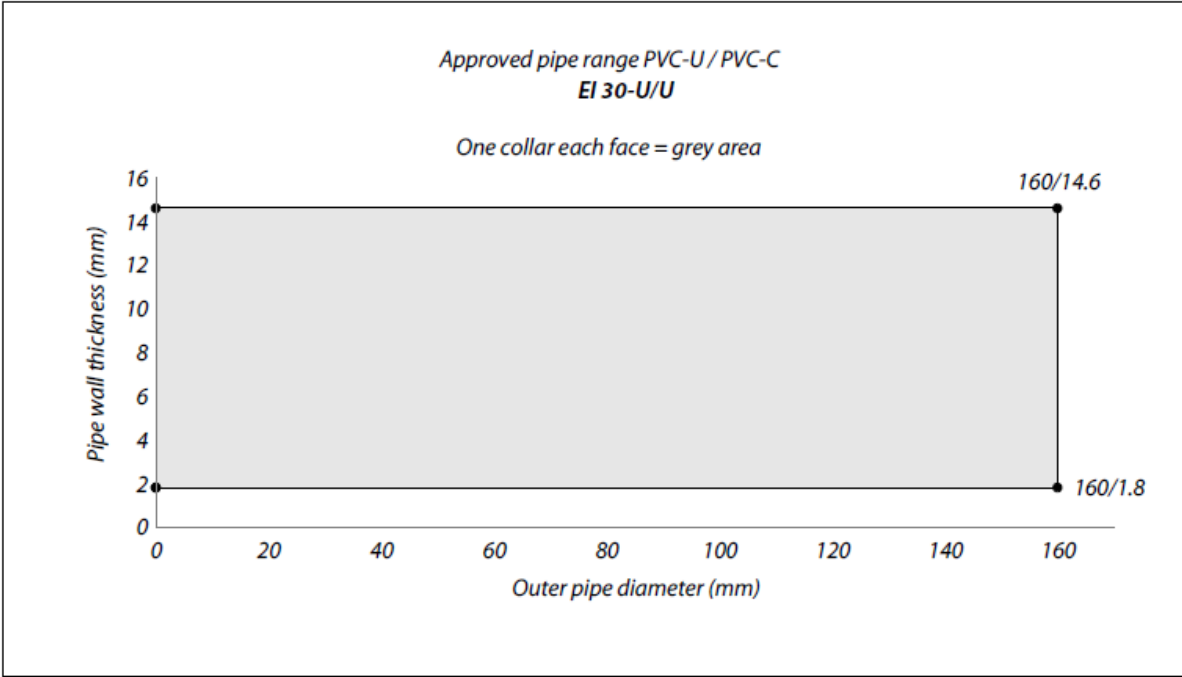

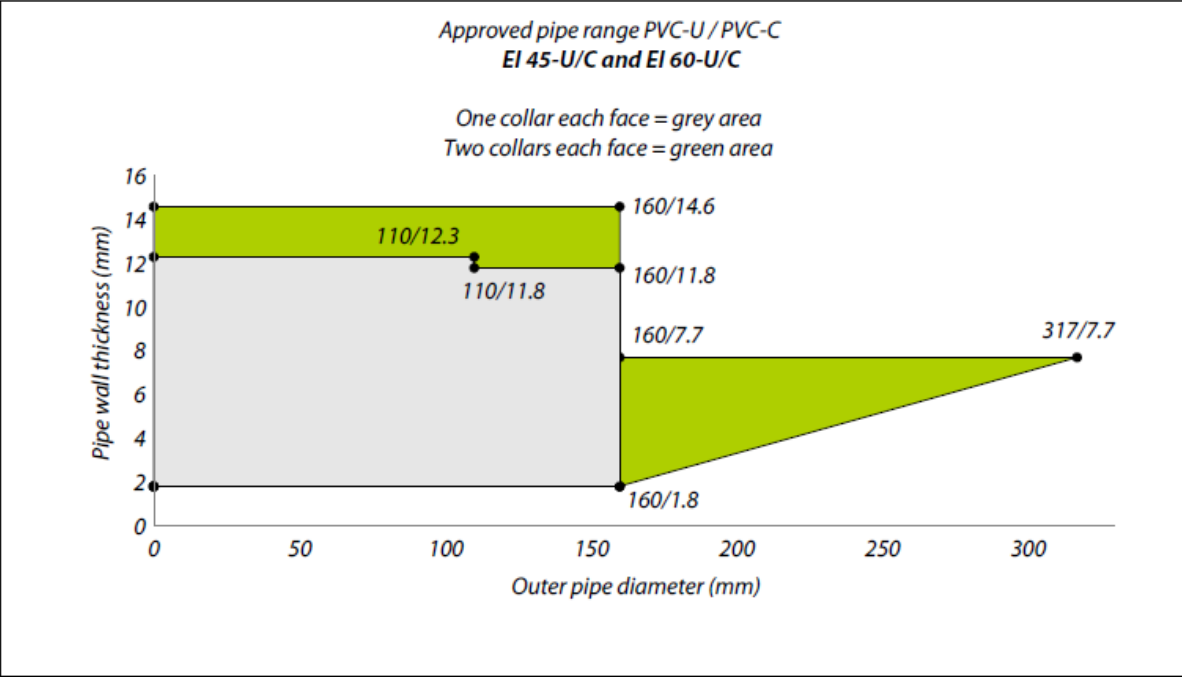
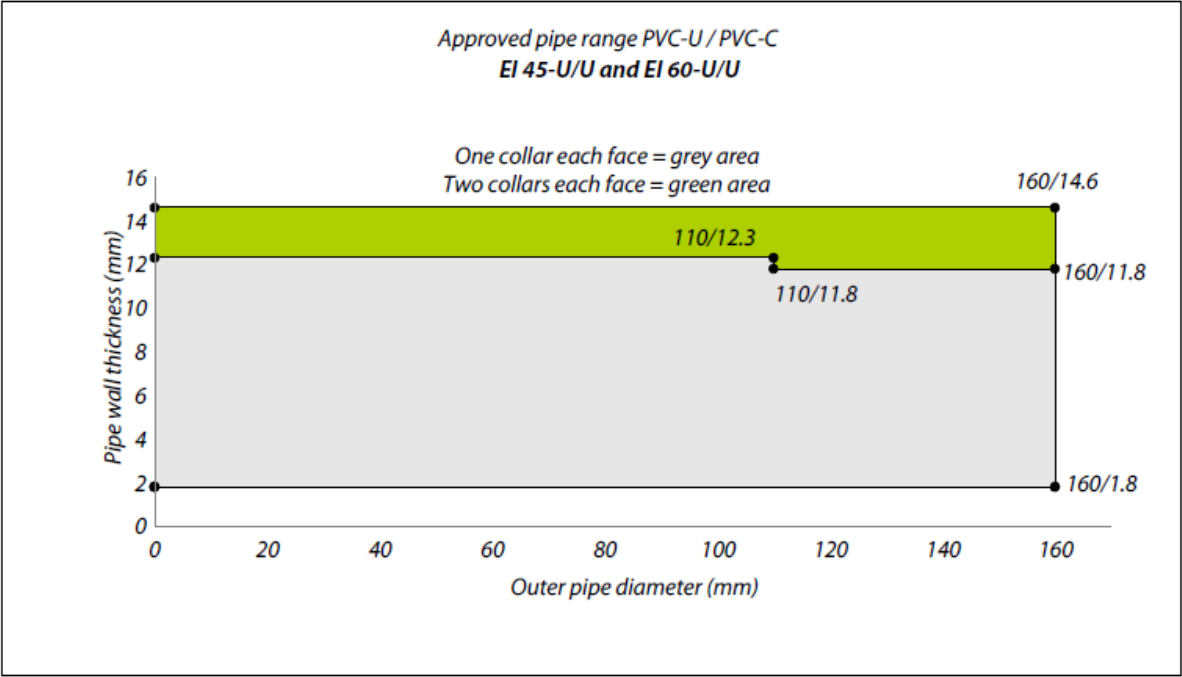

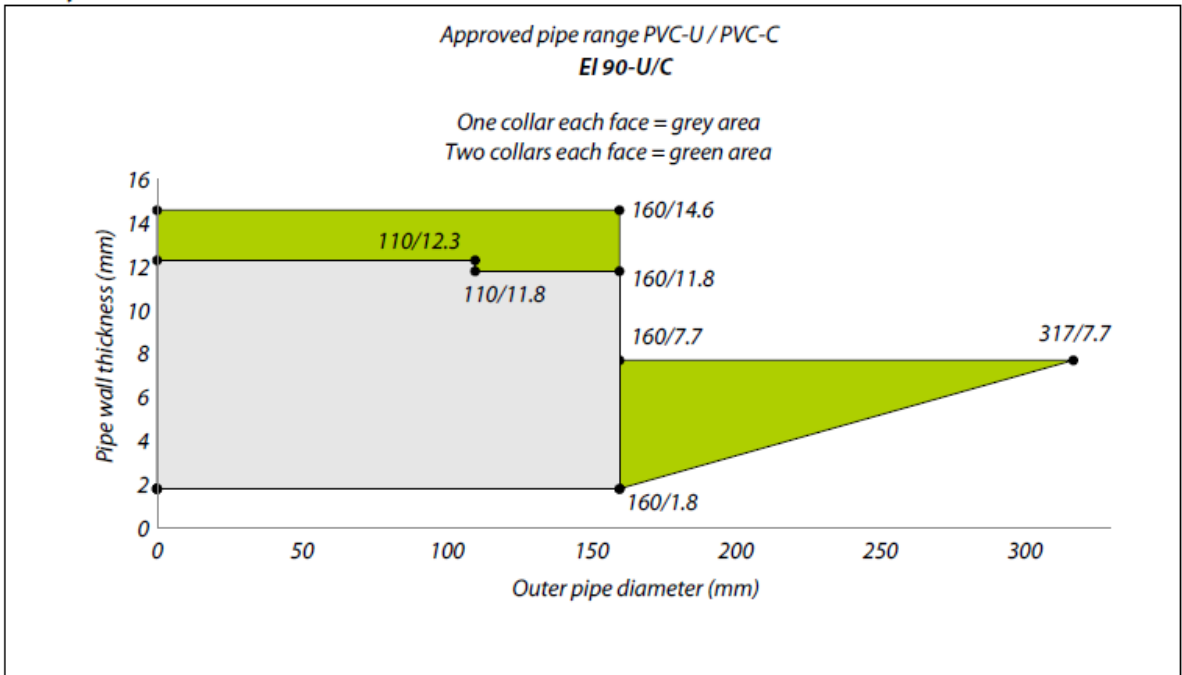
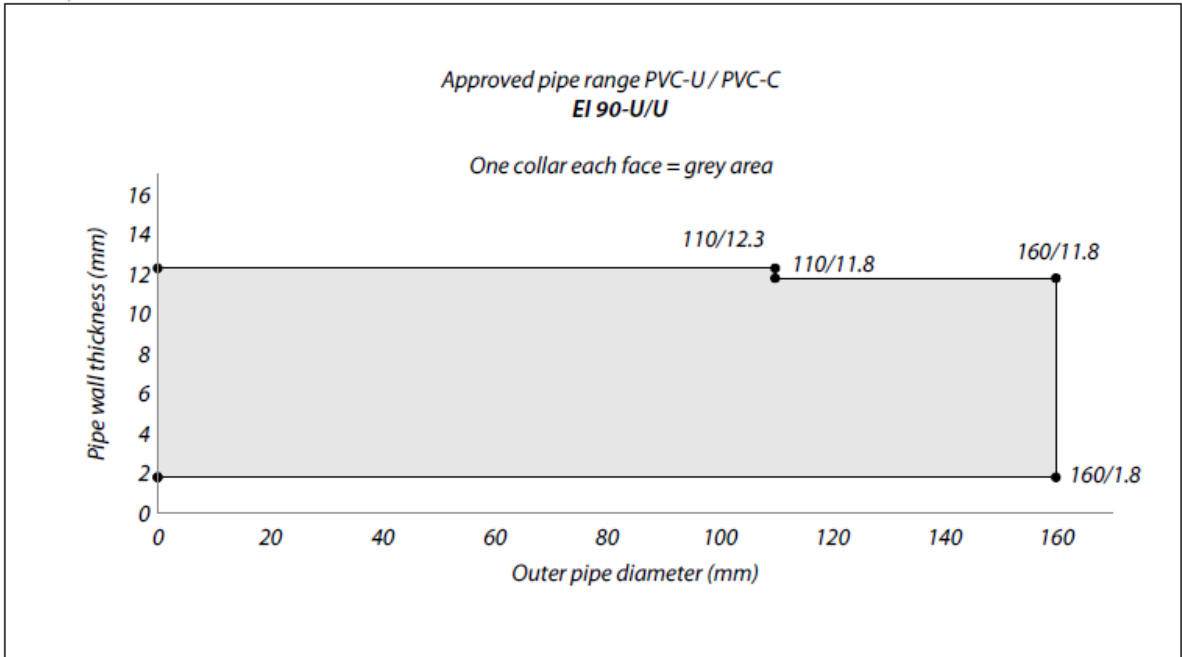

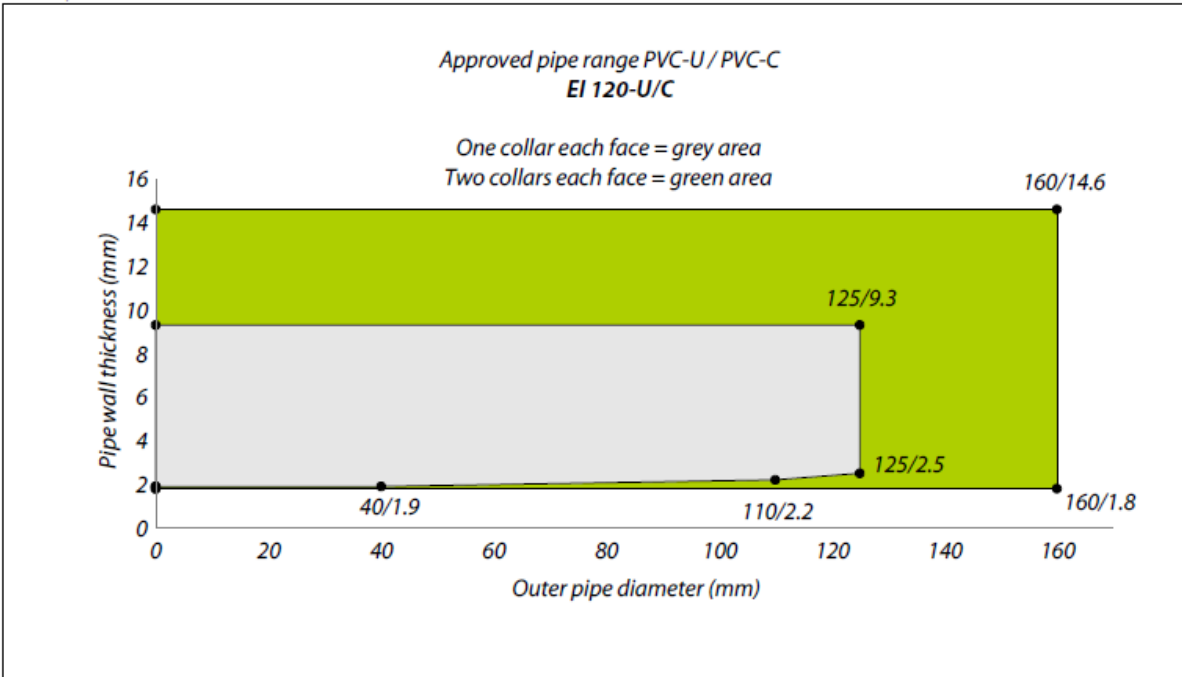
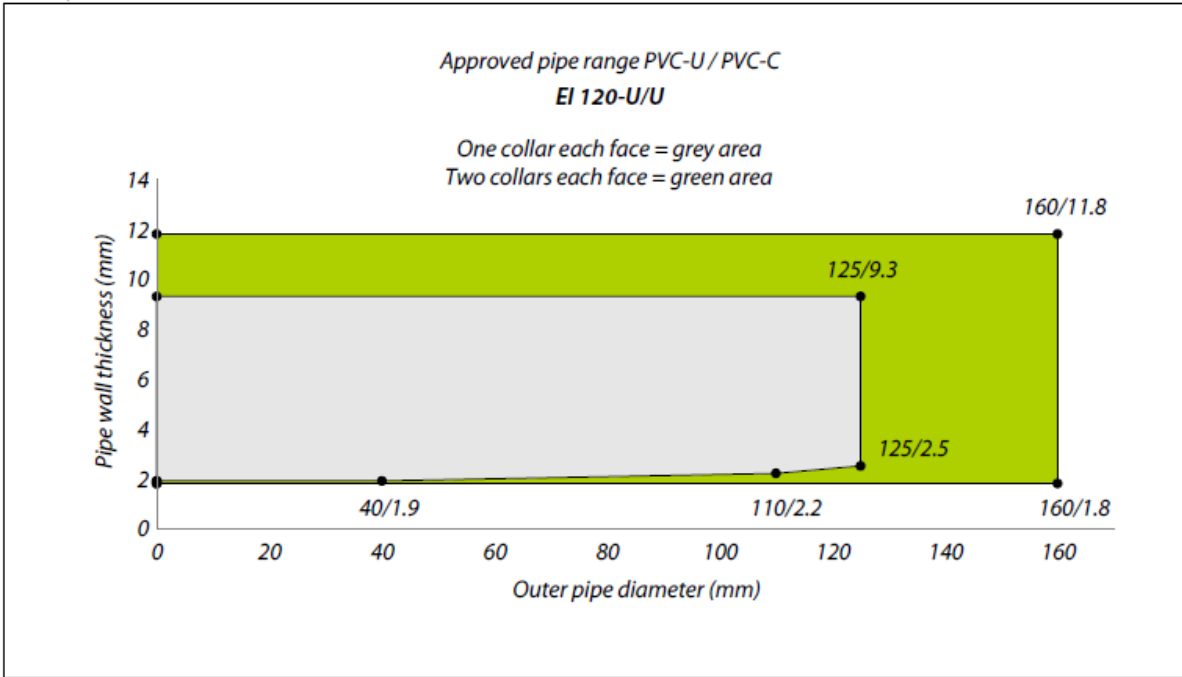

A.1.1.2 Plastic pipes fitted at angles 45°-90° to the wall, with one or two Mulcol® Multicollar Slim pipe collars to both sides of the wall.

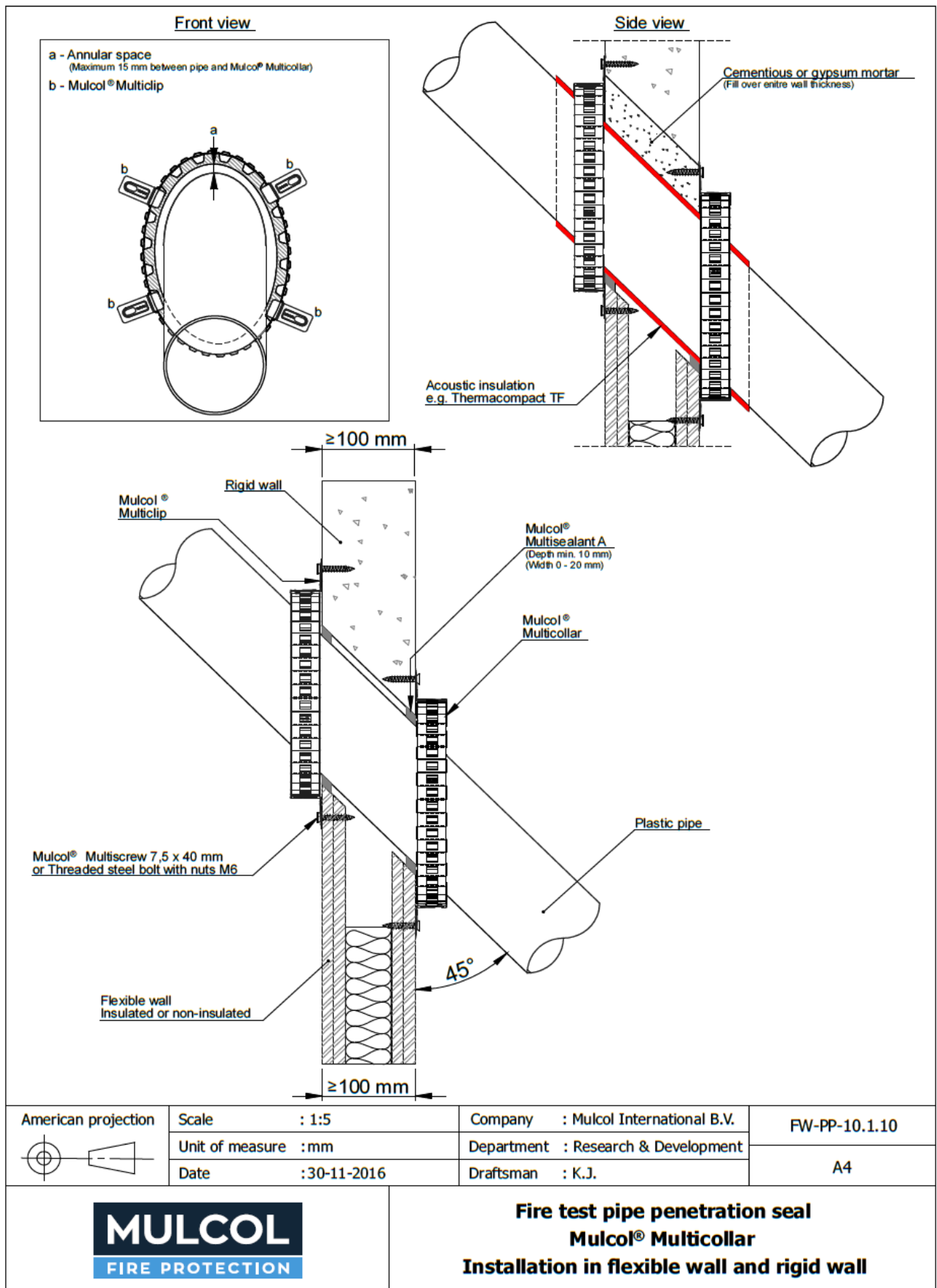

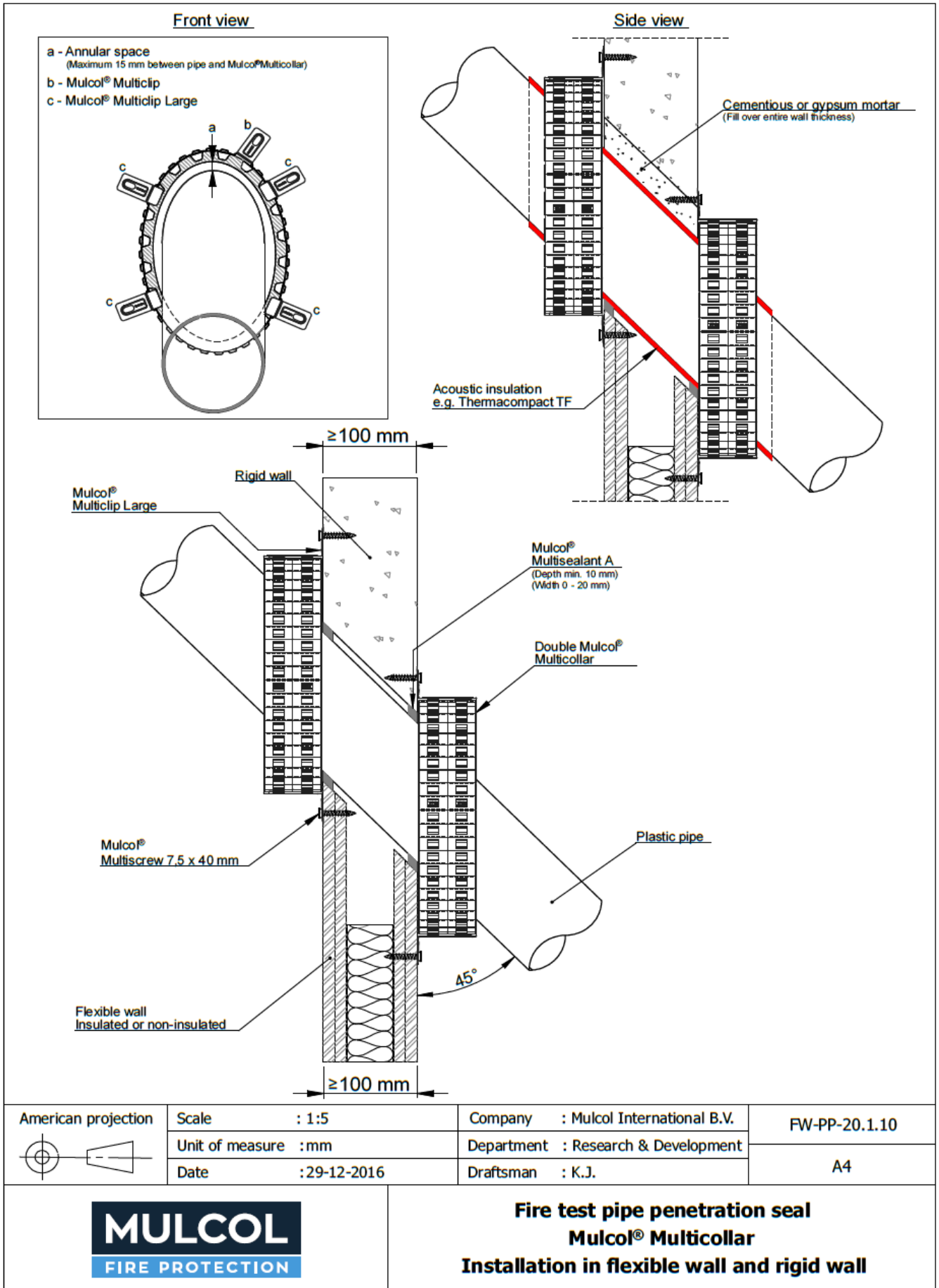

Pipe material [^]	Maximum pipe diameter mm	Pipe wall thickness mm	No. of collars per face	Classification*
PE-HD / PE / ABS / SAN+PVC	110	2.7	one	EI 60 U/C
		3.4-10.0	two	EI 120 U/C
PP	110	2.7	one	E 60 U/C EI 45 U/C
		3.4	two	EI 120 U/C
		3.4-10.0		EI 60 U/C
PVC-U / PVC-C	110	2.7	one	E 60 U/C EI 45 U/C
	125	2.5		E 45 U/C EI 30 U/C
	110	3.4	two	EI 120 U/C
		3.4-10.0		EI 60 U/C

* U/U pipe end configuration applies to U/C, C/U and C/C also

[^] Pipes may optionally be fitted with up to 4 mm thick sound decoupling insulation, min. 50 mm long (LS/CS/LI/CI)

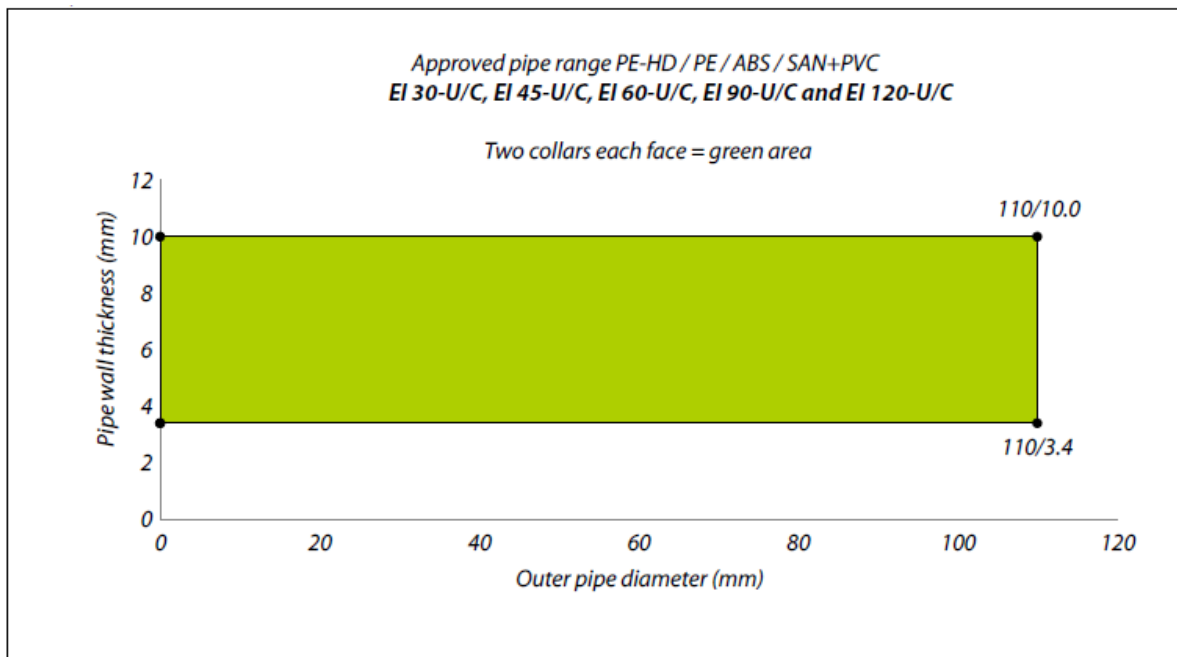

Approved pipe range PP
EI 30-U/C, EI 45-U/C and EI 60-U/C

Two collars each face = green area

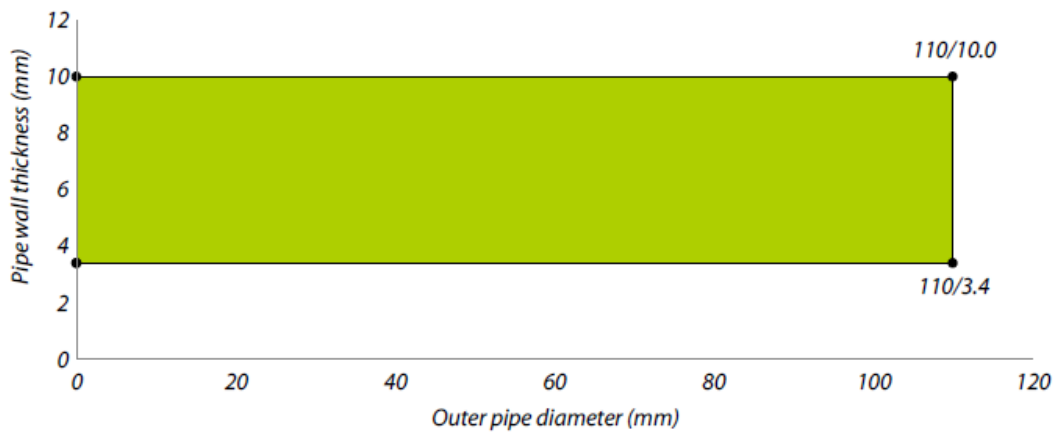

Approved pipe range PVC-U / PVC-C
EI 30-U/C, EI 45-U/C and EI 60-U/C

Two collars each face = green area

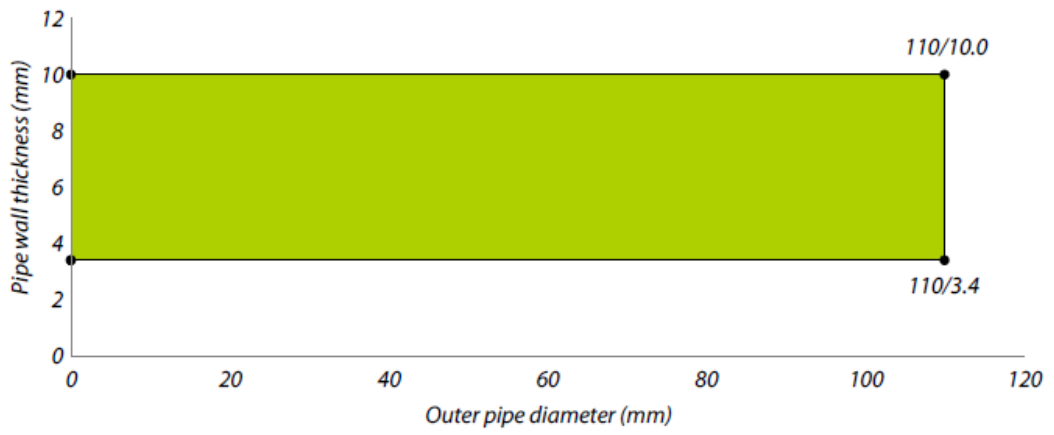

A.1.1.3 Plastic pipes, perpendicular to the wall, in Mulcol® Multimastic FB1 coated board seals, with one Mulcol® Multicollar Slim pipe collars to both sides of the seal

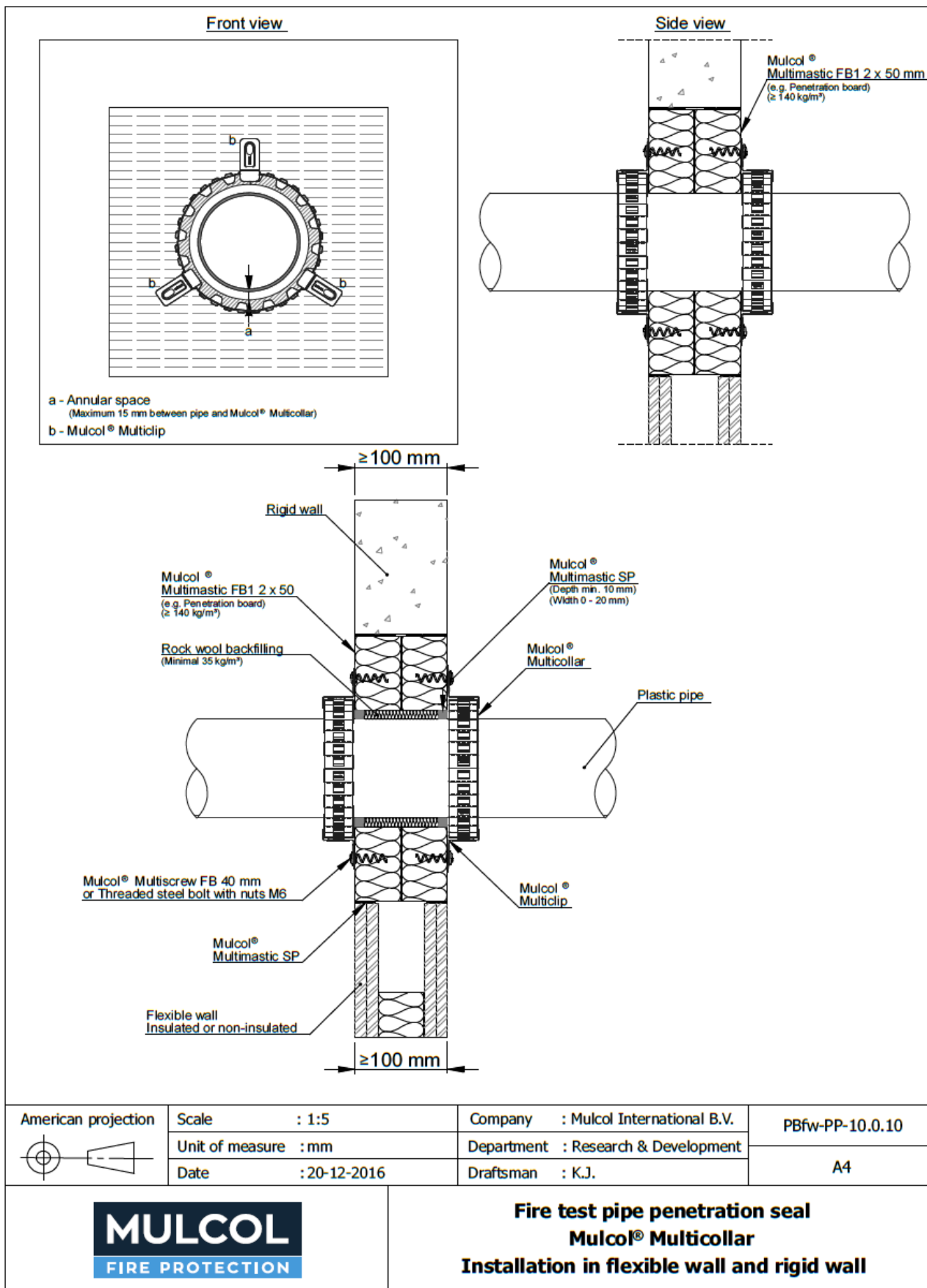

Pipe material	Maximum pipe diameter mm	Pipe wall thickness mm	No. of collars per face	Classification*
PE-HD / PE / ABS / SAN+PVC	110	2.7	one	EI 120 U/U
PVC-U / PVC-C				
PP				

* U/U pipe end configuration applies to U/C, C/U and C/C also

A.1.1.4 Plastic pipes insulated with AF/Armaflex made out of flexible elastomeric EPDM rubber foam with a min. reaction to fire class BL-s3, d0 or B-s3 or, d0 (to EN 13501-1), perpendicular to the wall, with two Mulcol® Multicollar Slim pipe collars to both sides of the wall.

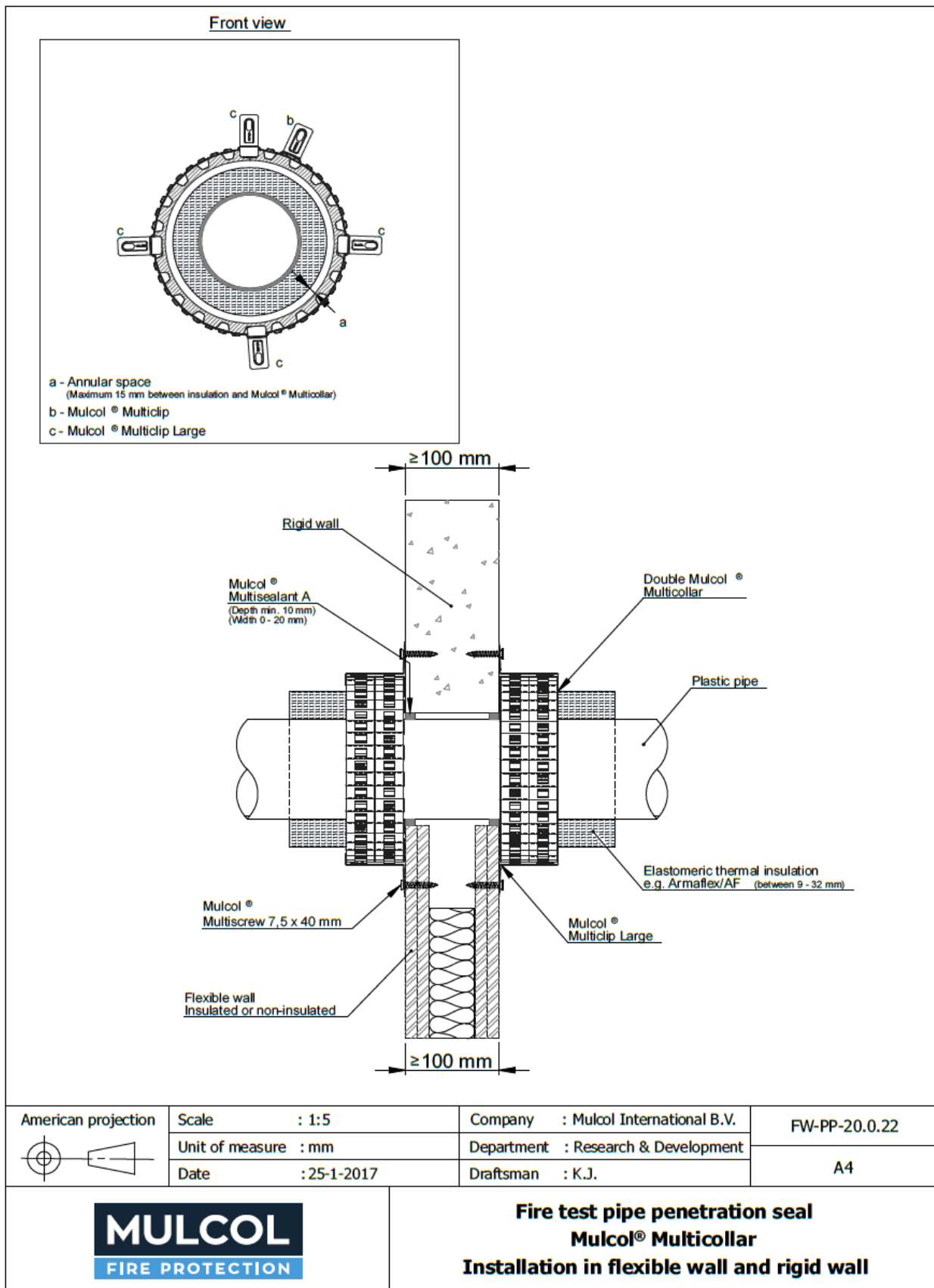

Pipe material[^]	Maximum pipe diameter mm	Pipe wall thickness mm	Insulation LI/CI thickness/length mm	No. of collars per face	Classification*
PVC-U / PVC-C	110	3.2	9-32 / 450 (min.)	Two	EI 120 U/U

* U/U pipe end configuration applies to U/C, C/U and C/C also

A.1.1.5 Plastic pipes insulated with AF/Armaflex made out of flexible elastomeric EPDM rubber foam with a min. reaction to fire class BL-s3, d0 or B-s3 or, d0 (to EN 13501-1), perpendicular to the wall, with two Mulcol® Multicollar Slim pipe collars to both sides of the wall.

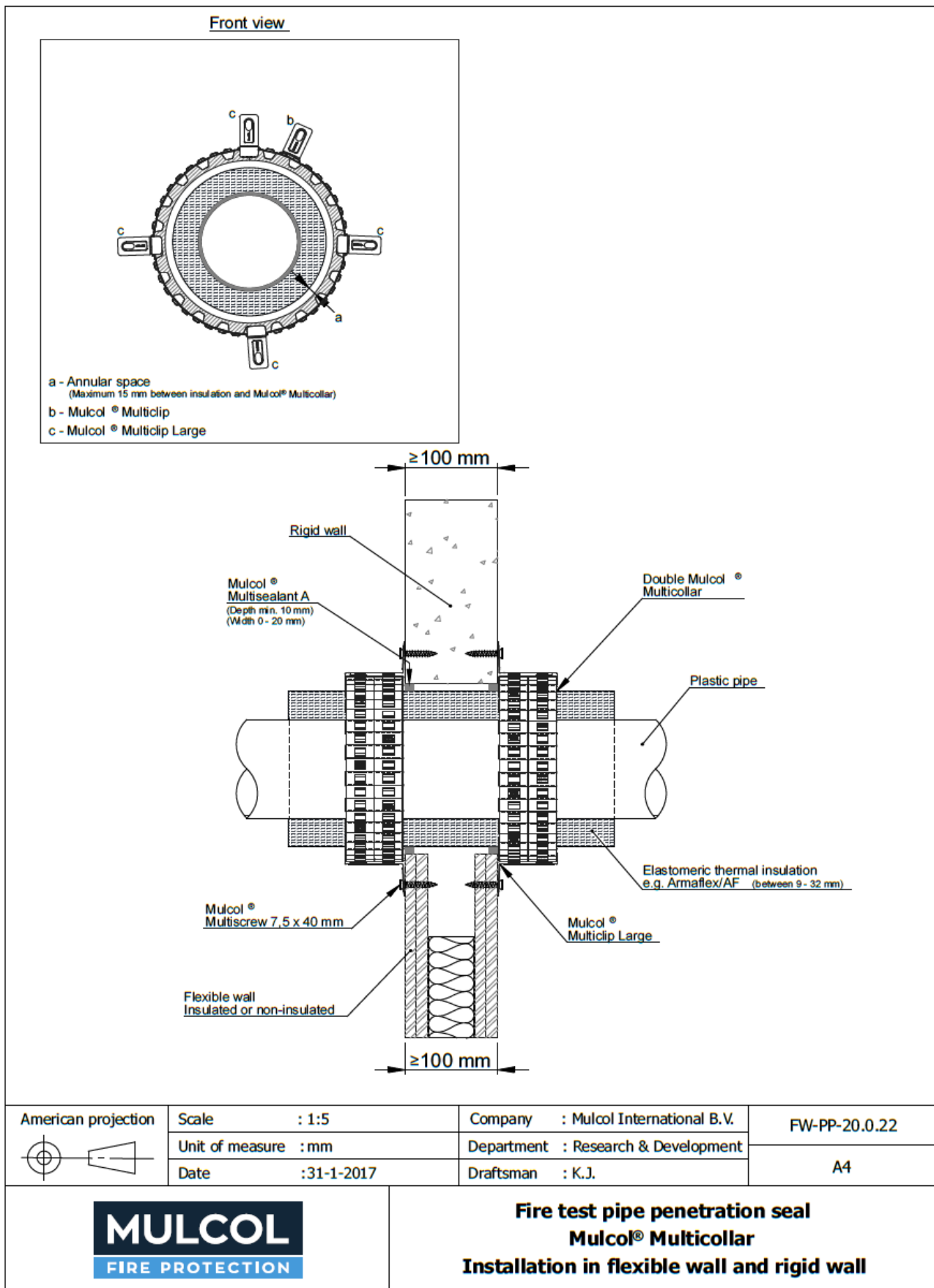

Pipe material [^]	Maximum pipe diameter mm	Pipe wall thickness mm	Insulation LS/CS/LI/CI thickness/ length mm	No. of collars per face	Classification*
PVC-U / PVC-C	110	3.2	9-32 / 450 (min.)	Two	E 120 U/U EI 90 U/U

* U/U pipe end configuration applies to U/C, C/U and C/C also

A.1.2 Plastic pipes with sockets

A.1.2.1 Plastic pipes with (electrofusion) pipe coupling, perpendicular to the wall, with one Mulcol® Multicollar Slim pipe collars to both sides of the wall

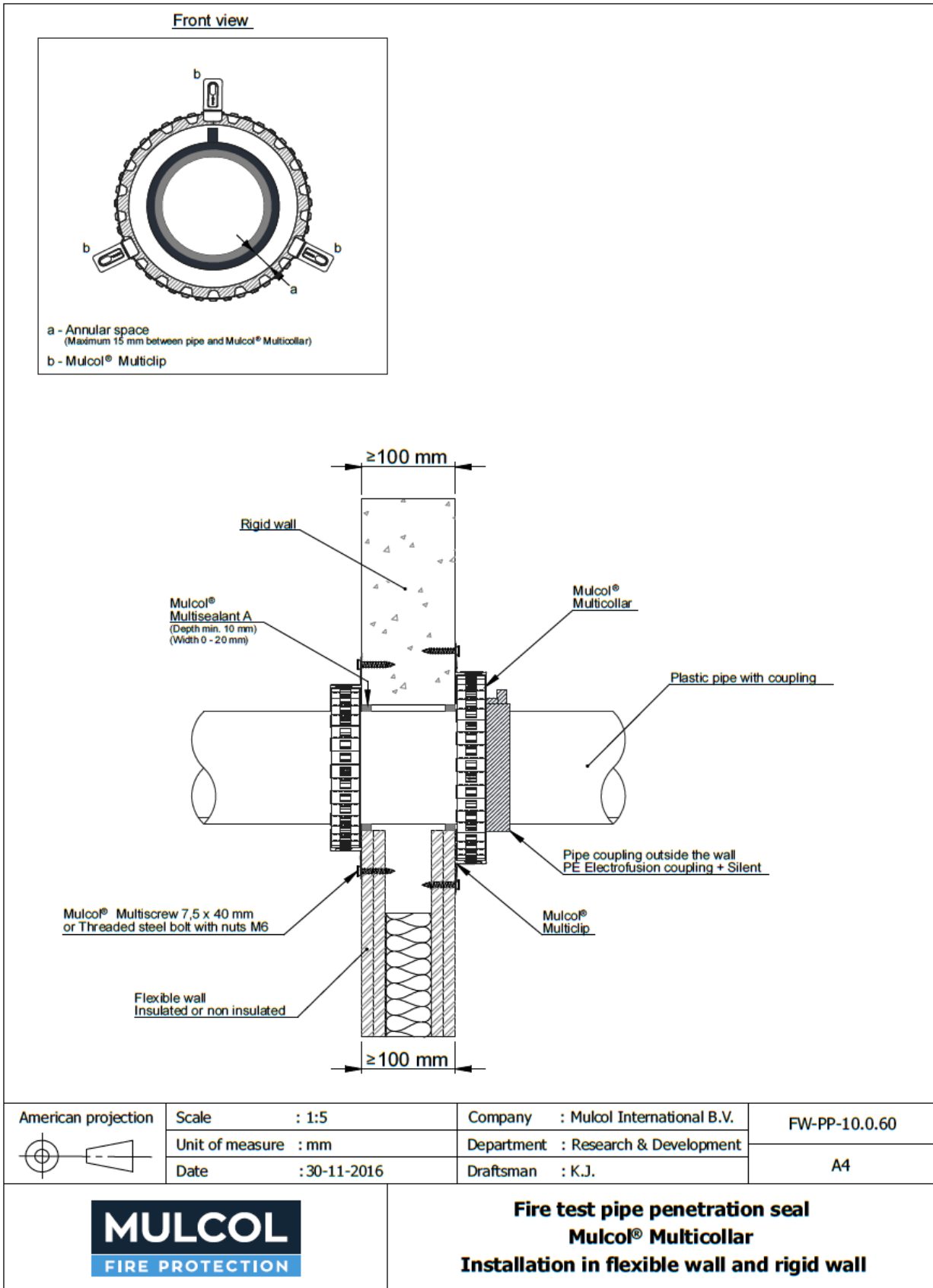

Pipe material	Maximum pipe diameter mm	Pipe wall thickness mm	No. of collars per face	Classification*
PE-HD / PE / ABS / SAN+PVC	110	4.3-7.4	one	EI 120 U/C
	125	7.4		E 90 U/C EI 60 U/C

* U/C pipe end configuration applies to C/C also

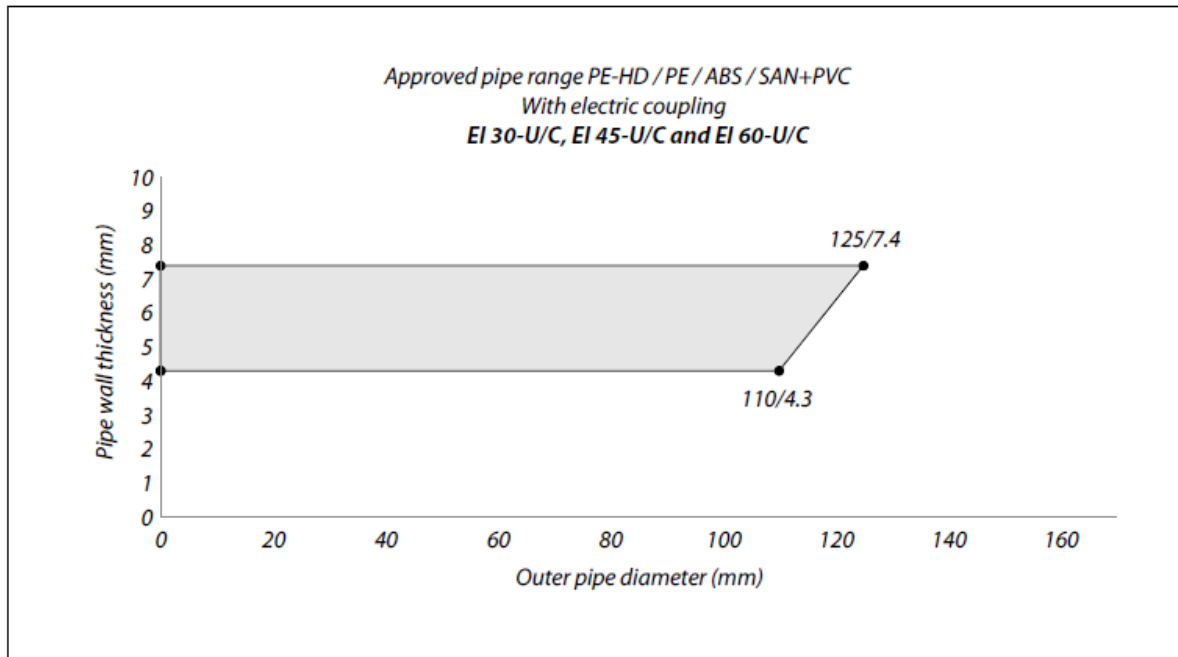

A.1.3 Plastic pipes pipes with elbows

A.1.3.1 Plastic pipes with an elbow, perpendicular to the wall, with one Mulcol® Multicollar Slim pipe collars to both sides of the wall

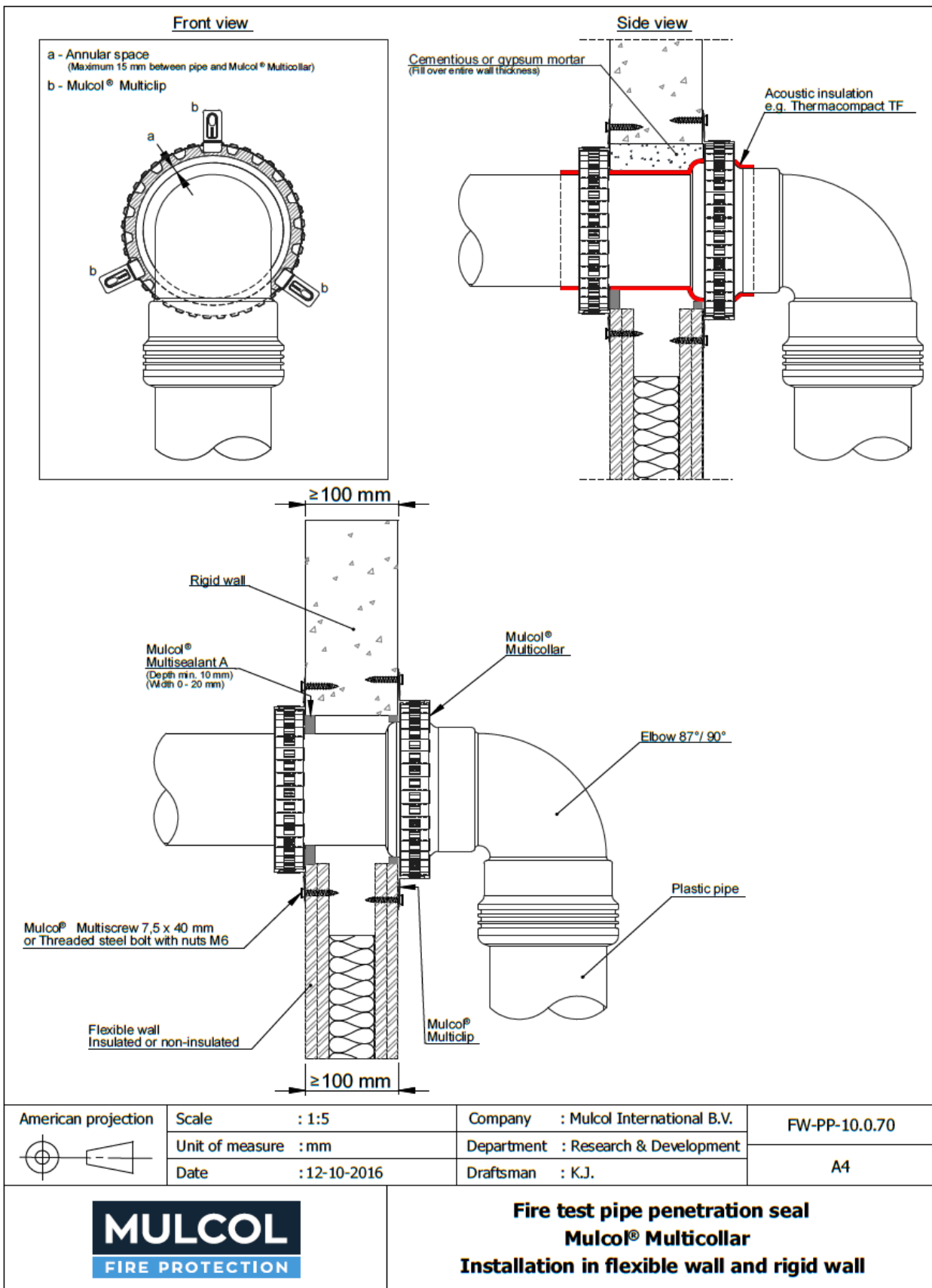

Pipe material [^]	Maximum pipe diameter mm	Pipe wall thickness mm	No. of collars per face	Classification*
PP/ Elbow	125	3.1	one	EI 90 U/C
PVC-U, PVC-C / elbow		2.5		EI 90 U/U

* U/U pipe end configuration applies to U/C, C/U and C/C also

[^] Pipes may optionally be fitted with up to 4 mm thick sound decoupling insulation, min. 50 mm long (LS/CS/LI/CI)

A.1.3.2 Plastic pipes with an elbow, perpendicular to the wall, with one Mulcol® Multicollar Slim pipe collar to both sides of the wall in an 'U' shape.

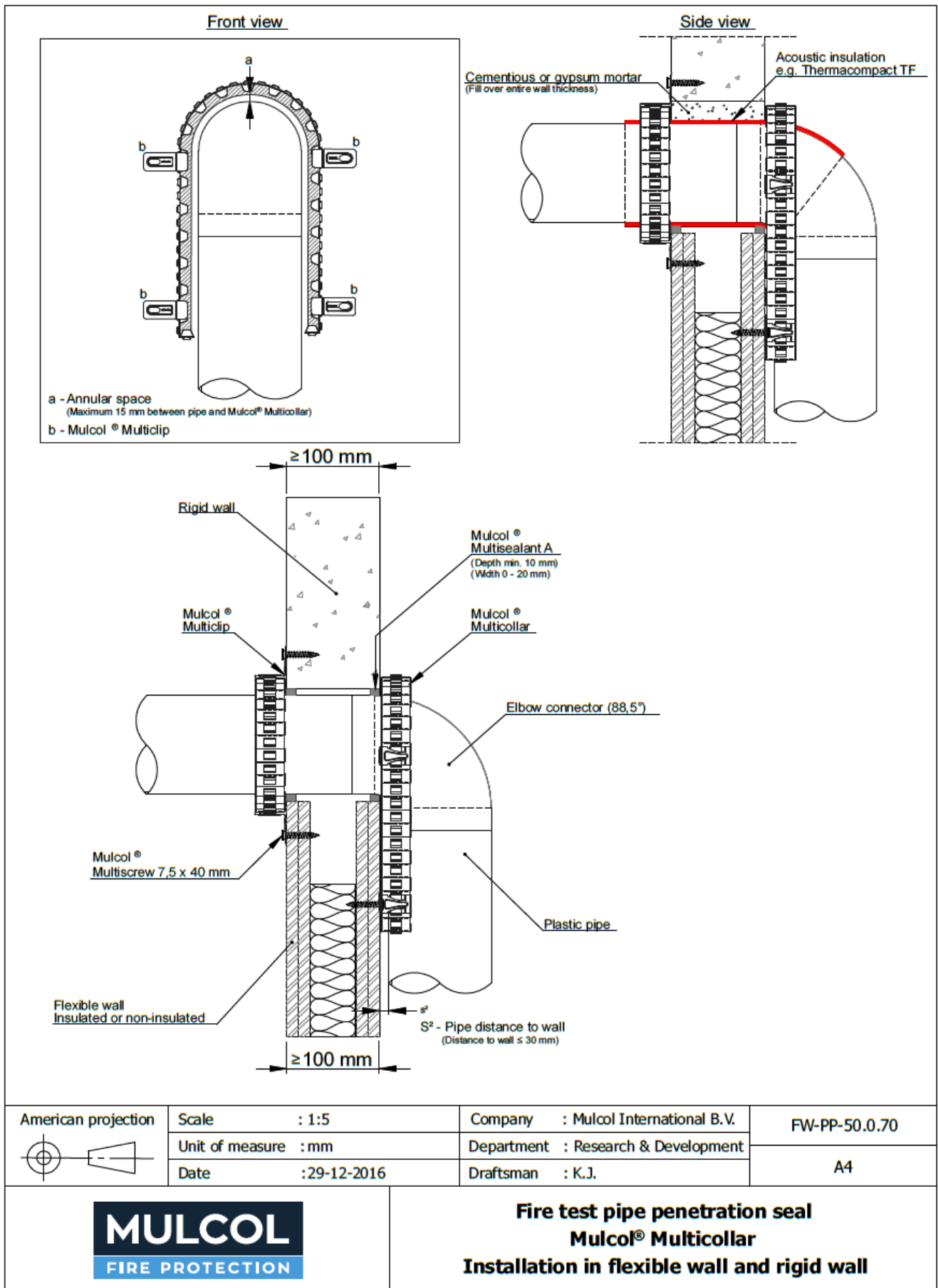

Pipe material [^]	Maximum pipe diameter mm	Pipe wall thickness mm	No. of collars per face	Classification*
PE-HD / PE / ABS / SAN+PVC	110	3.4	one	EI 120 U/C
PP				
PVC-U / PVC-C				

* U/C pipe end configuration applies to C/C also

[^] Pipes may optionally be fitted with up to 4 mm thick sound decoupling insulation, min. 50 mm long (LS/CS/LI/CI)

A.1.4 Plastic pipes pipes with zero distance to the floor

A.1.4.1 Plastic pipes, perpendicular to the wall, in wall corner, with one Mulcol® Multicollar Slim pipe collars to both sides of the wall

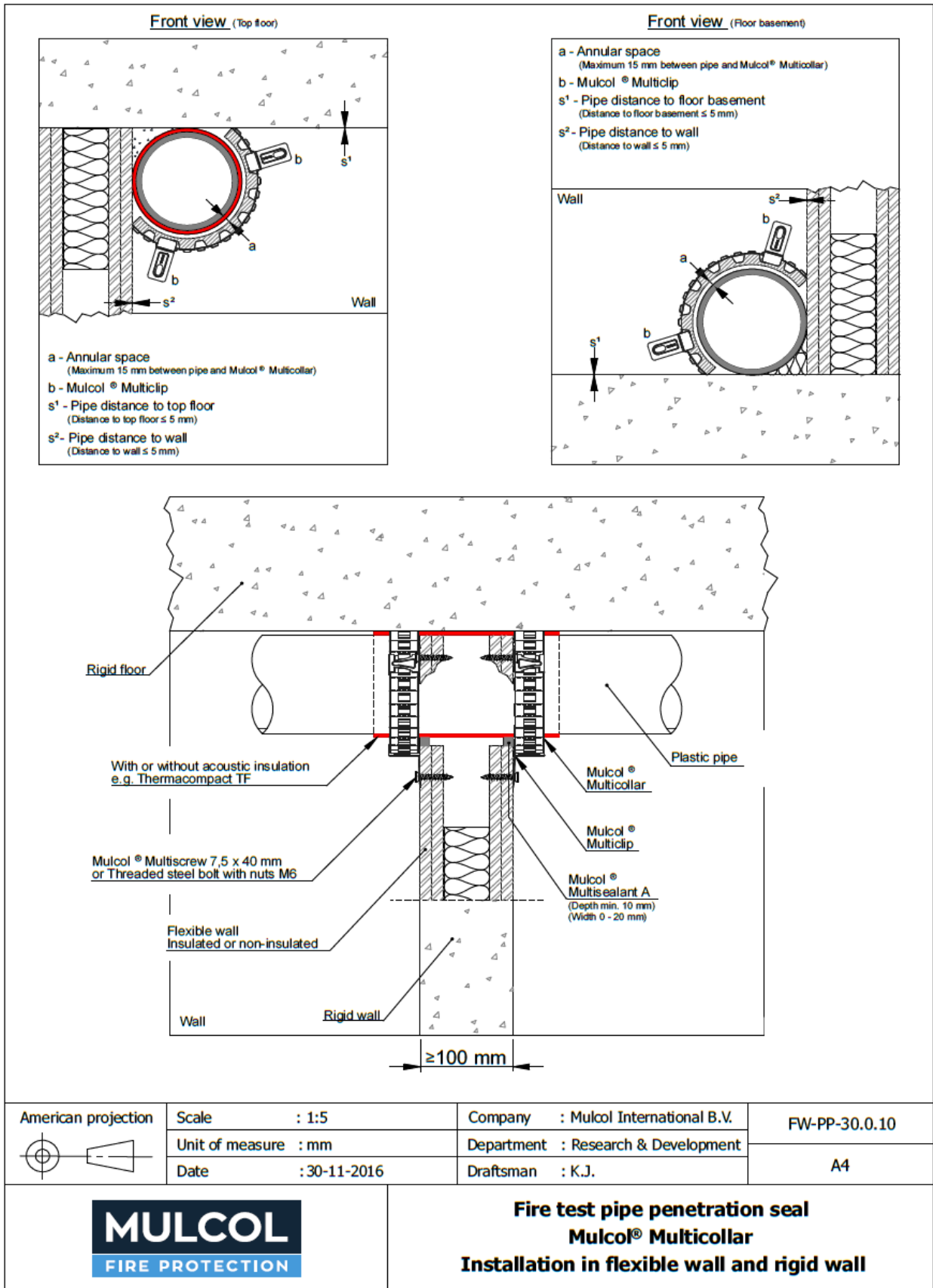

Pipe material [^]	Maximum pipe	Pipe wall	No. of collars	Location	Classification*
----------------------------	--------------	-----------	----------------	----------	-----------------

	diameter mm	thickness mm	per face		
PVC-U / PVC-C	110	2.2	one	Bottom corner	E 120 U/U EI 90 U/U
		3.2		Top corner	

* U/U pipe end configuration applies to U/C, C/U and C/C also

^ Pipes may optionally be fitted with up to 4 mm thick sound decoupling insulation, min. 50 mm long (LS/CS/LI/CI)

A.1.4.2 Plastic pipes, perpendicular to the wall, with zero distance to the floor, with one Mulcol® Multicollar Slim pipe collars to both sides of the wall.

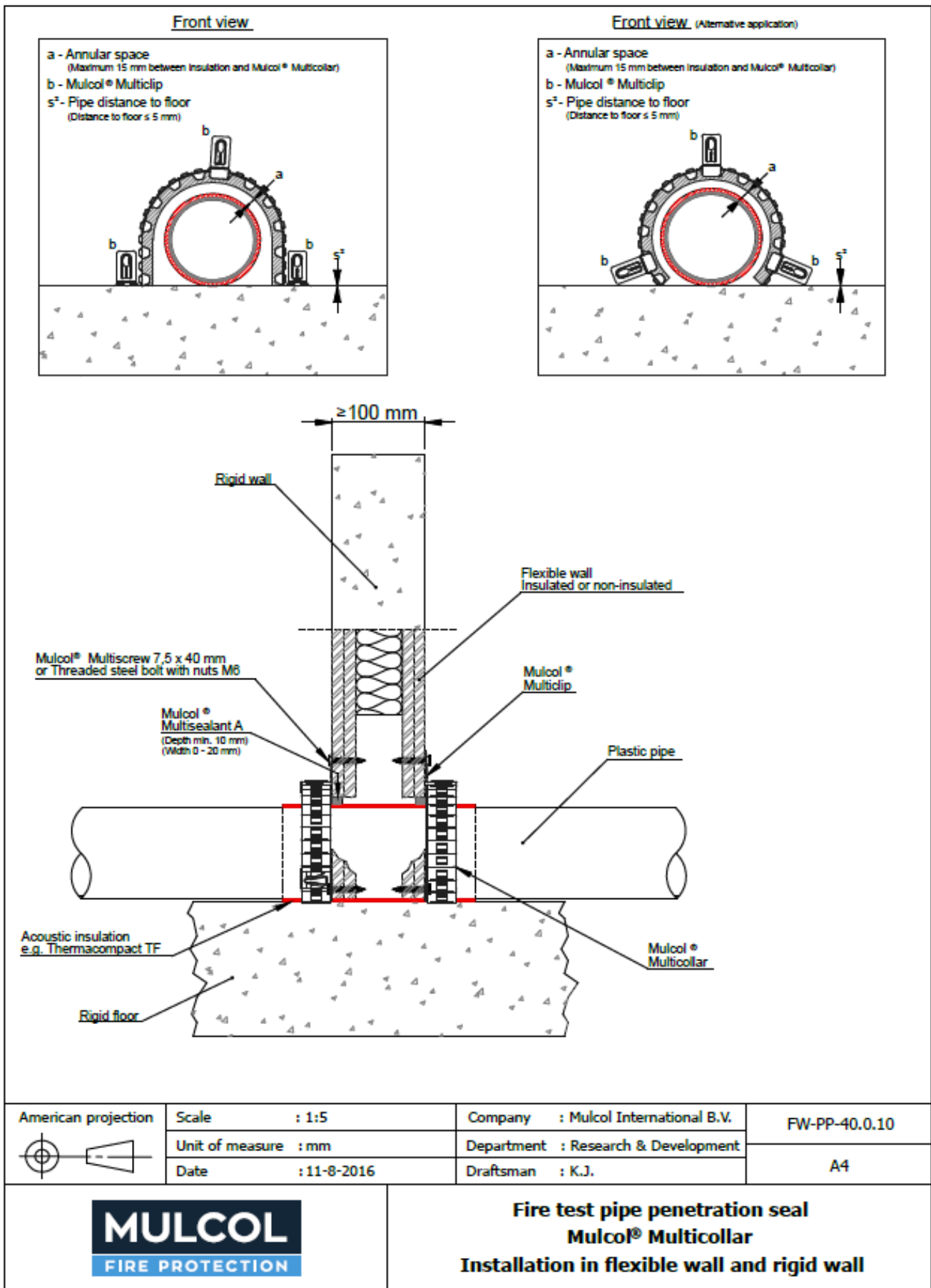

Pipe material [^]	Maximum pipe diameter mm	Pipe wall thickness mm	No. of collars per face	Classification*
PE-HD / PE / ABS / SAN+PVC	90	2.8	one	EI 90 U/U
PVC-U / PVC-C	110	2.2		

* U/U pipe end configuration applies to U/C, C/U and C/C also

[^] Pipes may optionally be fitted with up to 4 mm thick sound decoupling insulation, min. 50 mm long (LS/CS/LI/CI)

A.1.5 Plastic pipes in conduits

A.1.5.1 Plastic pipes in PE conduits with one Mulcol® Multicollar Slim pipe collars to both sides of the wall

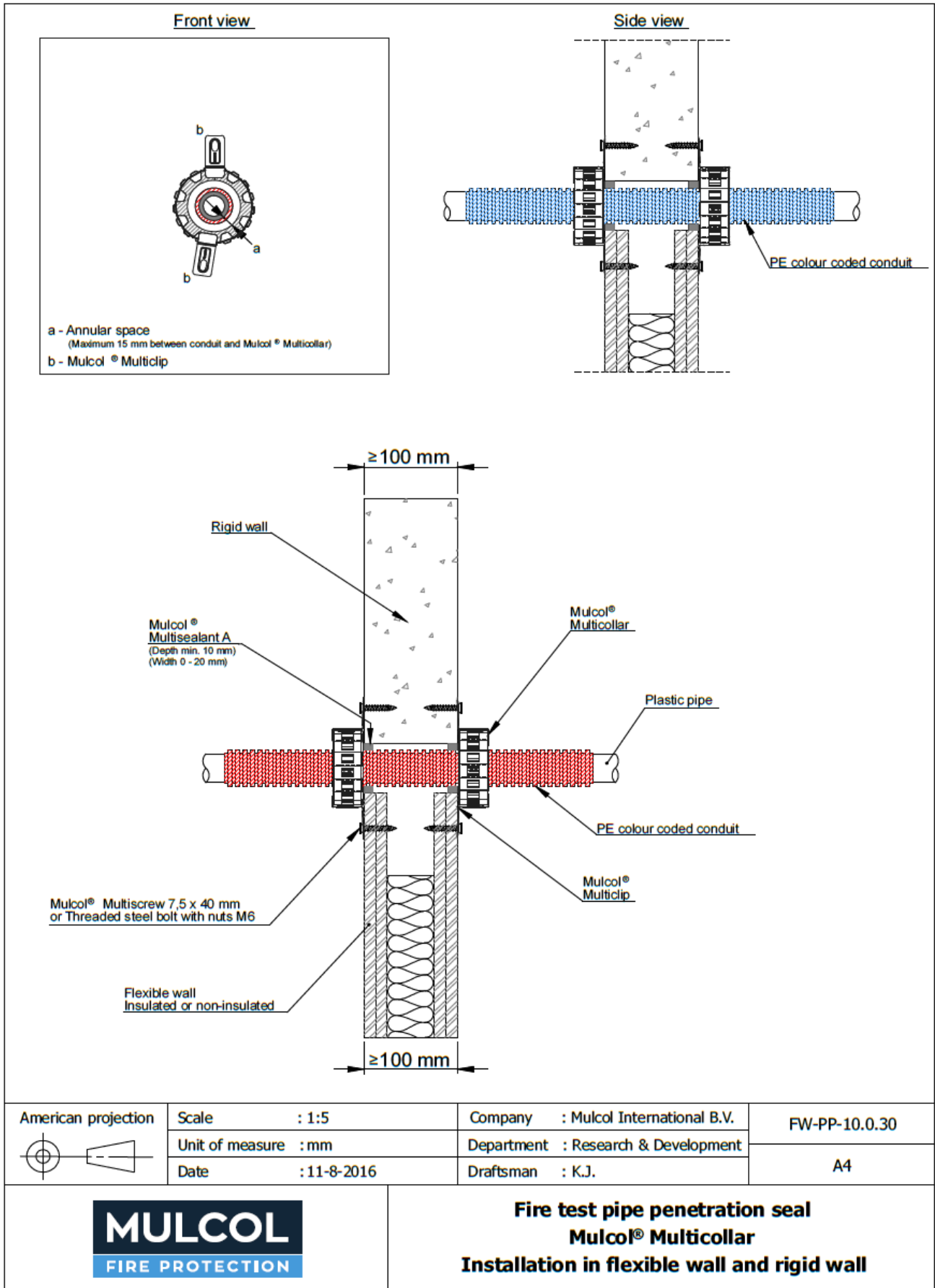

Pipe material [^]	Maximum pipe diameter mm	Pipe wall thickness mm	Conduit diameter LS/CS/LI/CI mm	No. of collars per face	Classification*
Uponor Aqua PE-Xa pipes with PE conduit insulation	25	3.5	Space ≤32	one	EI 90 U/C

* U/C pipe end configuration applies to C/C also

A.1.6 Plastic pipes supported by steel half shells

A.1.6.1 Plastic pipes supported by steel supporting half shell, perpendicular to the wall, with one Mulcol® Multicollar Slim pipe collars to both sides of the wall

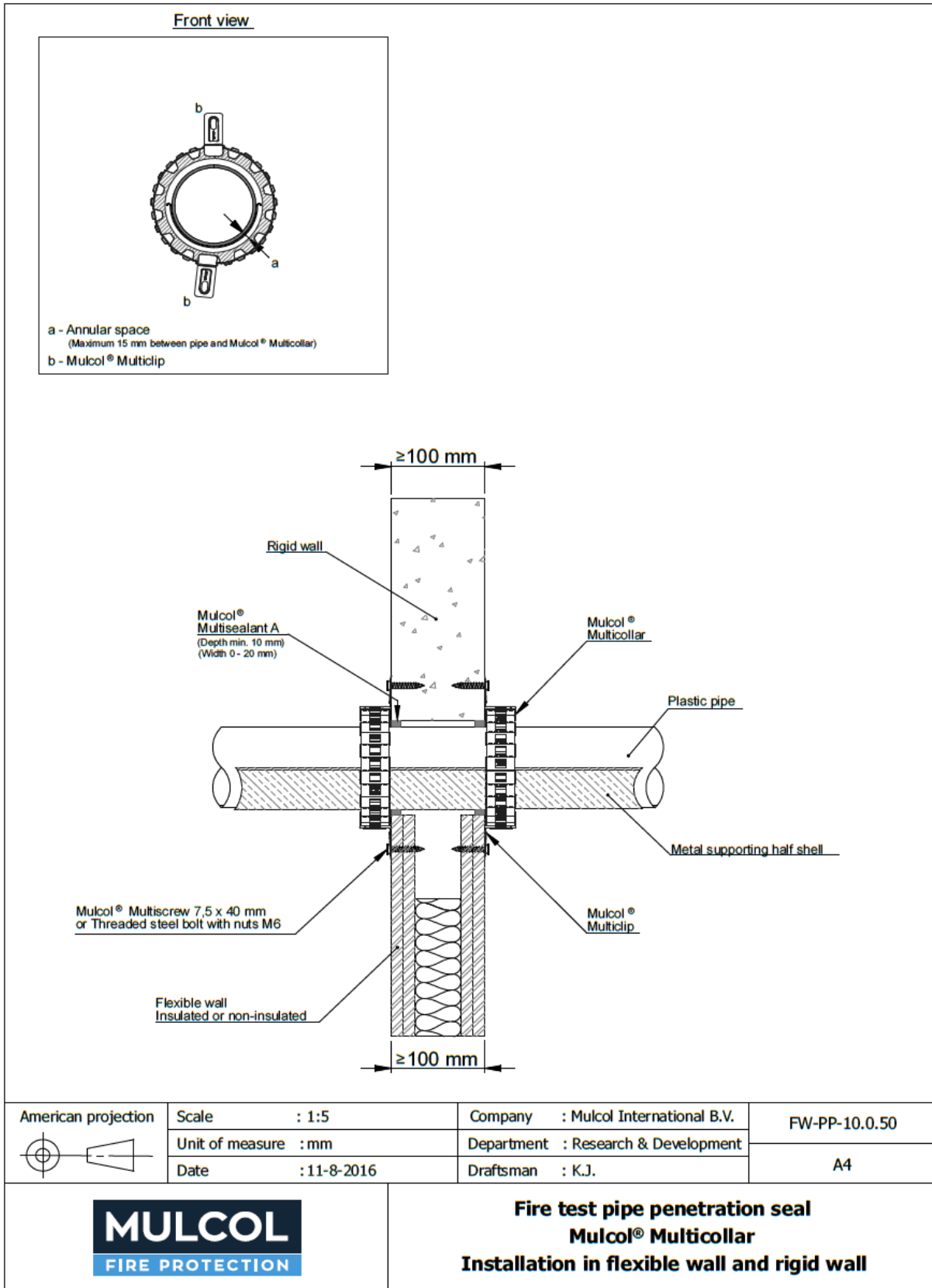

Pipe material [^]	Maximum pipe diameter mm	Pipe wall thickness mm	No. of collars per face	Classification*
PE-HD / PE / ABS / SAN+PVC	90	2.8	one	EI 90 U/C

* U/C pipe end configuration applies to C/C also

A.2 Plastic pipes (Silent)

A.2.1 Plastic pipes (Silent) in regular configurations

A.2.1.1 Plastic pipes (silent), perpendicular to the wall, with one or two Mulcol® Multicollar Slim pipe collars to both sides of the wall.

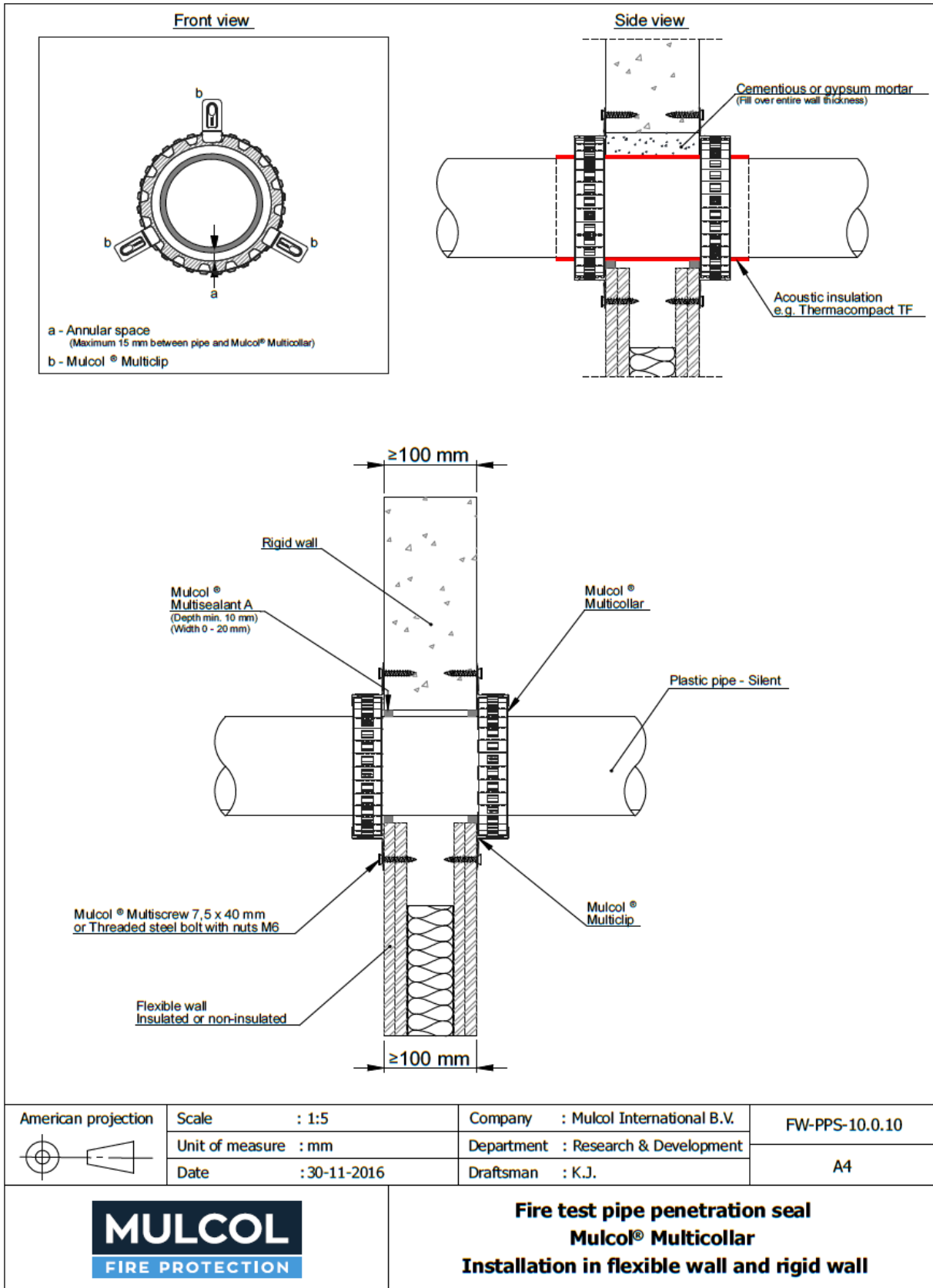

Front view

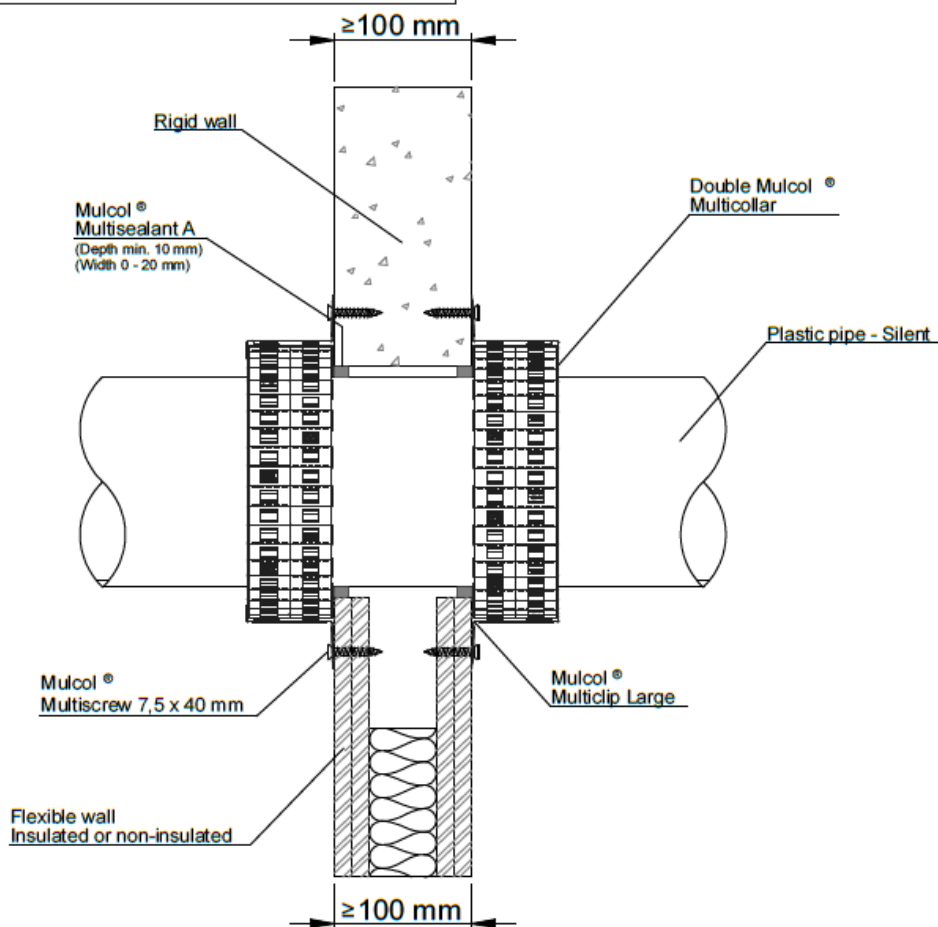
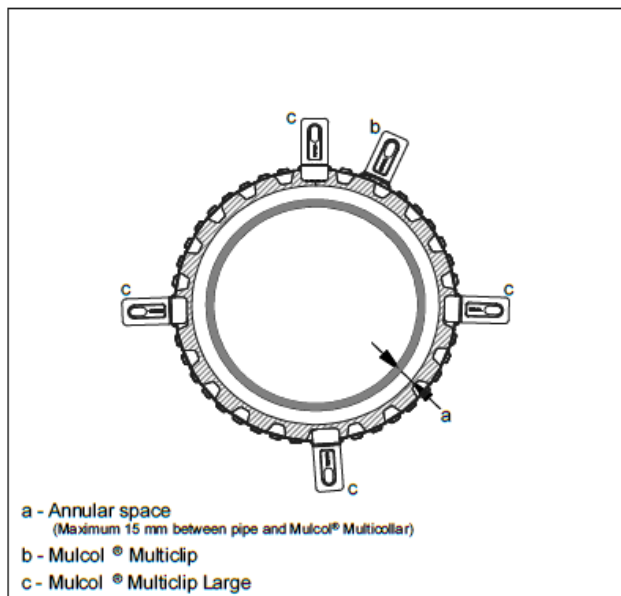

American projection

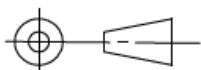

Scale : 1:5

Unit of measure : mm

Date : 28-12-2016

Company : Mulcol International B.V.

Department : Research & Development

Draftsman : K.J.

FW-PPS-20.0.10

A4



Fire test pipe penetration seal
Mulcol® Multicollar
Installation in flexible wall and rigid wall

Pipe material [^]	Maximum pipe diameter mm	Pipe wall thickness mm	No. of collars per face	Classification*
Wavin	32	2.0-3.6	one	EI 120 U/U
SiTech+	110	3.6		E 120 U/U EI 90 U/U
Geberit Silent dB 20		6.0		EI 120 U/U
Wavin SiTech+	160	5.0	two	E 120 U/U EI 90 U/U

* U/U pipe end configuration applies to U/C, C/U and C/C also

[^] Pipes may optionally be fitted with up to 4 mm thick sound decoupling insulation, min. 50 mm long (LS/CS/LI/CI)

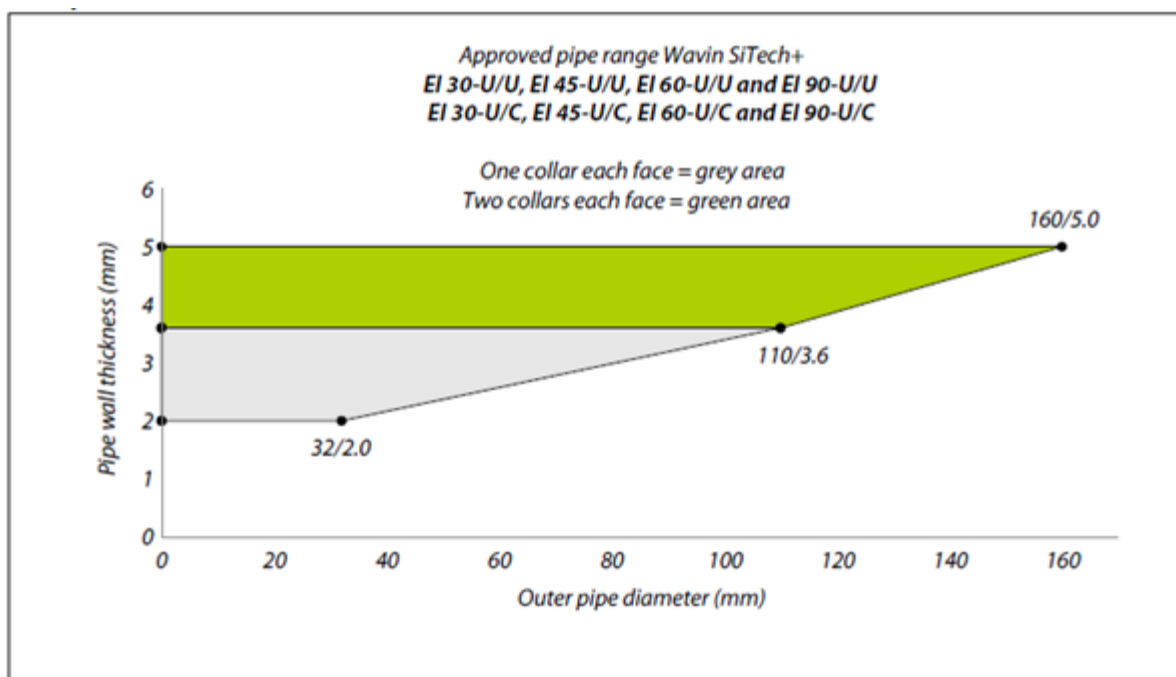

A.2.2 Plastic pipes (Silent) with sockets

A.2.2.1 Plastic pipes (silent) with moulded socket, perpendicular to the wall, with one Mulcol® Multicollar Slim pipe collar to both sides of the wall.

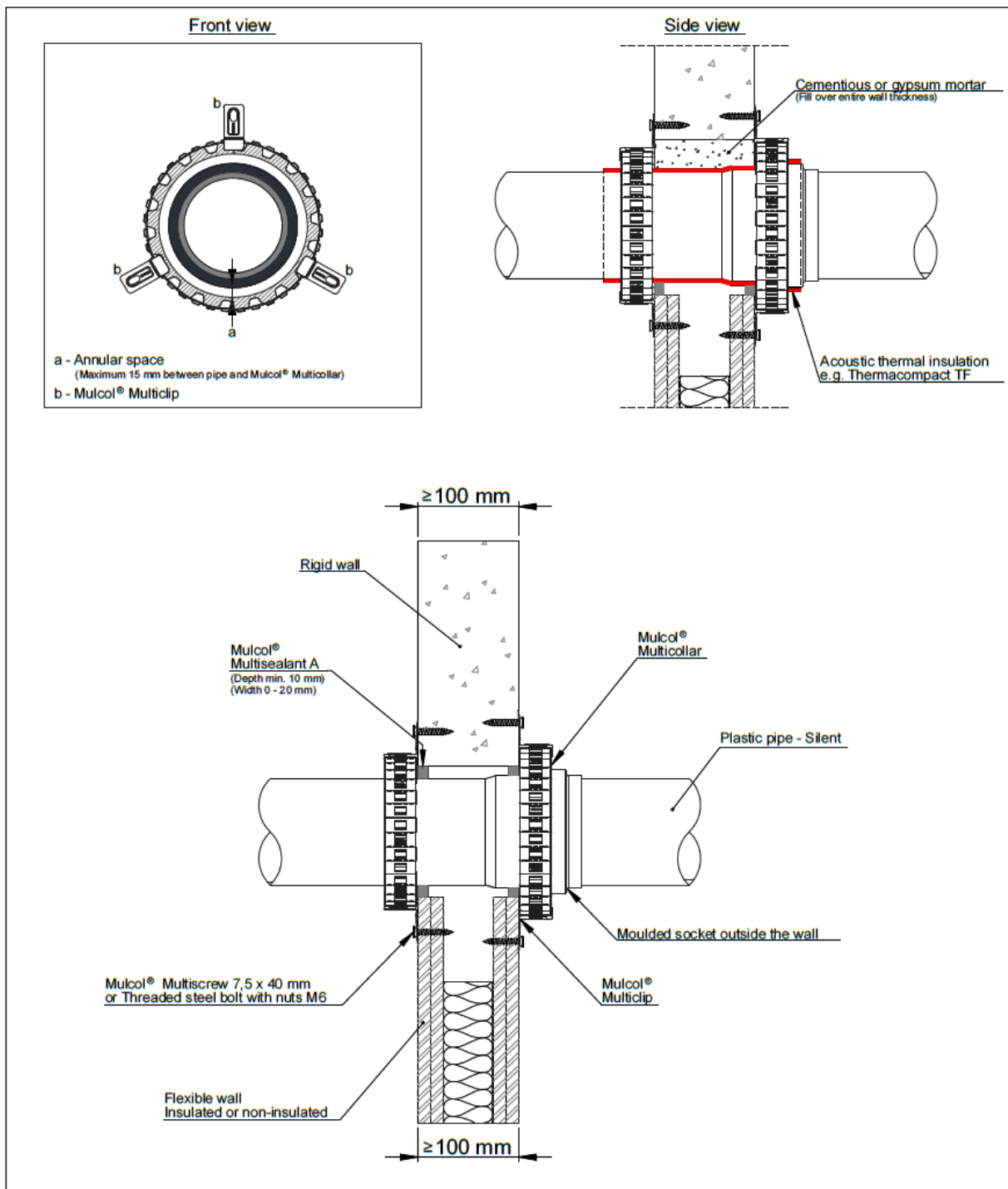

	Scale : 1:5	Company : Mulcol International B.V.	FW-PPS-10.0.60
	Unit of measure : mm	Department : Research & Development	
	Date : 30-11-2016	Draftsman : K.J.	A4
		Fire test pipe penetration seal Mulcol® Multicollar Installation in flexible wall and rigid wall	

Pipe material^	Maximum pipe diameter	Pipe wall thickness	Type of	No. of collars	Classification*
----------------	-----------------------	---------------------	---------	----------------	-----------------

	mm	mm	coupling	per face	
Raupiano Plus	110	2.7	Raupiano Plus Ø110 mm Moulded socket	one	EI 120 U/U

* U/U pipe end configuration applies to U/C, C/U and C/C also

^ Pipes may optionally be fitted with up to 4 mm thick sound decoupling insulation, min. 50 mm long (LS/CS/LI/CI)

A.2.3 Plastic pipes (Silent) with an elbow

A.2.3.1 Plastic pipes (silent) with an elbow, perpendicular to the wall, with one Mulcol® Multicollar Slim pipe collar to both sides of the wall in an 'U' shape.

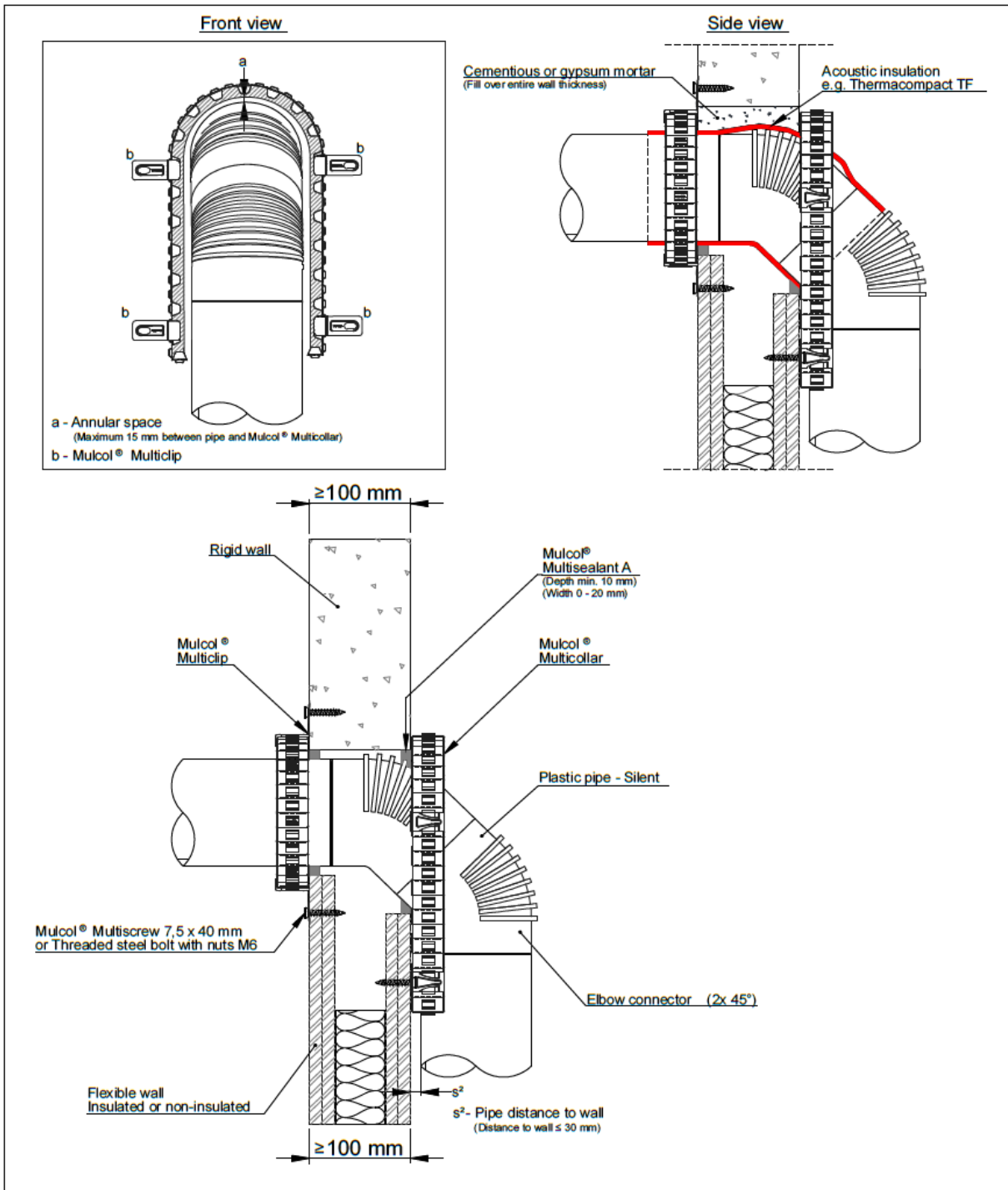

American projection 	Scale : 1:5	Company : Mulcol International B.V.	FW-PPS-50.0.80
	Unit of measure : mm	Department : Research & Development	A4
Date : 30-11-2016	Draftsman : K.J.		

Fire test pipe penetration seal
Mulcol® Multicollar
Installation in flexible wall and rigid wall

Pipe material [^]	Maximum pipe diameter mm	Pipe wall thickness mm	No. of collars per face	Classification*
Wavin SiTech+	110	3.6	one	EI 60 U/U
Geberit Silent dB 20		6.0		E 120 U/U EI 90 U/U

* U/U pipe end configuration applies to U/C, C/U and C/C also

[^] Pipes may optionally be fitted with up to 4 mm thick sound decoupling insulation, min. 50 mm long (LS/CS/LI/CI)

A.2.4 Plastic pipes (Silent) with zero distance to the floor

A.2.4.1 Plastic pipes (silent), perpendicular to the wall, in wall corner, with one Mulcol® Multicollar Slim pipe collars to both sides of the wall.

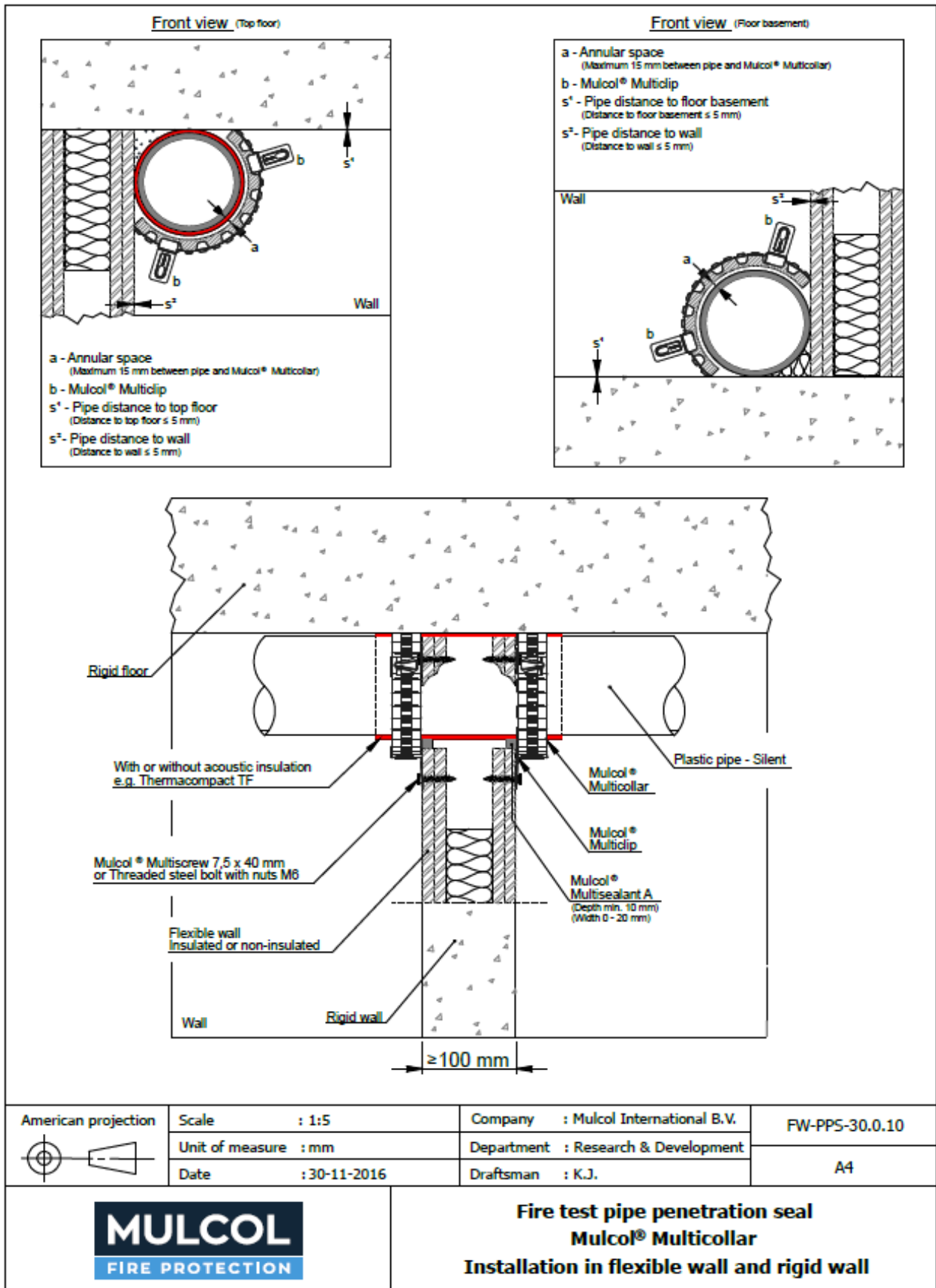

Pipe material [^]	Maximum pipe diameter mm	Pipe wall thickness mm	No. of collars per face	Location	Classification*
Geberit Silent dB 20	110	6.0	one	Bottom corner	EI 120 U/U
				Top corner	EI 60 U/U

* U/U pipe end configuration applies to U/C, C/U and C/C also

[^] Pipes may optionally be fitted with up to 4 mm thick sound decoupling insulation, min. 50 mm long (LS/CS/LI/CI)

A.3 PP-R multilayer pipes

A.3.1 PP-R multilayer pipes in regular configurations

A.3.1.1 PP-R multilayer pipes, perpendicular to the wall, with one Mulcol® Multicollar Slim pipe collars to both sides of the wall.

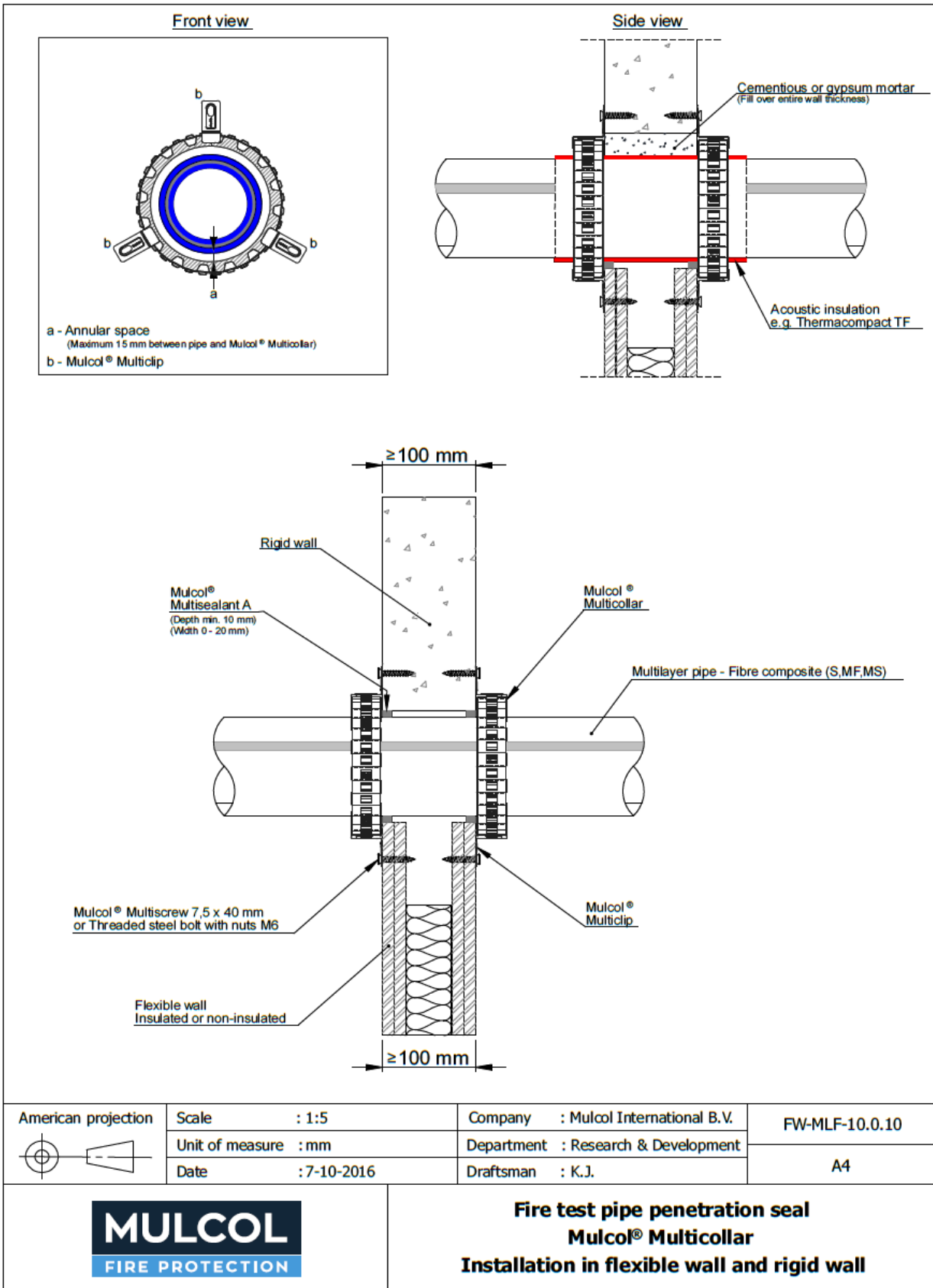

Pipe material [^]	Maximum pipe diameter mm	Pipe wall thickness mm	No. of collars per face	Classification*
Aquatherm Blue-MF	20	2.8	one	EI 90 U/C
	160	14.6		EI 90 U/C
Aquatherm Red-MF	110	15.1		

* U/C pipe end configuration applies to C/C also

[^] Pipes may optionally be fitted with up to 4 mm thick sound decoupling insulation, min. 50 mm long (LS/CS/LI/CI)

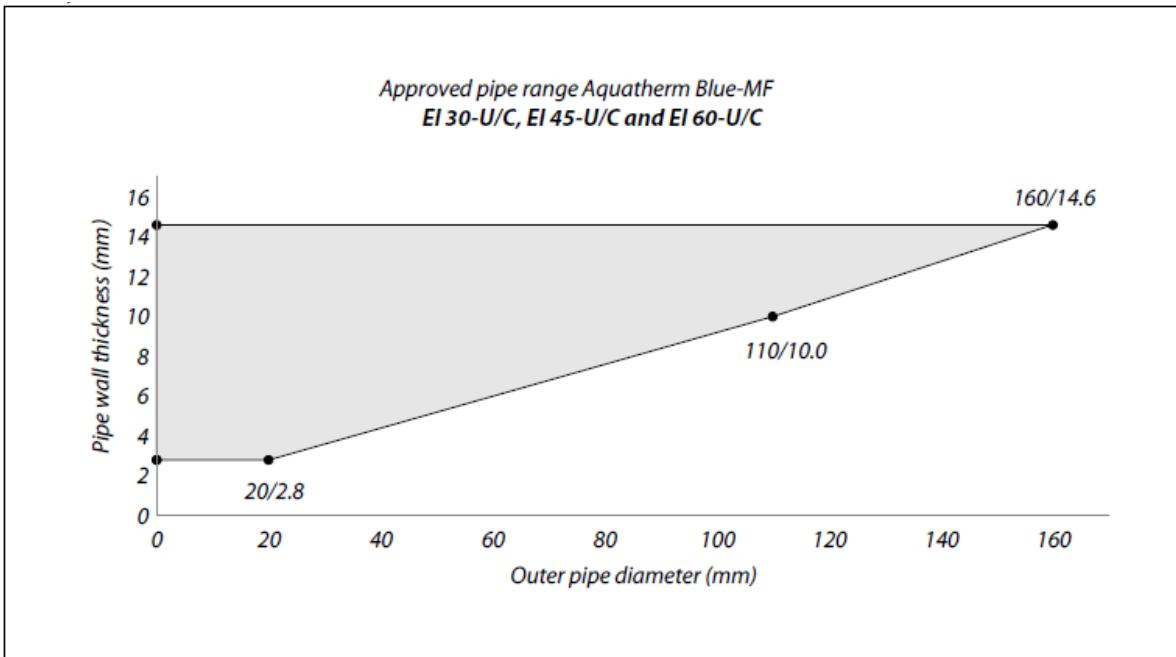

Approved pipe range Aquatherm Blue-MF
EI 90-U/C

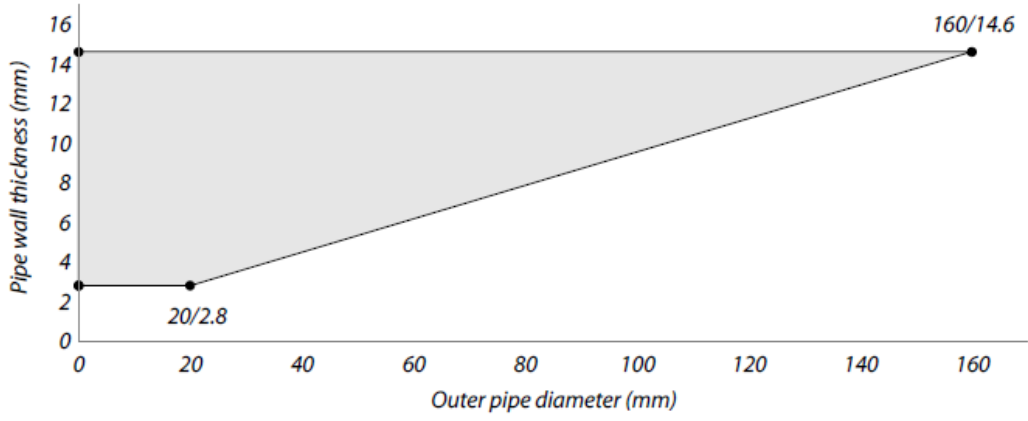

A.3.1.2 PP-R multilayer pipes, perpendicular to the wall, in Mulcol® Multimastic FB1 coated board seals , with one Mulcol® Multicollar Slim pipe collars to both sides of the seal.

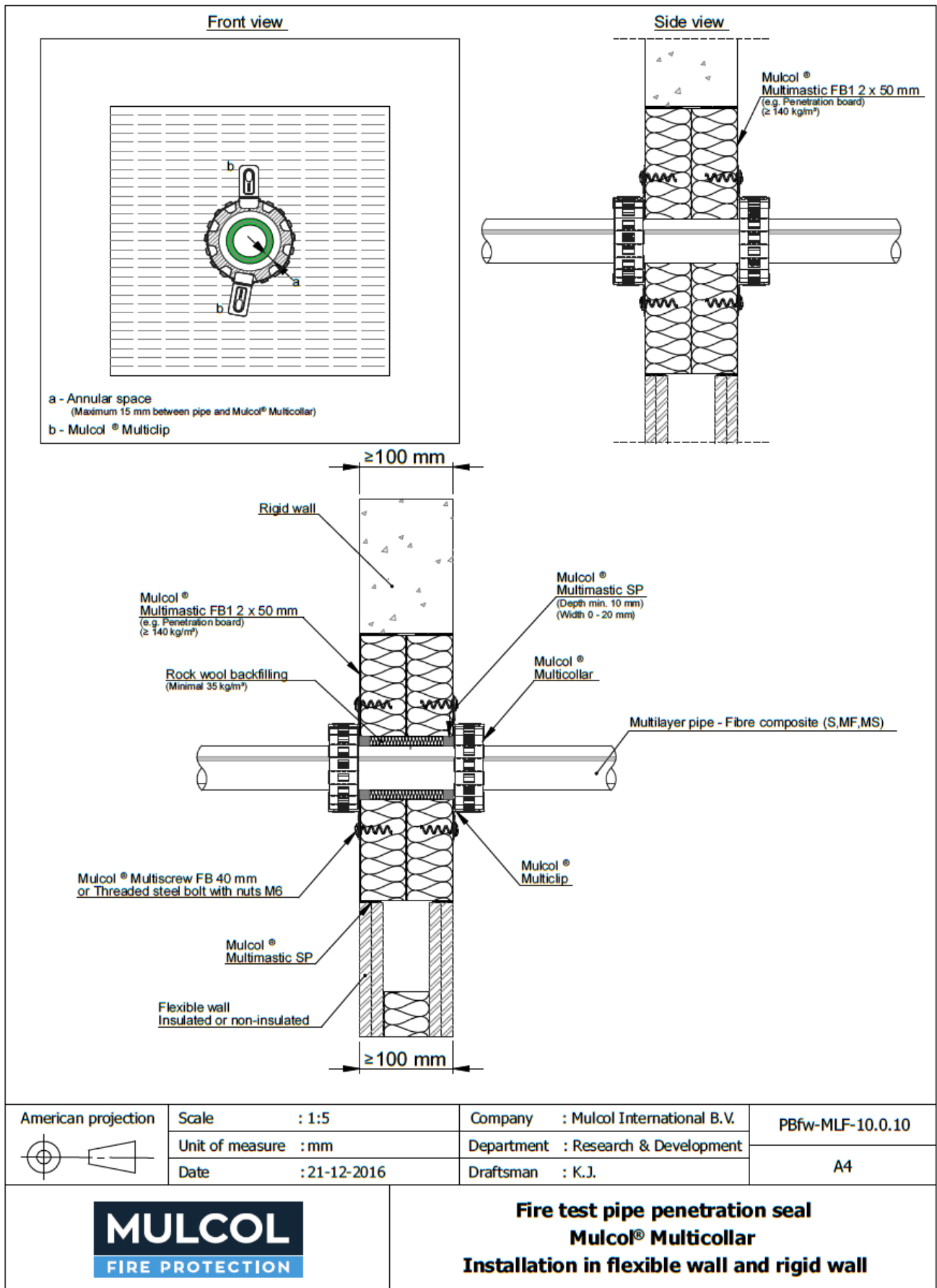

Pipe material	Maximum pipe diameter mm	Pipe wall thickness mm	No. of collars per face	Classification*
Aquatherm	50	6.9-10.0	one	EI 120 U/C
Green-MF	110	10.0		

* U/C pipe end configuration applies to C/C also

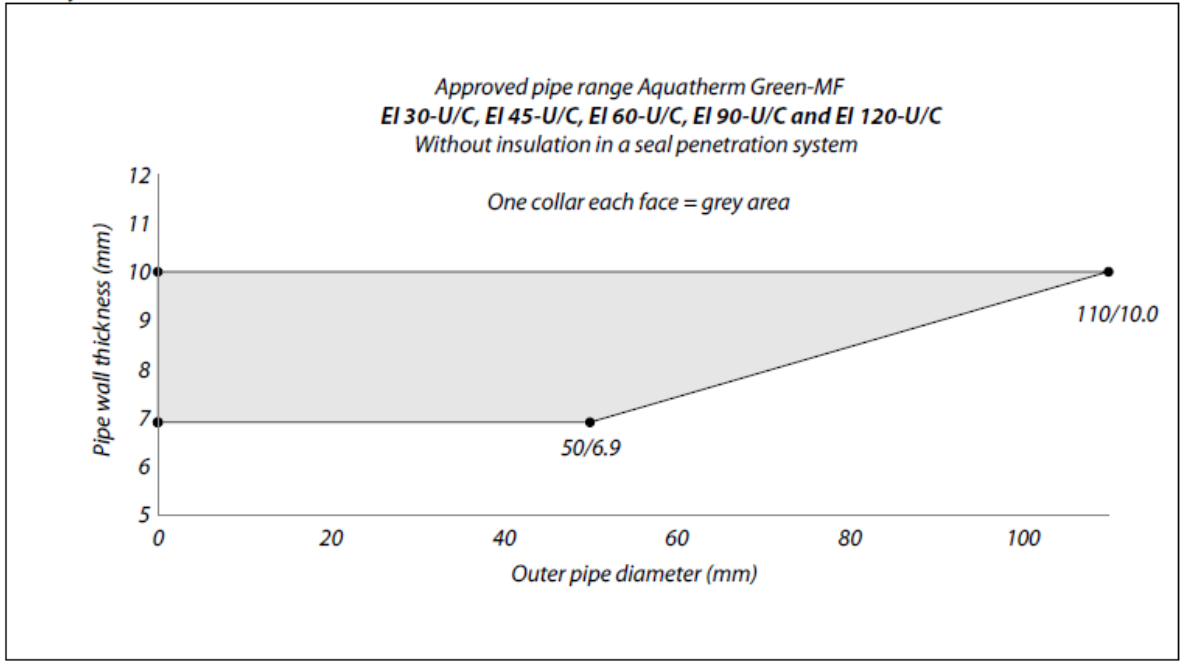

A.3.1.3 PP-R multilayer pipes insulated with AF/Armaflex made out of flexible elastomeric EPDM rubber foam with a min. reaction to fire class BL-s3, d0 or B-s3 or, d0 (to EN 13501-1), perpendicular to the wall, with one Mulcol® Multicollar Slim pipe collars to both sides of the wall.

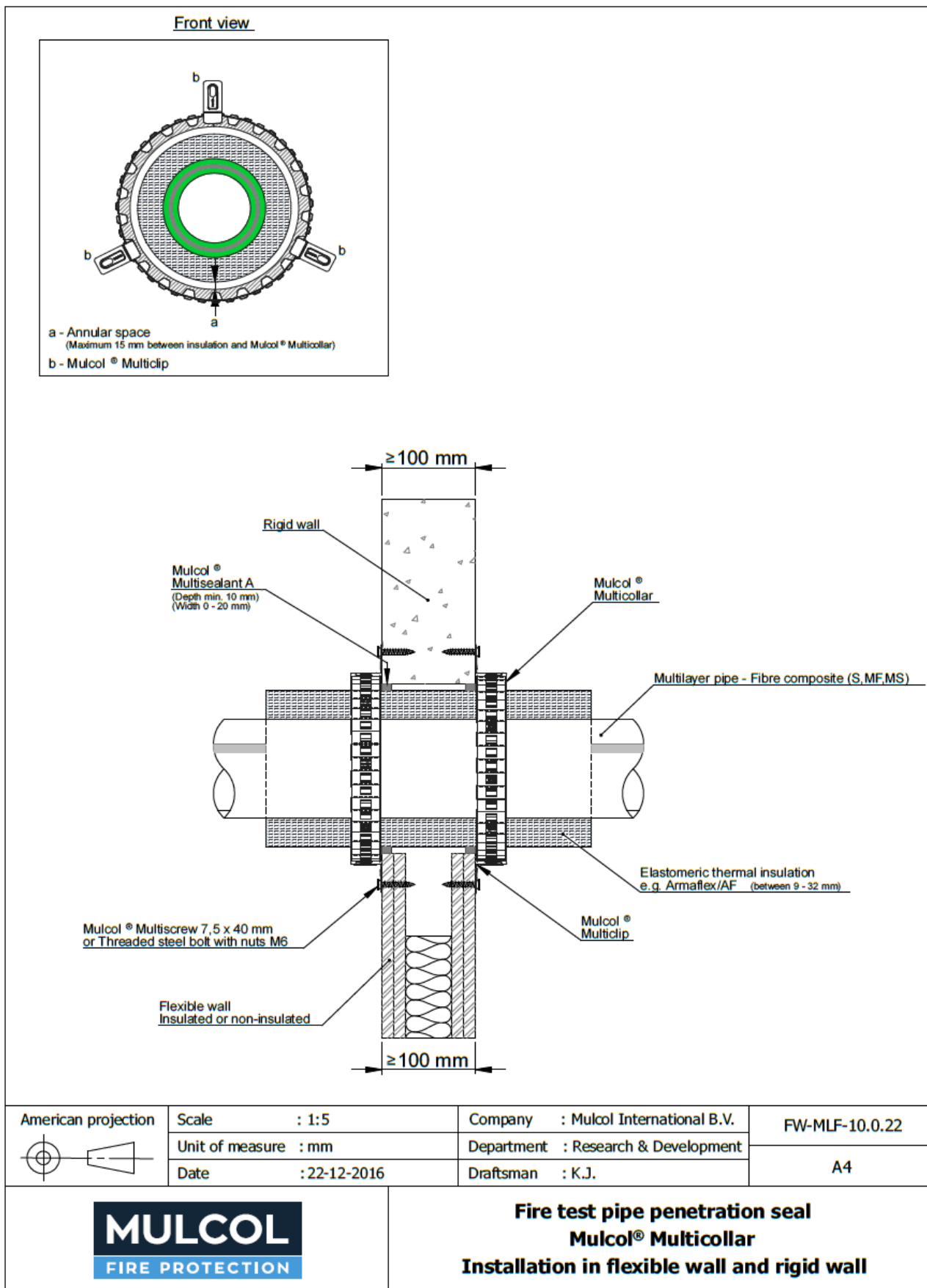

Pipe material [^]	Maximum pipe diameter mm	Pipe wall thickness mm	Insulation LS/CS/LI/CI thickness/length mm	No. of collars per face	Classification*
Aquatherm Green-S	110	18.3	9-32 / 500 (min.)	One	EI 90 U/C
Aquatherm Green-MS		15.2			
Aquatherm Green-MF		15.1			
Aquatherm Blue-MF	20	2.8	9 / 500 (min.)		EI 120 U/C
	110	10.0			E 120 U/C EI 90 U/C

* U/C pipe end configuration applies to C/C also

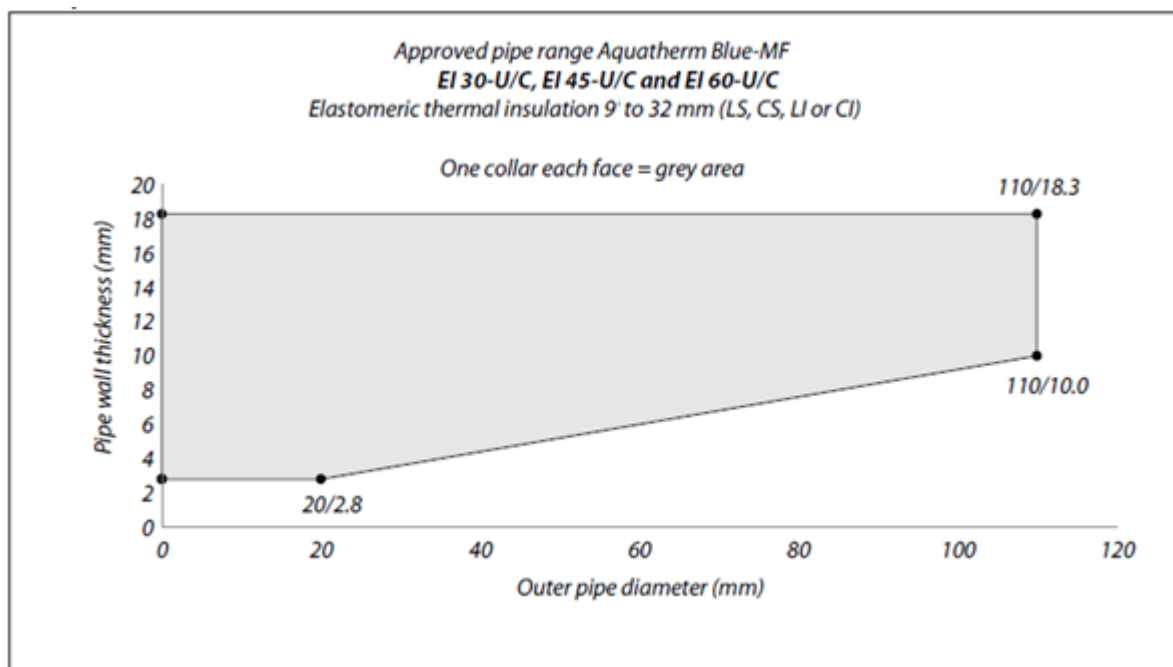

A.3.1.4 PP-R multilayer pipes insulated with AF/Armaflex made out of flexible elastomeric EPDM rubber foam with a min. reaction to fire class BL-s3, d0 or B-s3 or, d0 (to EN 13501-1), perpendicular to the wall, with one Mulcol® Multicollar Slim pipe collars to both sides of the wall

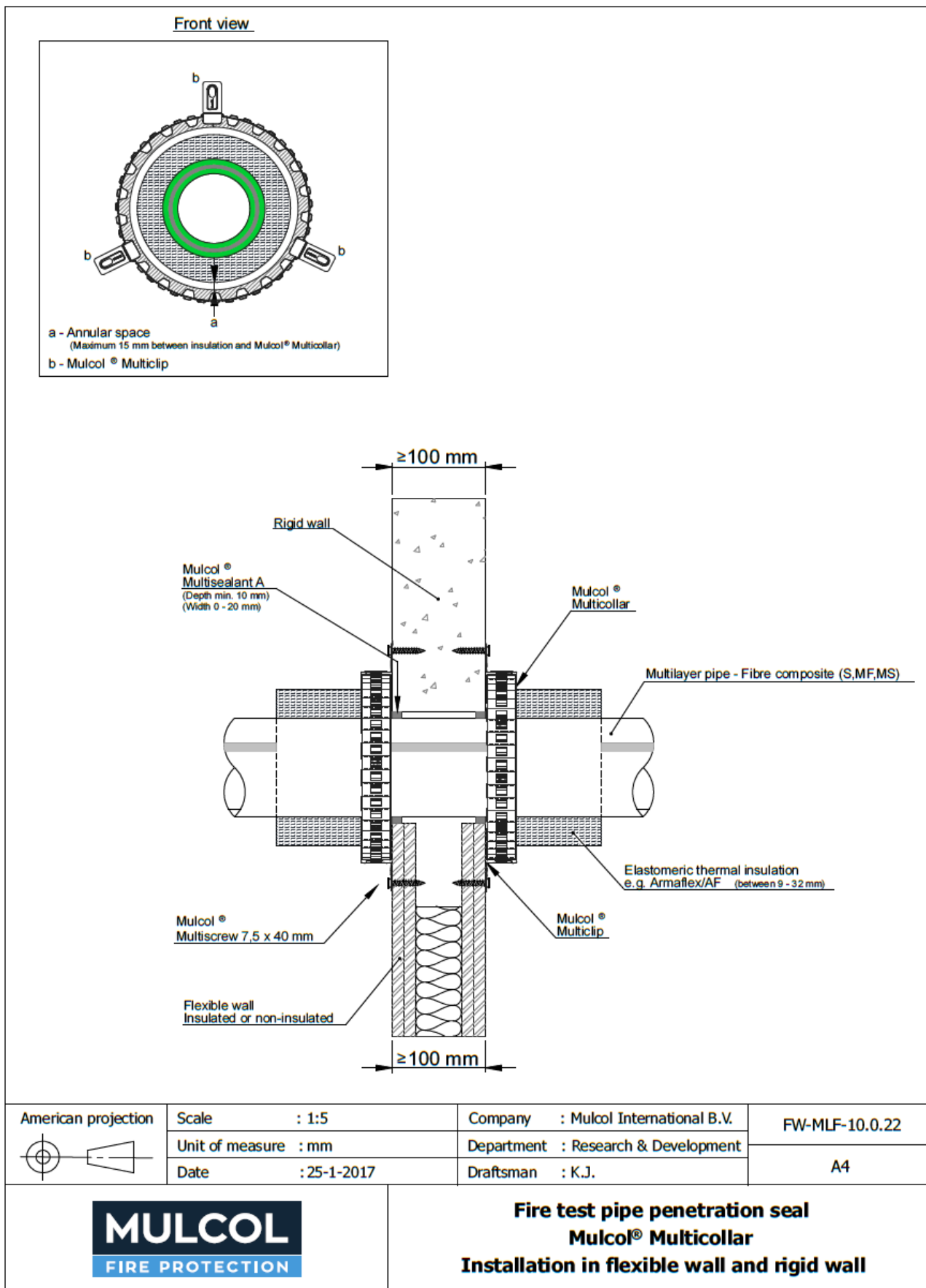

Pipe material [^]	Maximum pipe diameter mm	Pipe wall thickness mm	Insulation LI/CI thickness/ length mm	No. of collars per face	Classification*
Aquatherm Blue-MF	110	10.0-14.6	32 / 300 (min.)	One	EI 120 U/C
	160	14.6			
	110	10.0-14.6	9-32 / 300 (min.)		EI 90 U/C
	160	14.6			

* U/C pipe end configuration applies to C/C also

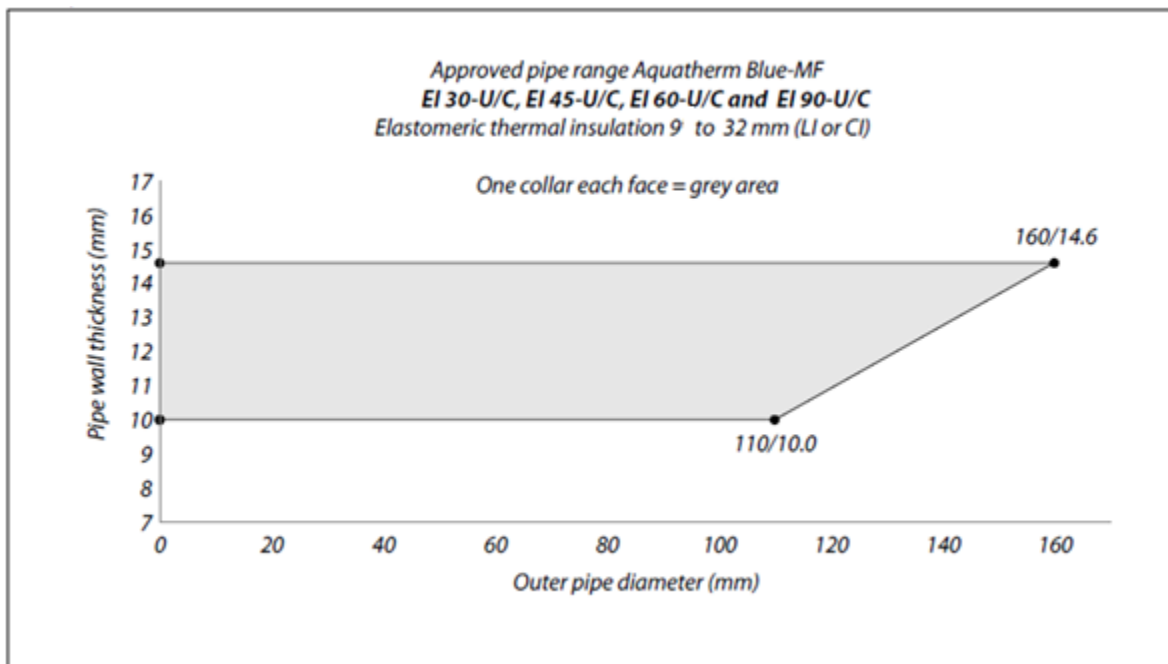

Approved pipe range Aquatherm Blue-MF
EI 30-U/C, EI 45-U/C, EI 60-U/C, EI 90-U/C and EI 120-U/C
Elastomeric thermal insulation 32 mm (LI or CI)

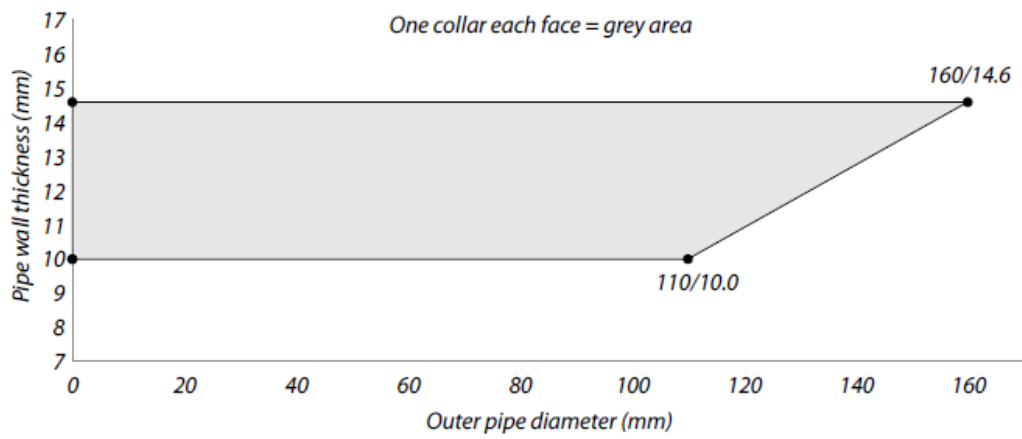

A.3.1.5 PP-R multilayer pipes insulated with AF/Armaflex made out of flexible elastomeric EPDM rubber foam with a min. reaction to fire class BL-s3, d0 or B-s3 or, d0 (to EN 13501-1), in Mulcol® Multimastic FB1 coated board seals, perpendicular to the wall, with one Mulcol® Multicollar Slim pipe collars to both sides of the wall

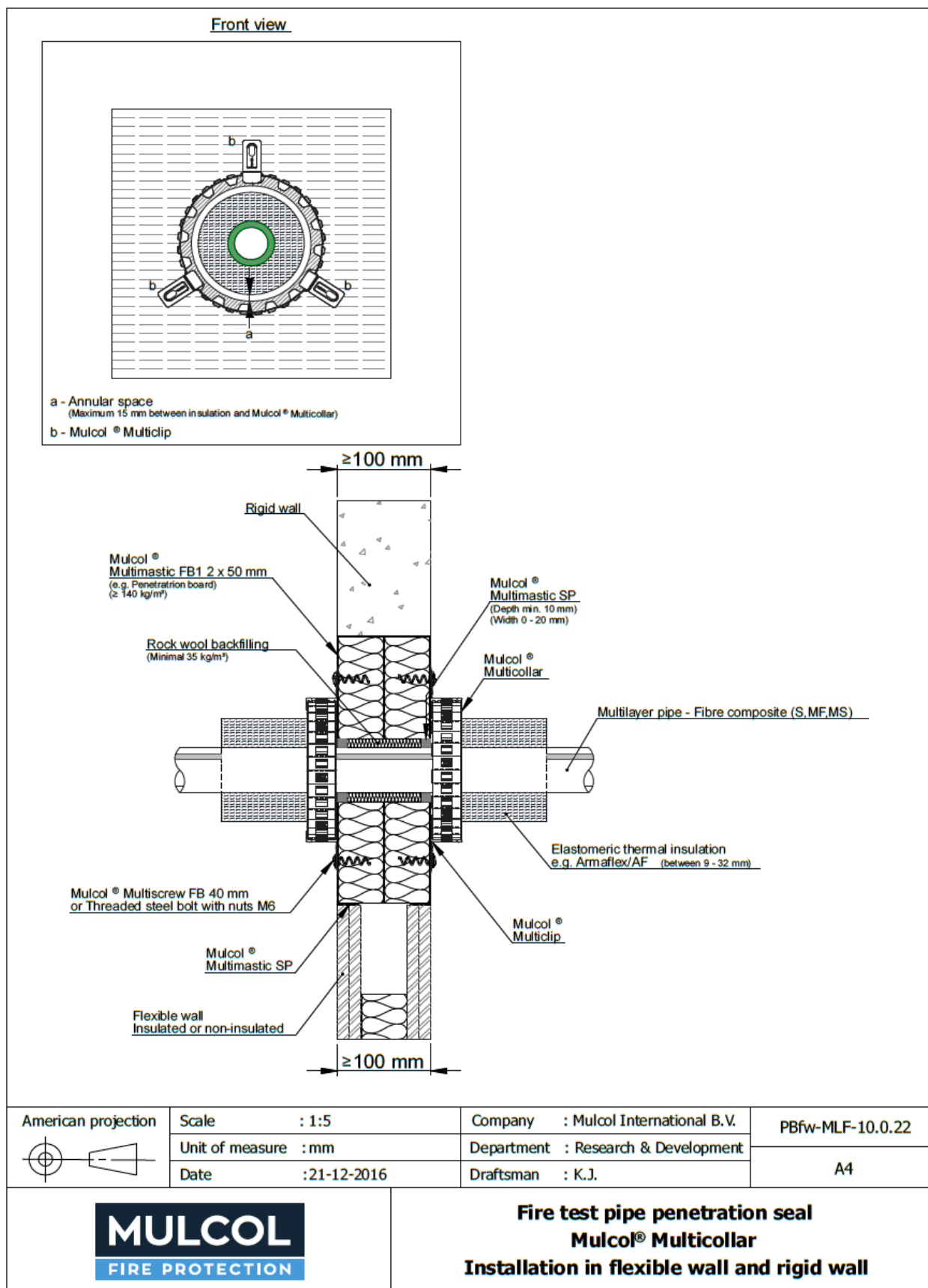

Pipe material [^]	Maximum pipe diameter mm	Pipe wall thickness mm	Insulation LI/CI thickness/length mm	No. of collars per face	Classification*
Aquatherm Green-MF	50	6.9	9-32 / 300 (min.)	One	EI 120 U/C

* U/C pipe end configuration applies to C/C also

A.3.2 PP-R multilayer pipes supported by steel supporting half shell

A.3.2.1 PP-R multilayer pipes supported by steel supporting half shell, perpendicular to the wall, with one Mulcol® Multicollar Slim pipe collars to both sides of the wall.

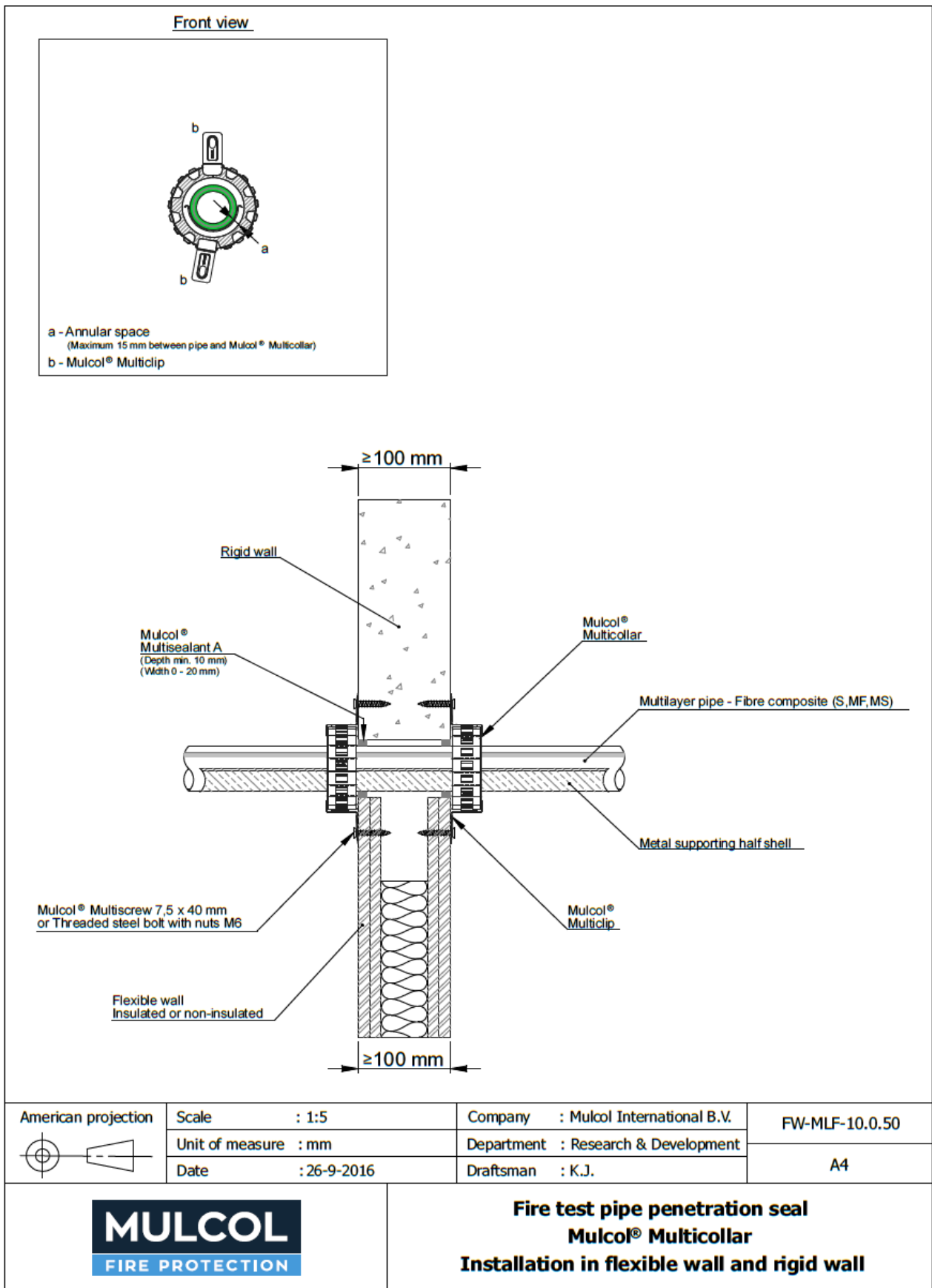

Pipe material[^]	Maximum pipe diameter mm	Pipe wall thickness mm	No. of collars per face	Classification*
Aquatherm Green-MS	50	6.9	one	EI 90 U/C

* U/C pipe end configuration applies to C/C also

A.3.3 PP-R multilayer pipes with an elbow

A.3.3.1 PP-R multilayer pipes with an elbow, perpendicular to the wall, with one Mulcol® Multicollar Slim pipe collar to both sides of the wall.

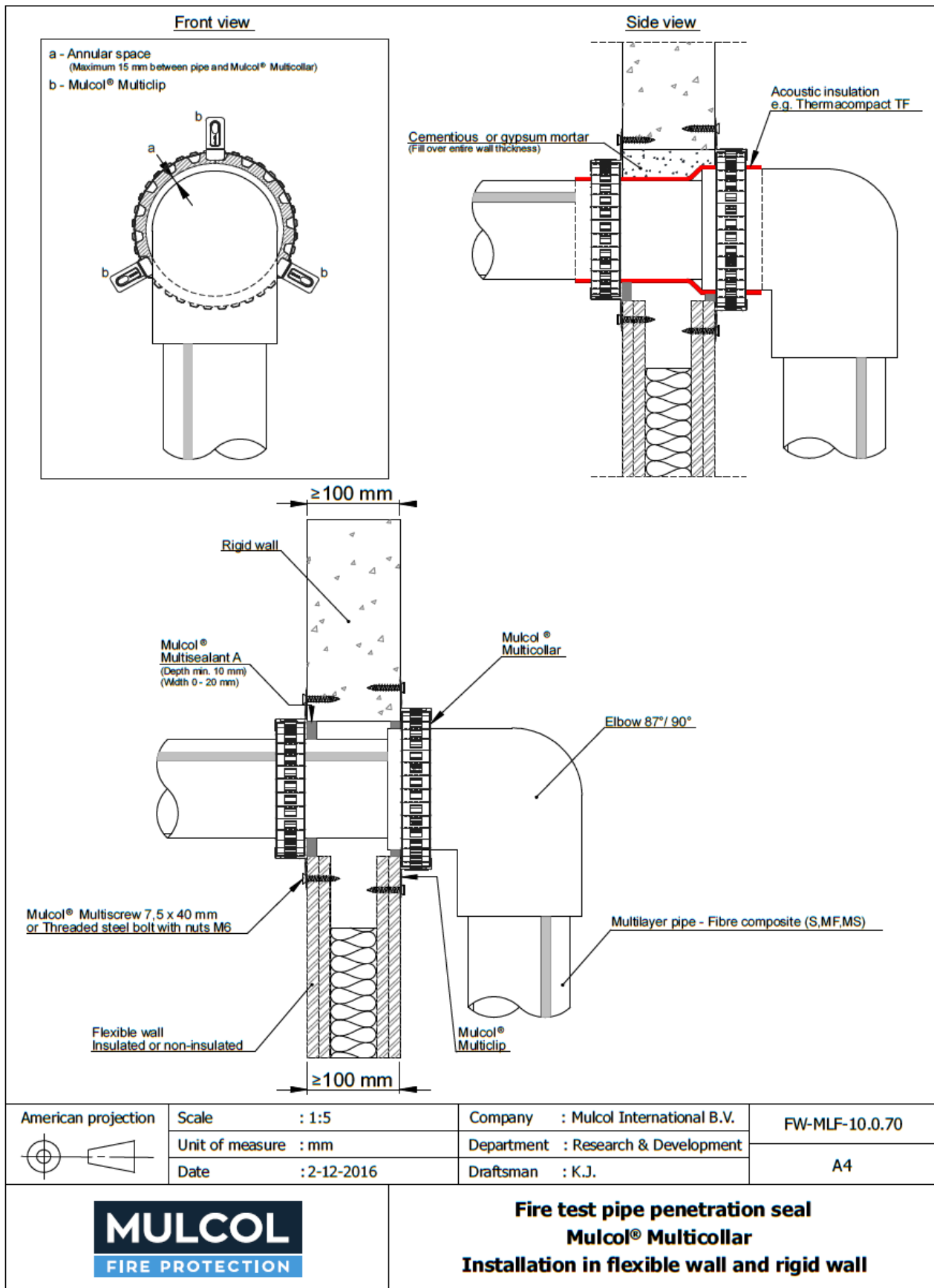

Pipe material [^]	Maximum pipe diameter mm	Pipe wall thickness mm	No. of collars per face	Classification*
Aquatherm Blue-MF and elbow PP-R	110	10.0	one	E 120 U/C EI 90 U/C

* U/C pipe end configuration applies to C/C also

[^] Pipes may optionally be fitted with up to 4 mm thick sound decoupling insulation, min. 50 mm long (LS/CS/LI/CI)

A.3.4 PP-R multilayer pipes with zero distance to the floor

A.3.4.1 PP-R multilayer pipes, perpendicular to the wall, with zero distance to the floor, with one Mulcol® Multicollar Slim pipe collars to both sides of the wall.

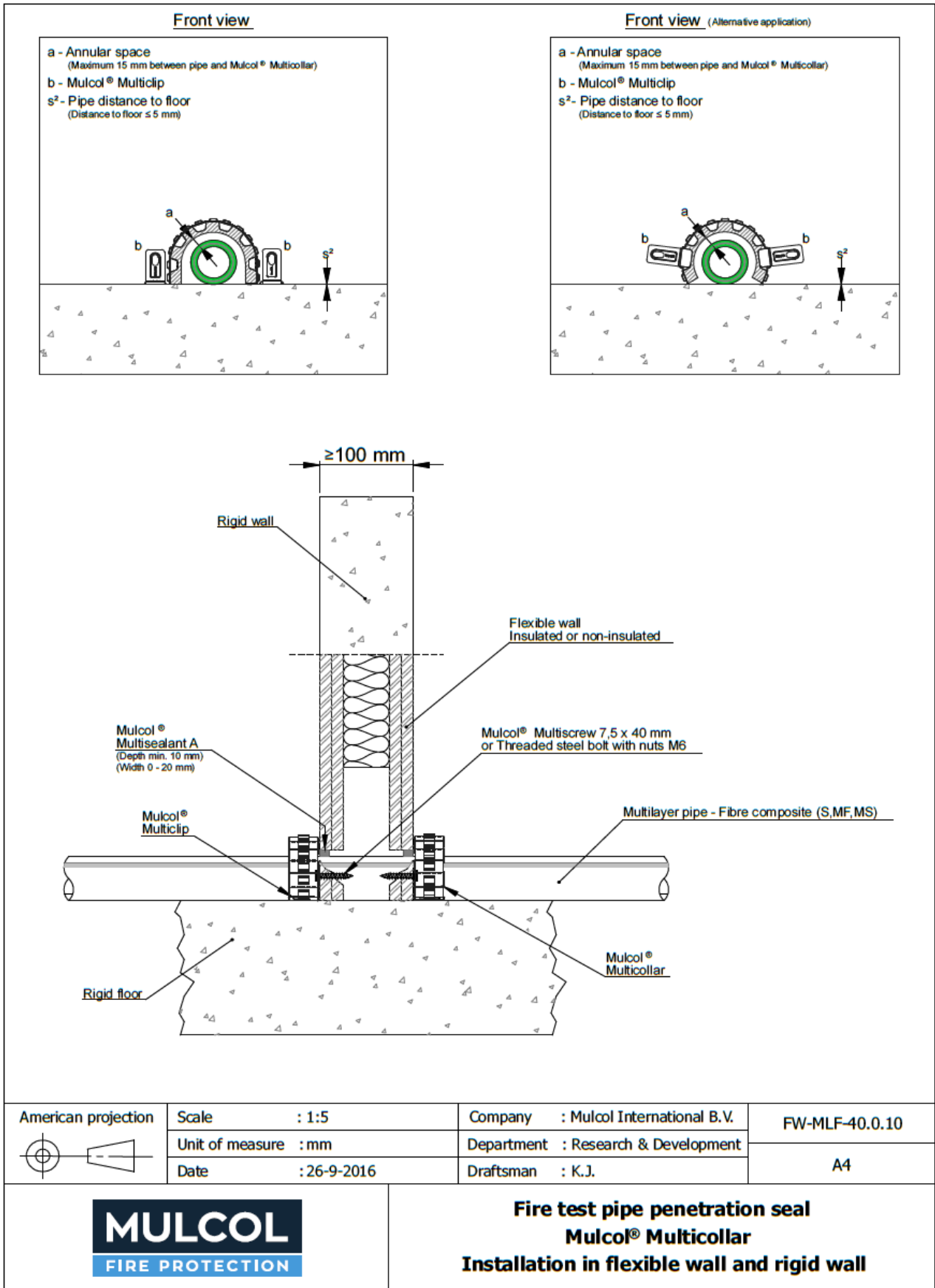

Pipe material	Maximum pipe diameter mm	Pipe wall thickness mm	No. of collars per face	Classification*
Aquatherm Green-MF	50	6.9	one	EI 90 U/C

* U/C pipe end configuration applies to C/C also

A.4.4.2 PP-R multilayer pipes insulated with AF/Armaflex made out of flexible elastomeric EPDM rubber foam with a min. reaction to fire class BL-s3, d0 or B-s3 or, d0 (to EN 13501-1), perpendicular to the wall, with zero distance to the floor, with one Mulcol® Multicollar *Slim* pipe collars to both sides of the wall.

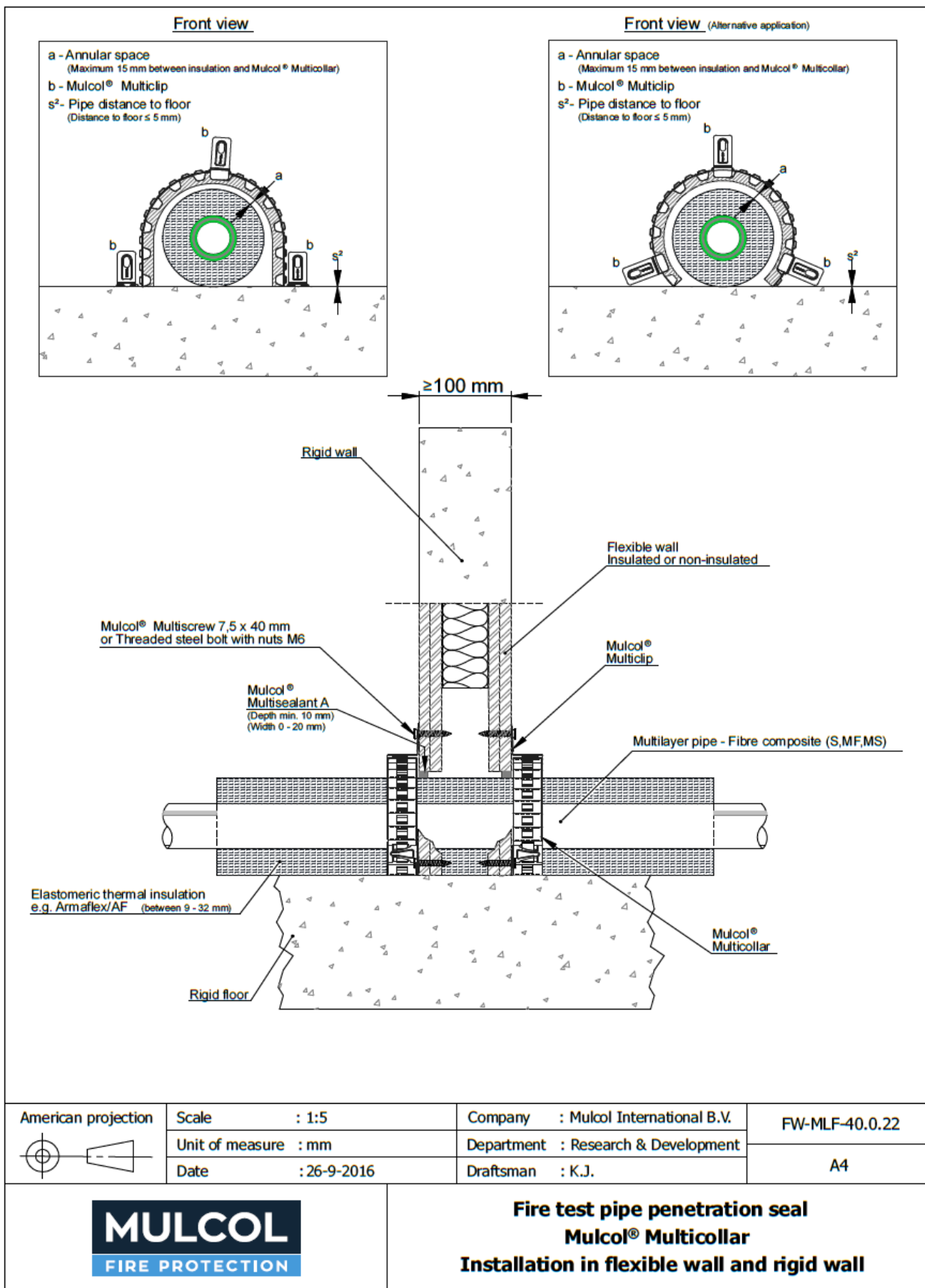

Pipe material	Maximum pipe diameter mm	Pipe wall thickness mm	Insulation LS/CS/LI/CI thickness/ length mm	No. of collars per face	Classification*
Aquatherm Green-MF	50	6.9	9-32 / 300 (min.)	One	EI 90 U/C

* U/C pipe end configuration applies to C/C also

A.4 Aluminium composite pipes

A.4.1 Aluminium composite pipes in regular configurations

A.4.1.1 Aluminium composite pipes fitted perpendicular to the wall, with one or two Mulcol® Multicollar Slim pipe collars to both sides of the wall.

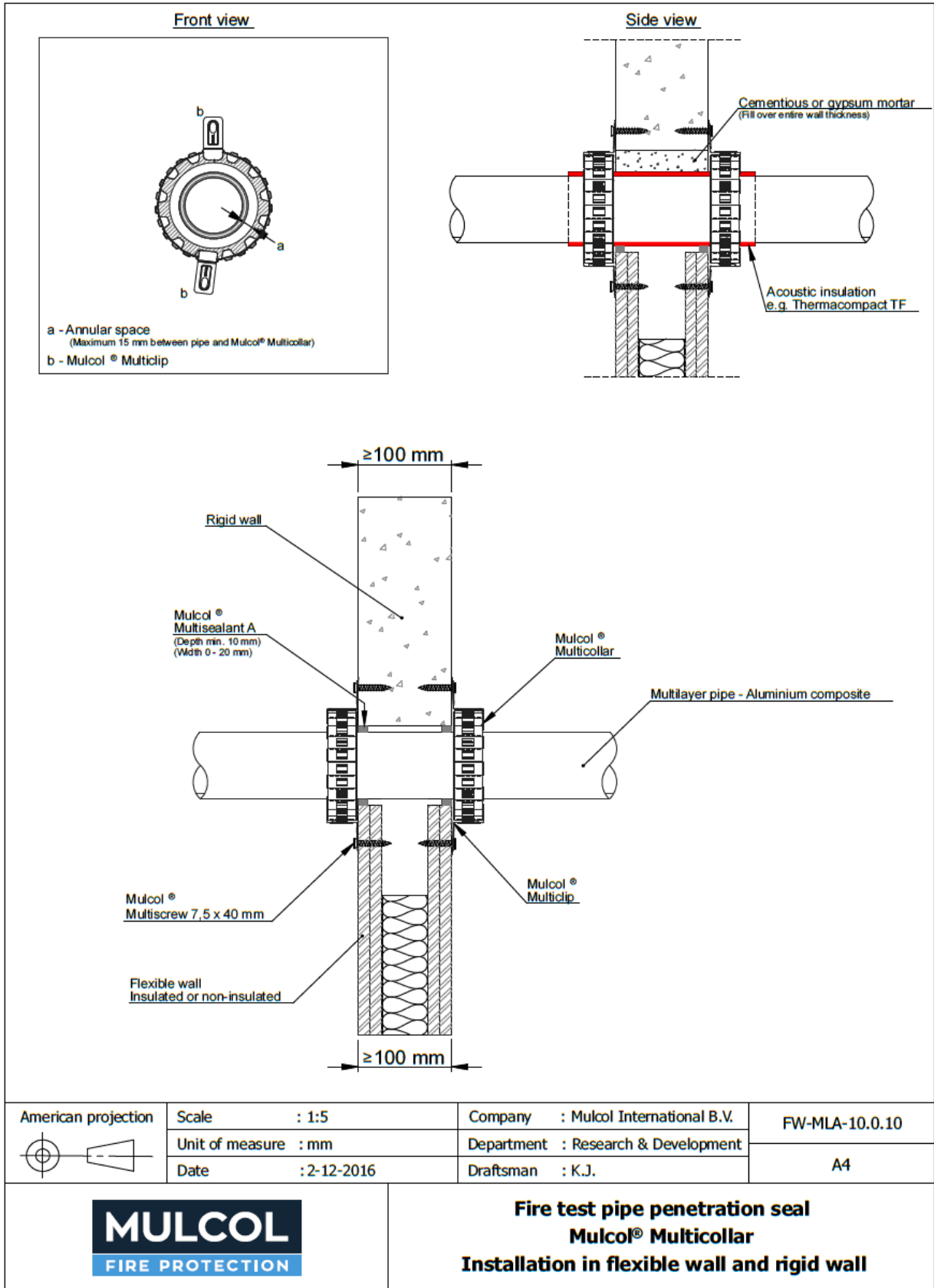

Front view

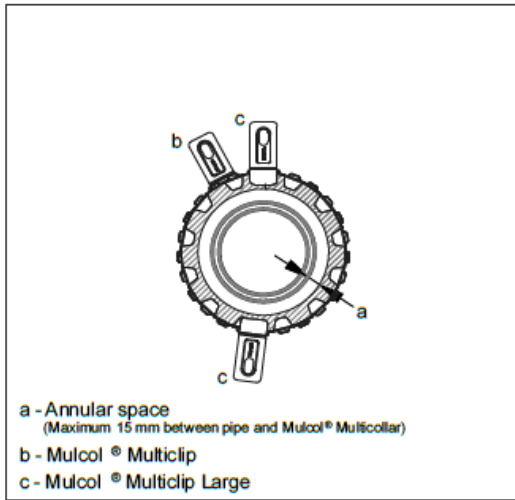

Side view

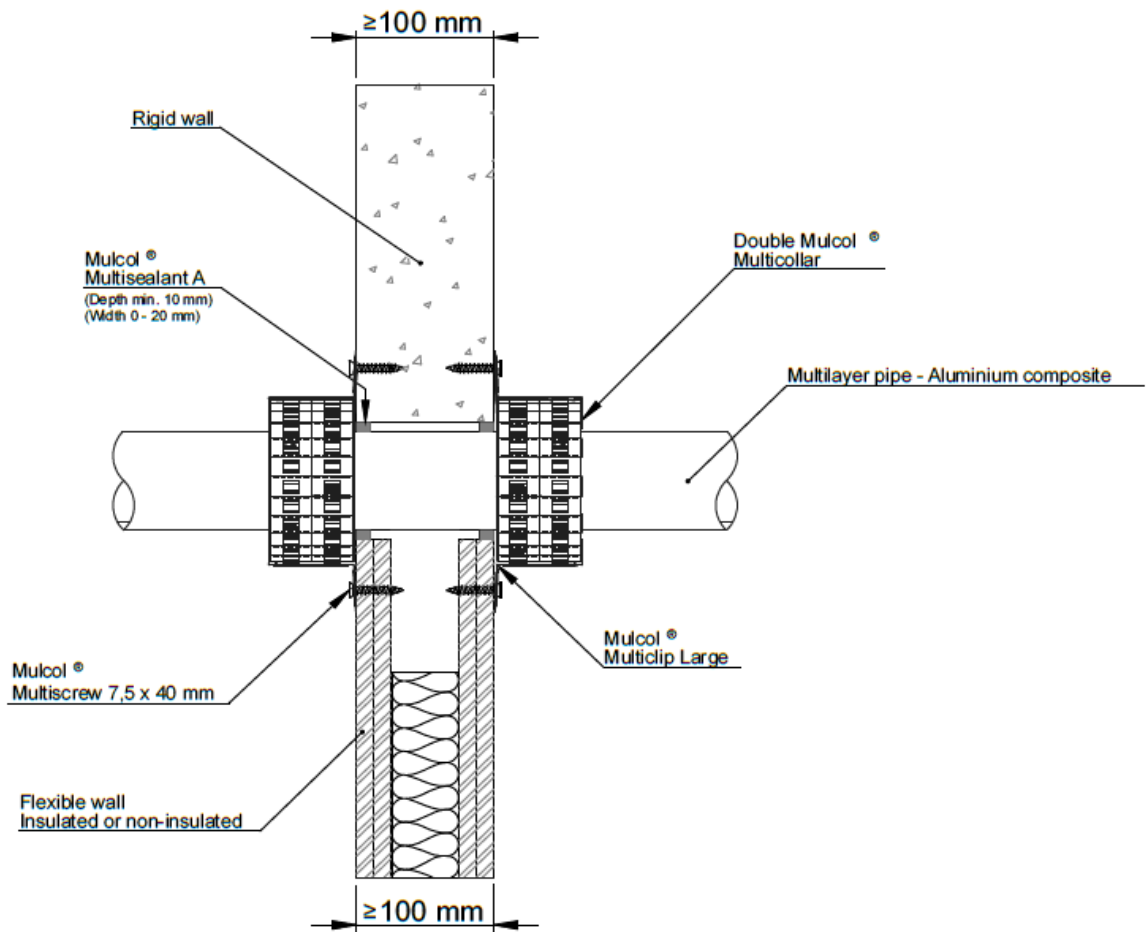
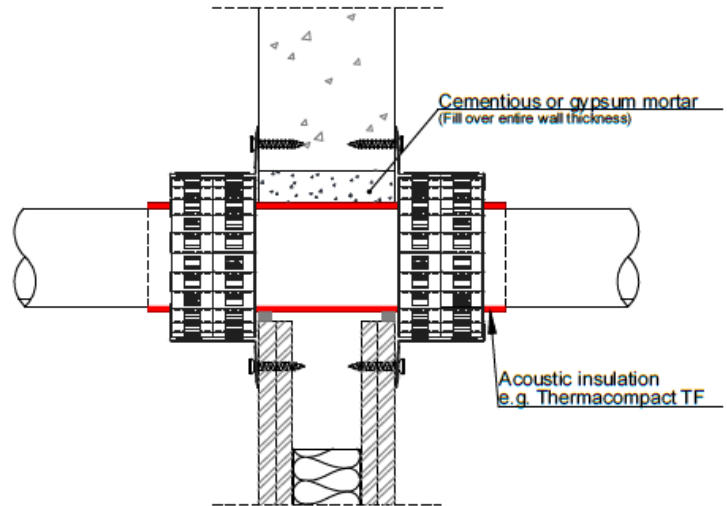

American projection 	Scale : 1:5	Company : Mulcol International B.V.	FW-MLA-20.0.10
	Unit of measure : mm	Department : Research & Development	
	Date : 5-12-2016	Draftsman : K.J.	A4



Fire test pipe penetration seal
Mulcol® Multicollar
Installation in flexible wall and rigid wall

Pipe material [^]	Maximum pipe diameter mm	Pipe wall thickness mm	No. of collars per face	Classification*
Henco PE-Xc/AL/PE-Xc	20	2.0	one	EI 120 U/C
Uponor PE-Xa Aqua Pipe	25	3.5		
Henco PE-Xc/AL/PE-Xc	32	3.0		
	40	3.5		
Uponor PE-Xa Aqua Pipe	40	4.0		
Henco PE-Xc/AL/PE-Xc	50			
Alpex Duo PE-Xb/AL/PE-Xb	63	4.5	one	E 90 U/C EI 60 U/C
Henco PE-Xc/AL/PE-Xc	75	6.0	two	E 120 U/C EI 90 U/C

* U/C pipe end configuration applies to C/C also

[^] Pipes may optionally be fitted with up to 4 mm thick sound decoupling insulation, min. 50 mm long (LS/CS/LI/CI)

A.4.1.2 Aluminium composite pipes fitted , perpendicular to the wall, in Mulcol® Multimastic FB1 coated board seals , with one or two Mulcol® Multicollar Slim pipe collars to both sides of the seal.

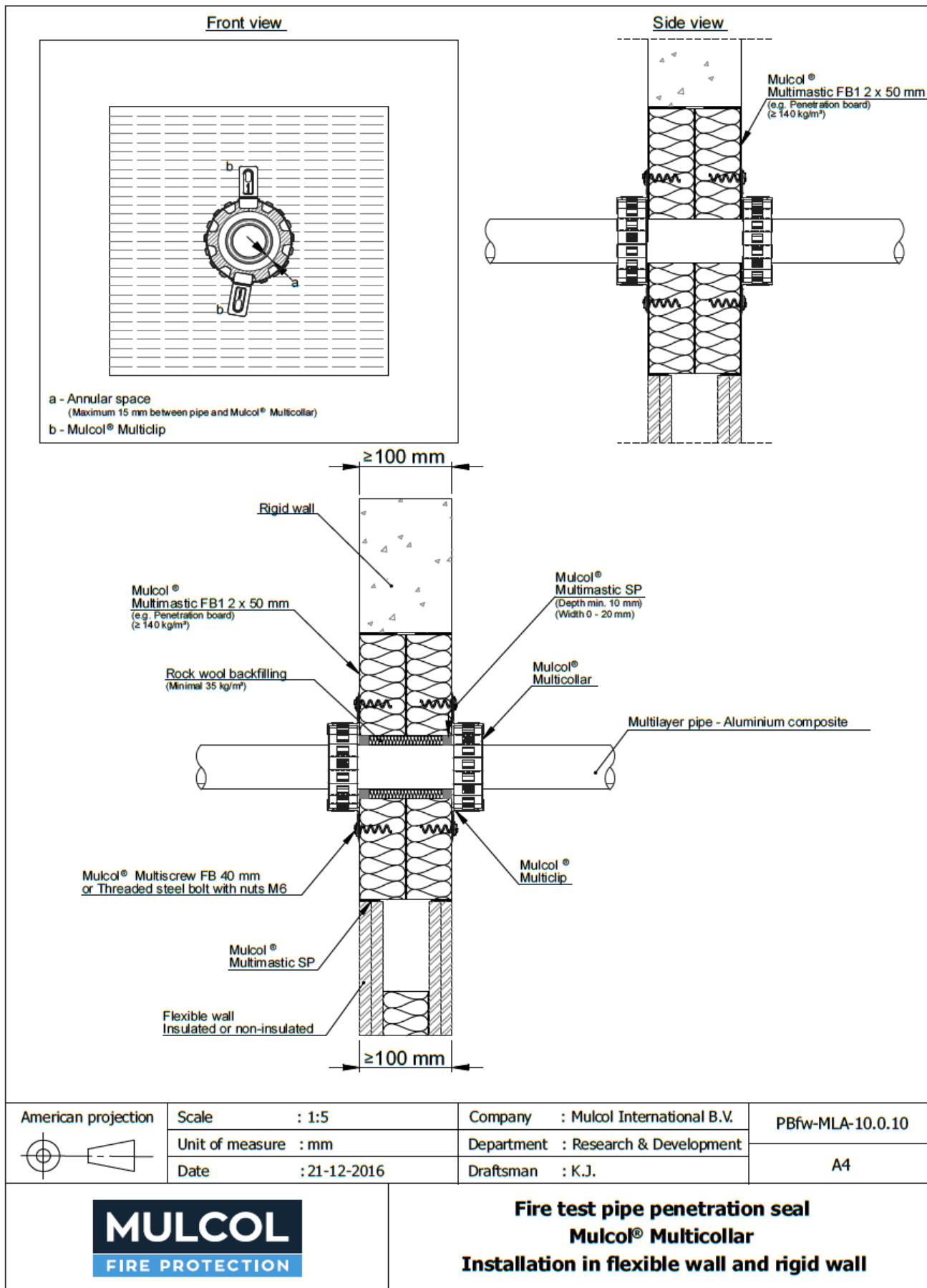

Front view

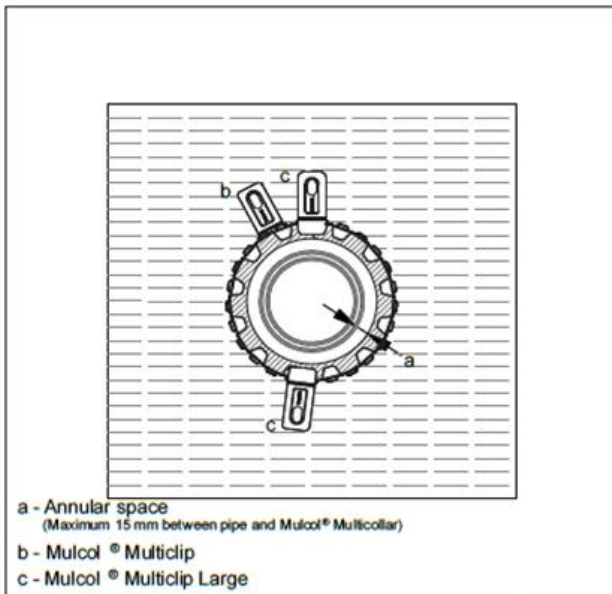

Side view

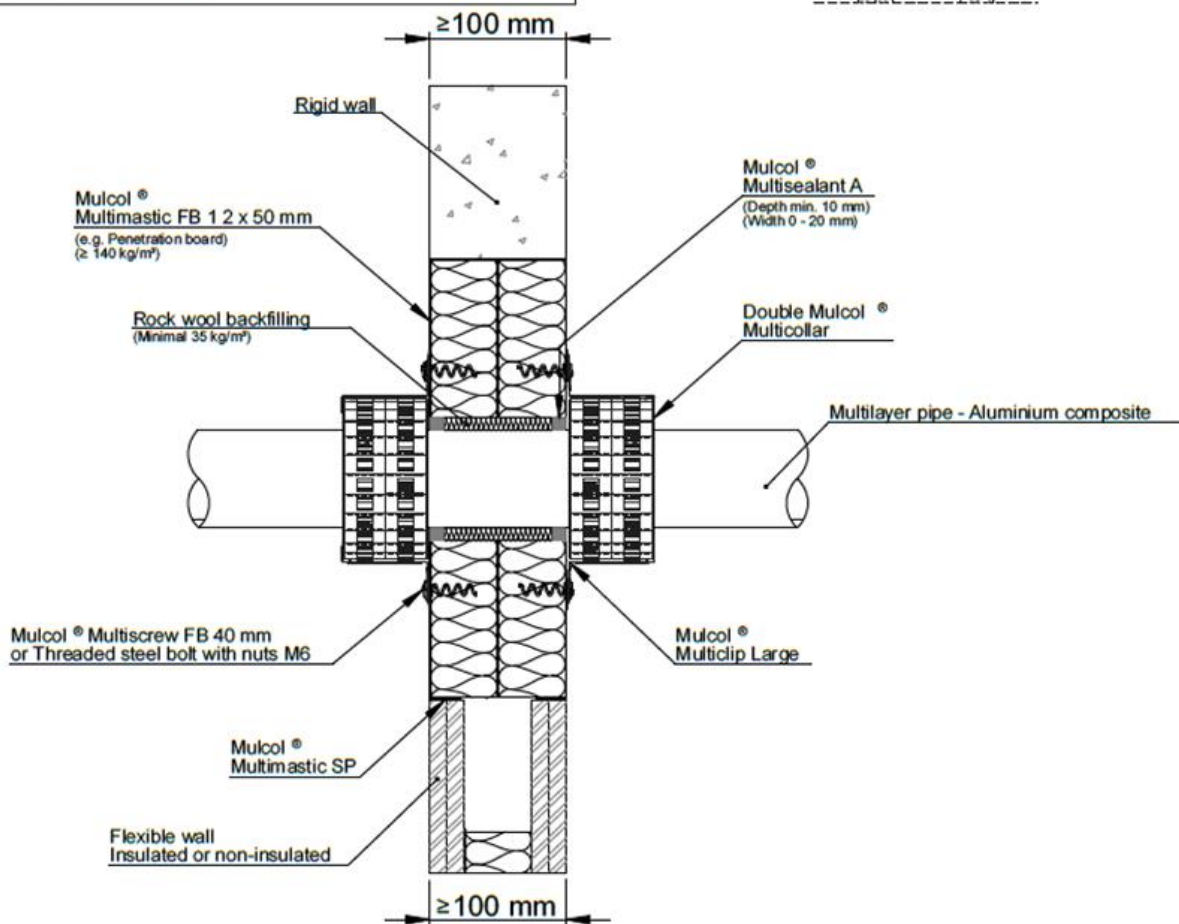
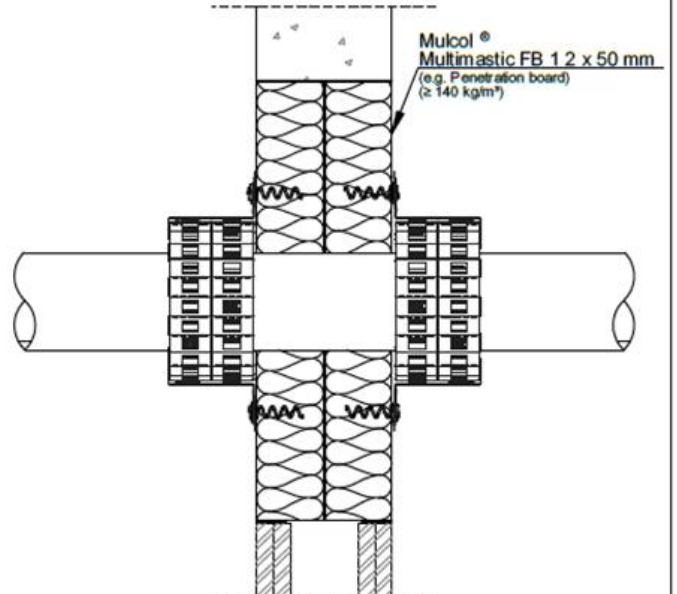

American projection

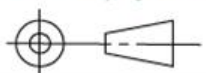

Scale : 1:5

Unit of measure : mm

Date : 30-12-2016

Company : Mulcol International B.V.

Department : Research & Development

Draftsman : K.J.

PBfw-MLA-20.0.10

A4



Fire test pipe penetration seal
Mulcol® Multicollar
Installation in flexible wall and rigid wall

Pipe material^	Maximum pipe diameter mm	Pipe wall thickness mm	No. of collars per face	Classification*
Henco PE-Xc/AL/PE-Xc	20	2.0	one	EI 120 U/C
Uponor PE-Xa Aqua Pipe	25	3.5		
Henco PE-Xc/AL/PE-Xc	32	3.0		
	40	3.5		
Uponor PE-Xa Aqua Pipe	40	4.0		
Henco PE-Xc/AL/PE-Xc	50	4.0	one	EI 120 U/C
Alpex Duo PE-Xb/AL/PE-Xb	63	4.5		E 120 U/C EI 90 U/C
Henco PE-Xc/AL/PE-Xc	75	6.0	two	E 120 U/C EI 90 U/C

* U/C pipe end configuration applies to C/C also

A.4.1.3 Aluminium composite pipes with PE-conduit insulation, perpendicular to the wall, with one Mulcol® Multicollar *Slim* pipe collars to both sides of the wall.

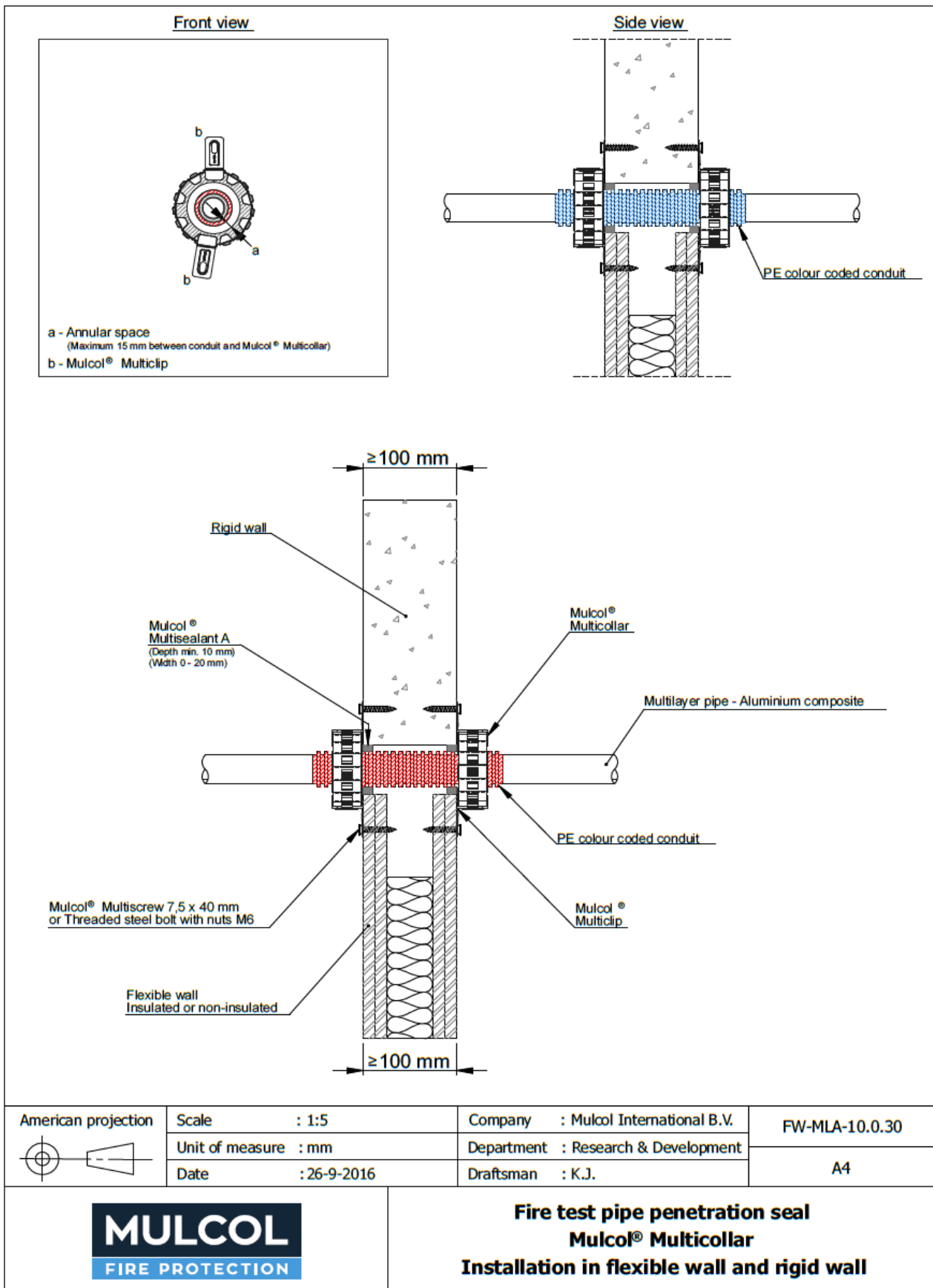

Pipe material [^]	Maximum pipe diameter mm	Pipe wall thickness mm	Conduit LS/CS/LI/CI diameter / length mm	No. of collars per face	Classification*
Henco PE-Xc/AL/PE-Xc pipes with PE conduit insulation	32	3.0	40 / 50 (min.)	One	EI 90 U/C

* U/C pipe end configuration applies to C/C also

A.4.1.4 Aluminium composite pipes insulated with PE-foam with a min. reaction to fire class CL-s1-d0 (to EN 13501-1), perpendicular to the wall, with two Mulcol® Multicollar Slim pipe collars to both sides of the wall

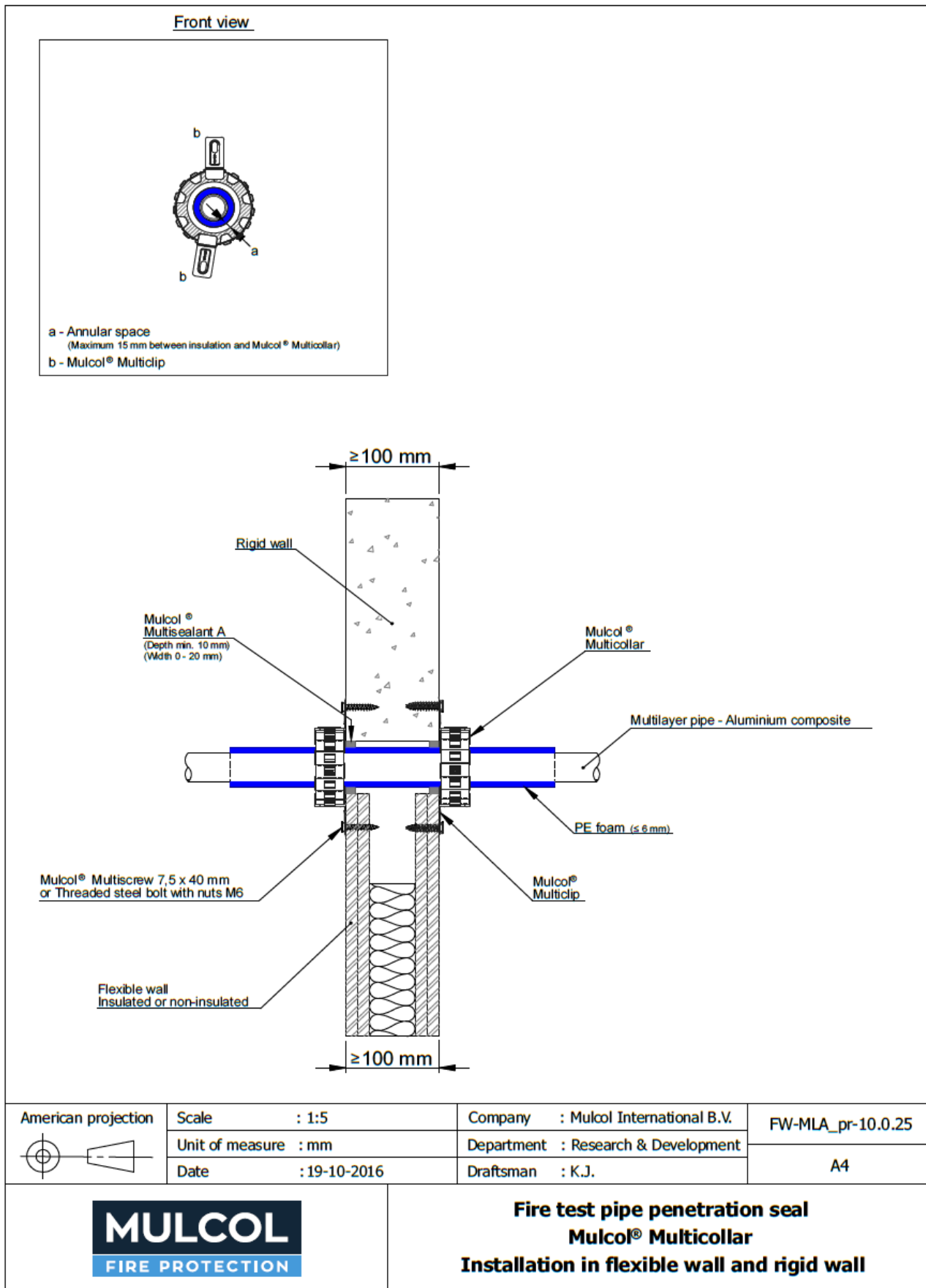

Pipe material [^]	Maximum pipe diameter mm	Pipe wall thickness mm	Insulation LS/CS/LI/CI thickness/length mm	No. of collars per face	Classification*
Henco PE-Xc/AL/PE-Xc	20	2.0	6 / 300 (min.)	One	EI 120 U/C
	26	3.0			
	32				

* U/C pipe end configuration applies to C/C also

A.4.1.5 Aluminium composite pipes insulated with AF/Armaflex made out of flexible elastomeric EPDM rubber foam with a min. reaction to fire class BL-s3, d0 or B-s3, d0 (to EN 13501-1), perpendicular to the wall, with two Mulcol® Multicollar *Slim* pipe collars to both sides of the wall

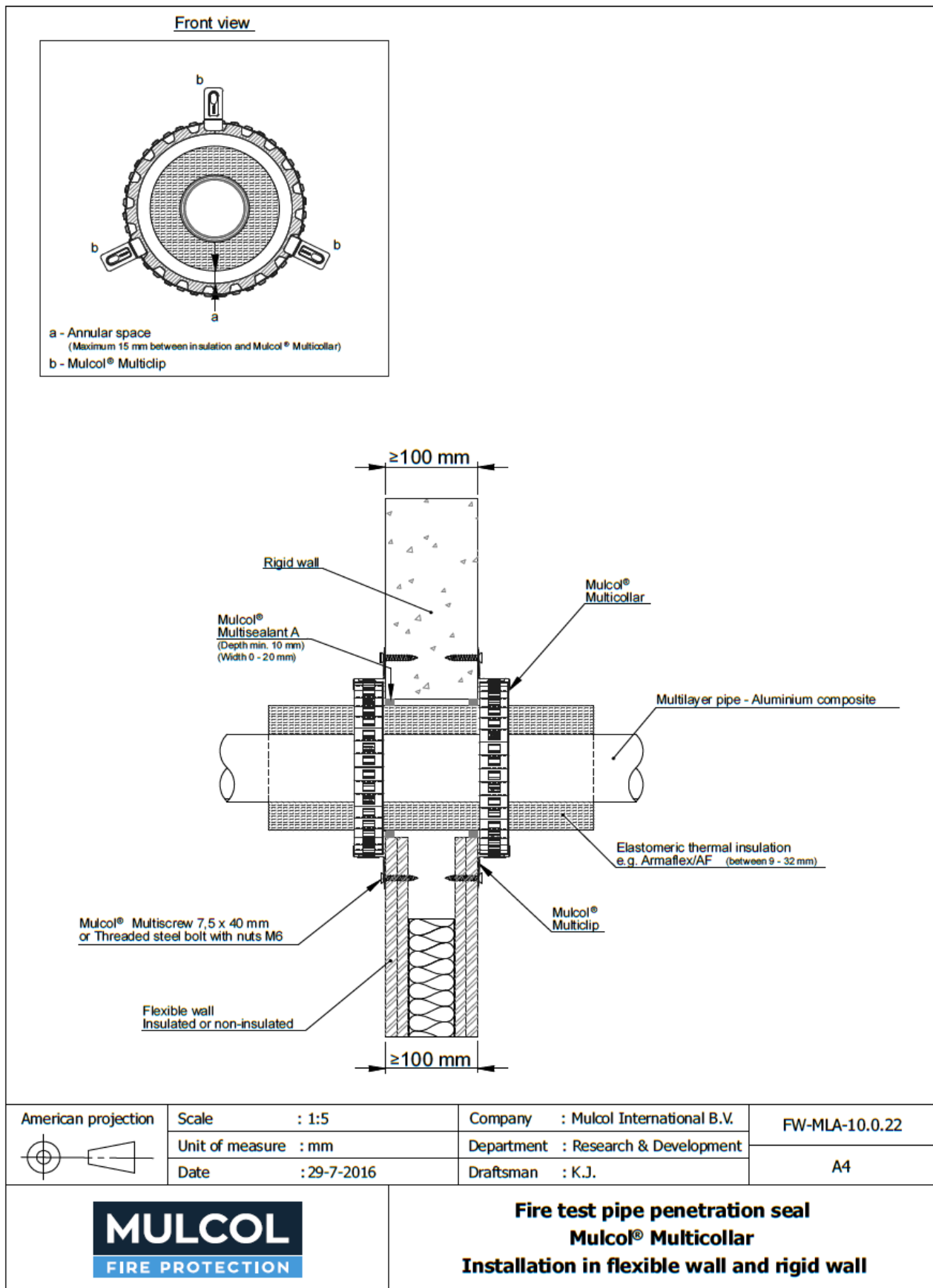

Pipe material [^]	Maximum pipe diameter mm	Pipe wall thickness mm	Insulation LS/CS/LI/CI thickness/ length mm	No. of collars per face	Classification*
Henco PE-Xc/AL/PE-Xc	20	2.0	9-32 / 500 (min.)	One	EI 120 U/C
	26	3.0			
	32				
	40	3.5			
	50	4.0			
	63	4.5			
	75	6.0	9 / 500 (min.)		
	90	7.0	9-32 / 500 (min.)		EI 90 U/C
	7.0				
Geberit Mepla PE-RT/AL/PE-RT	75	4.7	9 / 500 (min.)		E 120 U/C EI 90 U/C
Wavin Tigris PE-X/AL/PE		7.5	EI 120 U/C		
Alpex Duo PE-Xb/AL/PE-Xb	32	3.0	9-32 / 500 (min.)		EI 90 U/C
	63	4.5	32 / 500 (min.)	E 120 U/C EI 60 U/C E 120 U/C EI 90 U/C	
Uponor PE-RT/AL/PE-RT	40	4.0	9-32 / 500 (min.)	EI 120 U/C	
	110	10.0	32 / 500 (min.)	EI 90 U/C EI 120 U/C	

* U/C pipe end configuration applies to C/C also

A.4.1.6 Aluminium composite pipes insulated with AF/Armaflex made out of flexible elastomeric EPDM rubber foam with a min. reaction to fire class BL-s3, d0 or B-s3 or, d0 (to EN 13501-1), in Mulcol® Multimastic FB1 coated board seals, perpendicular to the wall, with one Mulcol® Multicollar Slim pipe collars to both sides of the wall

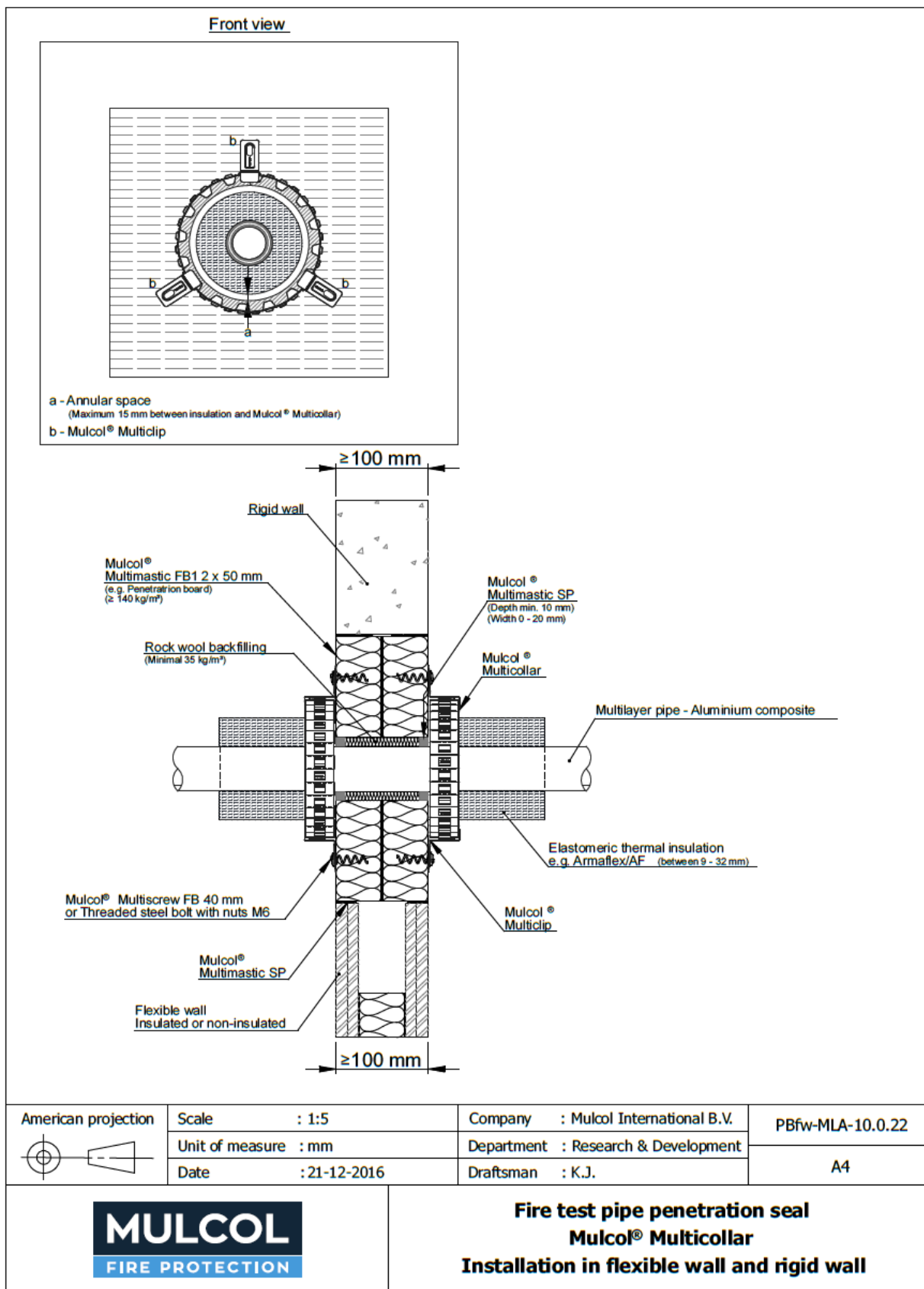

Pipe material [^]	Maximum pipe diameter mm	Pipe wall thickness mm	Insulation LI/CI thickness/ length mm	No. of collars per face	Classification*
Henco PE-Xc/AL/PE-Xc	50	4.0	9-32 / 300 (min.)	One	EI 120 U/C

* U/C pipe end configuration applies to C/C also

A.4.2 Aluminium composite pipes with zero distance to the floor

A.4.2.1 Aluminium composite pipes, perpendicular to the wall, with zero distance to the floor, with one Mulcol® Multicollar Slim pipe collars to both sides of the wall.

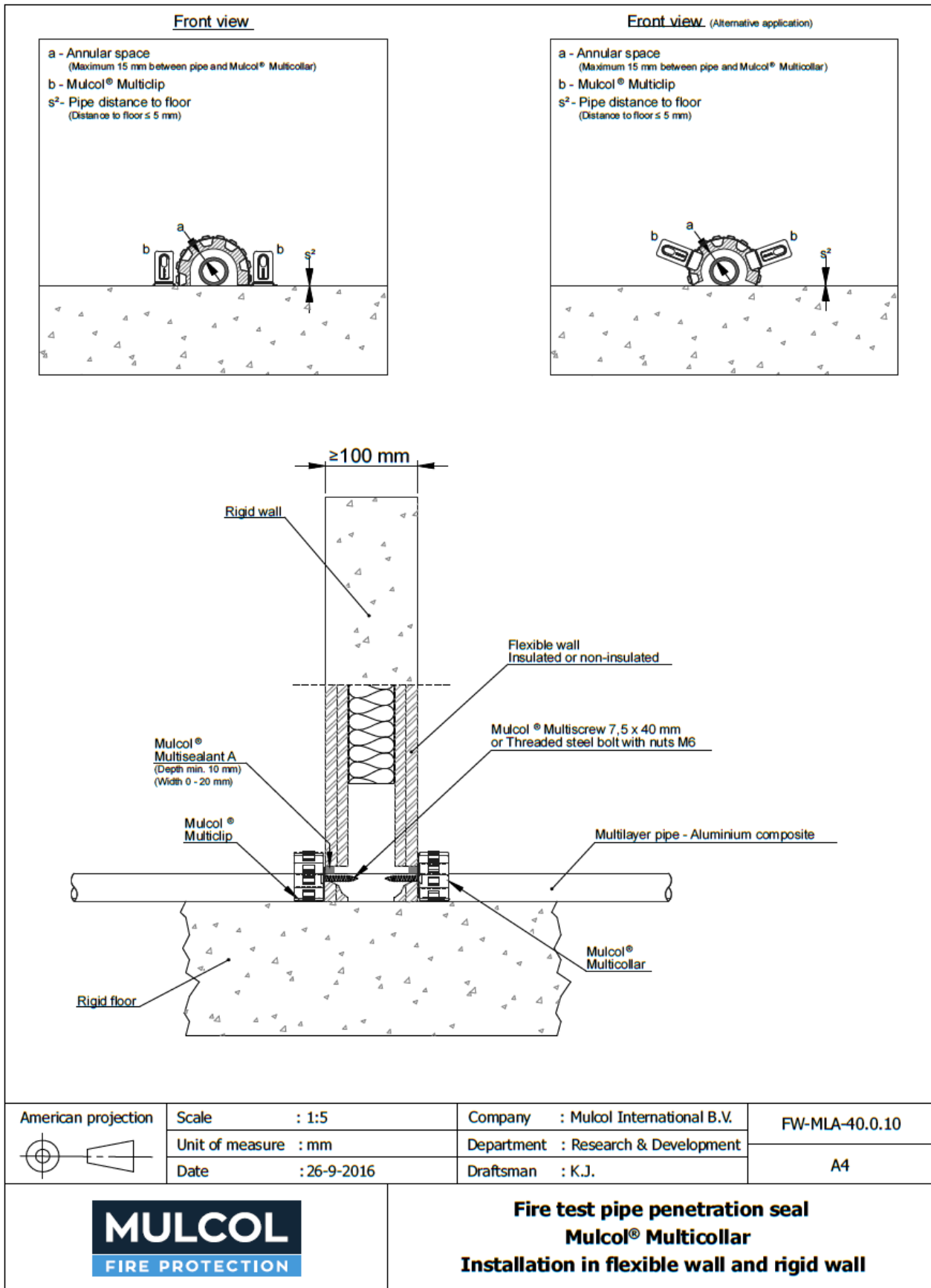

Pipe material [^]	Maximum pipe diameter mm	Pipe wall thickness mm	No. of collars per face	Classification*
Henco PE-Xc/AL/PE-Xc	32	3.0	one	EI 90 U/C

* U/C pipe end configuration applies to C/C also

[^] Pipes may optionally be fitted with up to 4 mm thick sound decoupling insulation, min. 50 mm long (LS/CS/LI/CI)

A.4.2.2 Aluminium composite pipes insulated with AF/Armaflex made out of flexible elastomeric EPDM rubber foam with a min. reaction to fire class BL-s3, d0 or B-s3 or, d0 (to EN 13501-1), perpendicular to the wall, with zero distance to the floor, with one Mulcol® Multicollar *Slim* pipe collars to both sides of the wall.

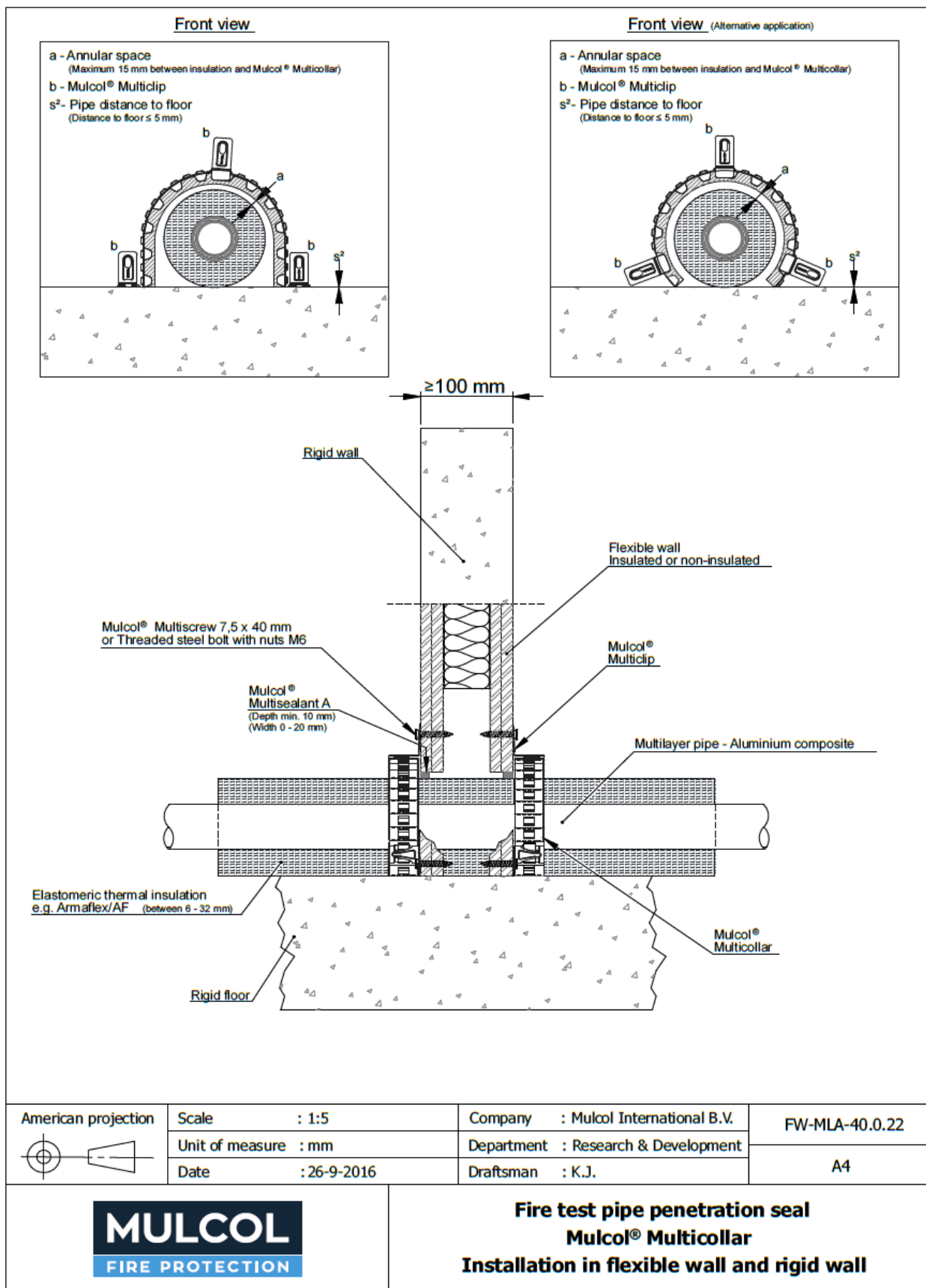

Pipe material	Maximum pipe diameter mm	Pipe wall thickness mm	Insulation LS/CS/LI/CI thickness/ length mm	No. of collars per face	Classification*
Henco PE-Xc/AL/PE-Xc	32	3.0	9-32 / 300 (min.)	One	EI 90 U/C
	50	4.0			

* U/C pipe end configuration applies to C/C also

A.4.2.3 2 x Aluminium composite pipes insulated with AF/Armaflex made out of flexible elastomeric EPDM rubber foam with a min. reaction to fire class BL-s3, d0 or B-s3 or, d0 (to EN 13501-1), perpendicular to the wall, with zero distance to the floor, with one Mulcol® Multicollar Slim pipe collars to both sides of the wall.

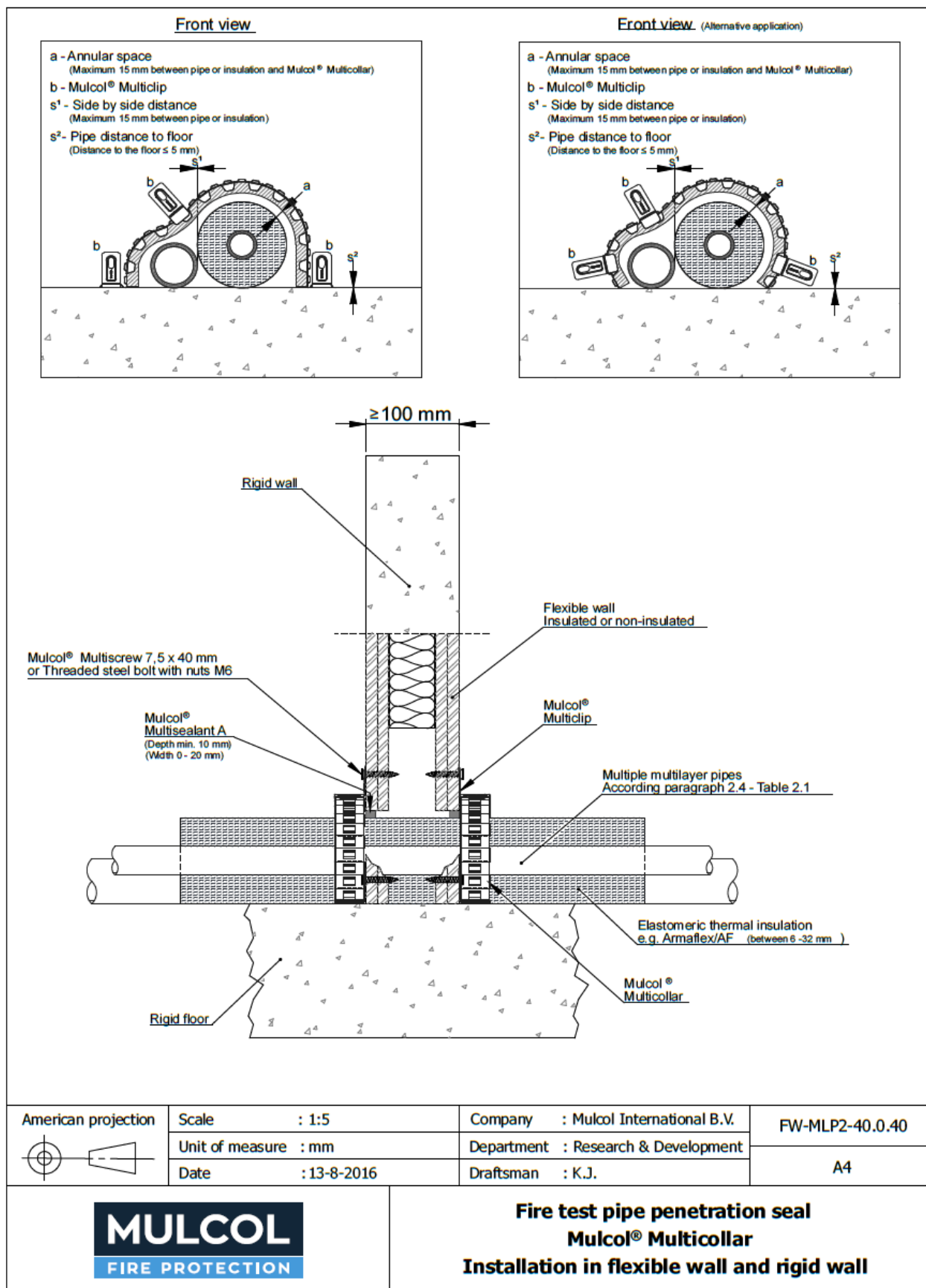

Pipe material	Maximum pipe diameter mm	Pipe wall thickness mm	Insulation LS/CS/LI/CI thickness/length mm	No. of collars per face	Classification*
Henco PE-Xc/AL/PE-Xc	32	3.0	9-32 / 300 (min.)	One	EI 90 U/C
	50	4.0	None		

* U/C pipe end configuration applies to C/C also

A.4.2.4 Up to 5 x Aluminium composite pipes insulated with PE foam with min. reaction to fire class CL-s1-d0 or AF/Armaflex made out of flexible elastomeric EPDM rubber foam with a min. reaction to fire class BL-s3, d0 or B-s3 or, d0 (to EN 13501-1) or PE conduit, perpendicular to the wall, with zero distance to the floor, with one Mulcol® Multicollar Slim pipe collars to both sides of the wall.

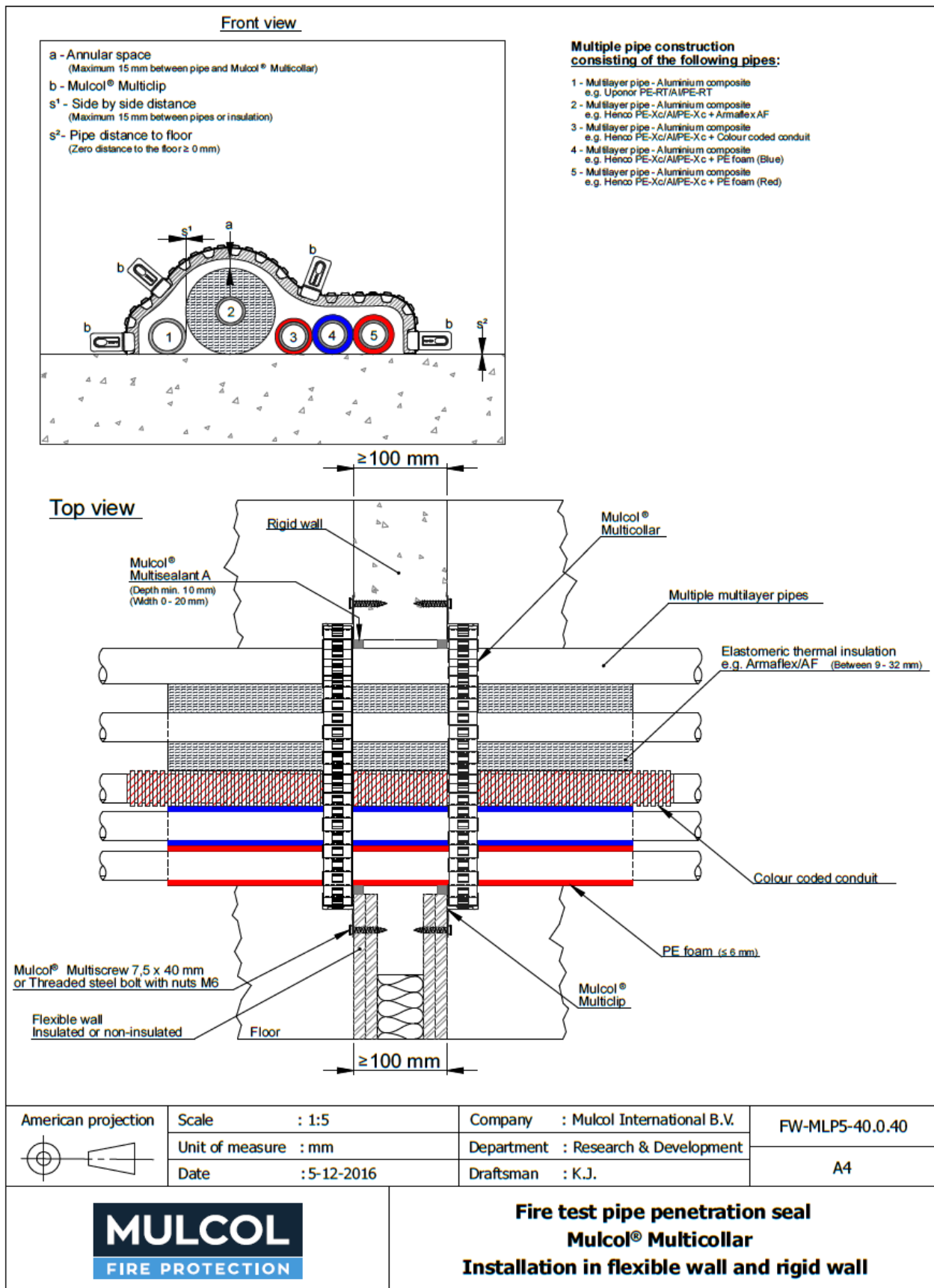

Pipe material	Maximum pipe diameter mm	Pipe wall thickness mm	Insulation LS/CS/LI/CI type / thickness/ length mm	No. of collars per face	Classification*
Uponor PE-RT/AL/PE-RT	40	4.0	None	One	EI 120 U/C
Henco PE-Xc/AL/PE-Xc	32	3.0	Armaflex AF / 9-32 / 300 (min.)		
			PE conduit / 4 / 300 (min.)		
			PE foam 6 / 300 (min.)		

* U/C pipe end configuration applies to C/C also

A.5 Multiple services in a single collar

A.5.1 Mixed pipes and cables in regular configurations

A.5.1.1 Up to 3 x mixed pipes and cables, perpendicular to the wall, with one Mulcol® Multicollar Slim pipe collars to both sides of the wall.

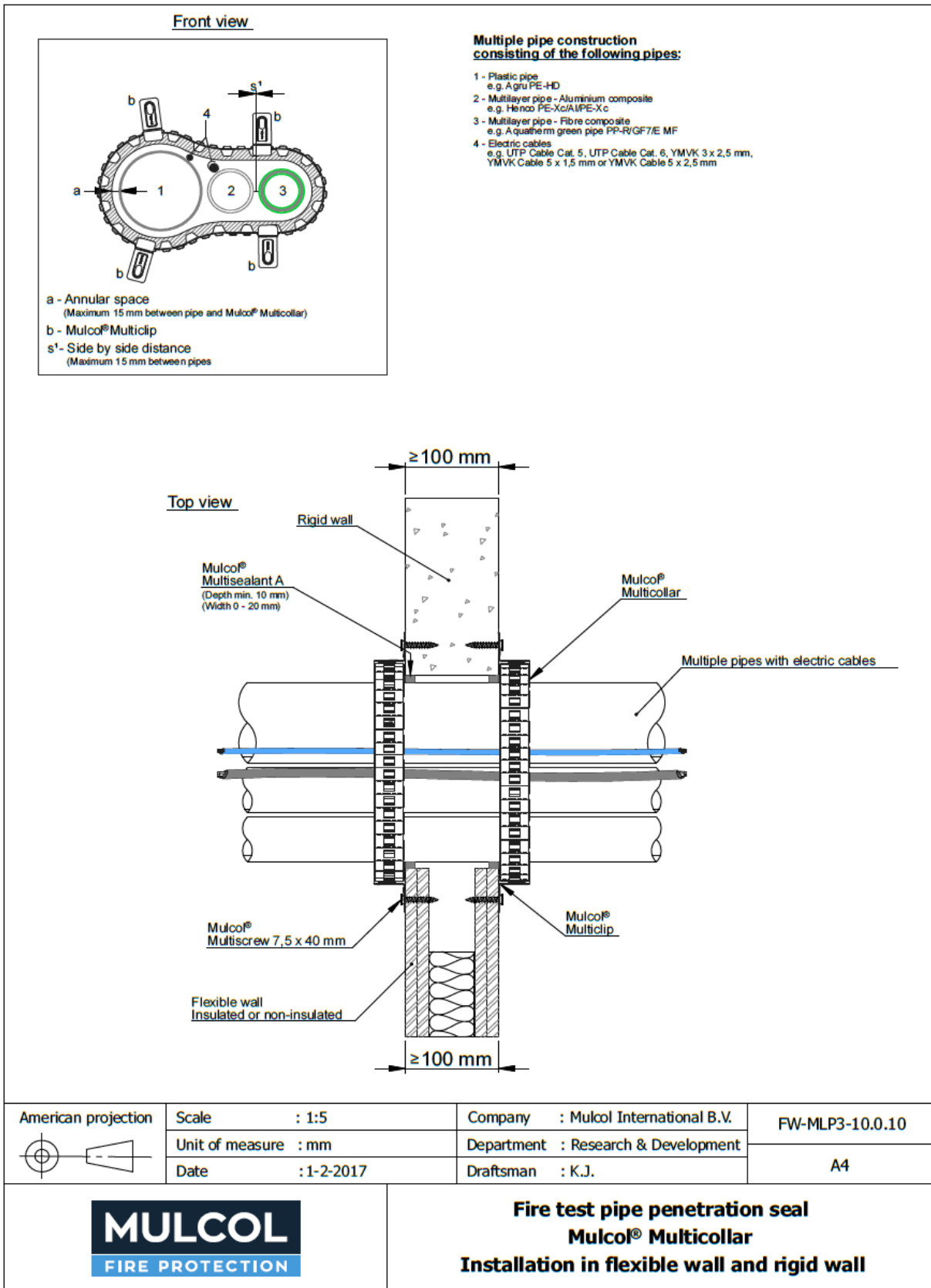

Pipe material / cable	Maximum pipe diameter mm	Pipe wall thickness mm	No. of collars per face	Classification*
PE-HD / PE / ABS / SAN+PVC	90	2.8	one	EI 120 U/U
Henco PE-Xc/AL/PE-Xc	50	4.0		E 120 U/C EI 90 U/C
Aquatherm Green-MF		6.9		EI 120 U/C
Telecom UTP Cat. 5 or Cat. 6	1 no.	NA		EI 120
Sheathed cable YMKV 3 x 2.5 mm ² , YMKV 5 x 1.5 mm ² or YMKV 5 x 2.5 mm ²	1 No.	NA		

* U/C pipe end configuration applies to C/C also

A.5.1.2 Up to 3 x mixed pipes and cables, with insulation of AF/Armaflex made out of flexible elastomeric EPDM rubber foam with a reaction to fire class BL-s3, d0 or B-s3, d0 (EN 13501-1), perpendicular to the wall, with one Mulcol® Multicollar Slim pipe collars to both sides of the wall.

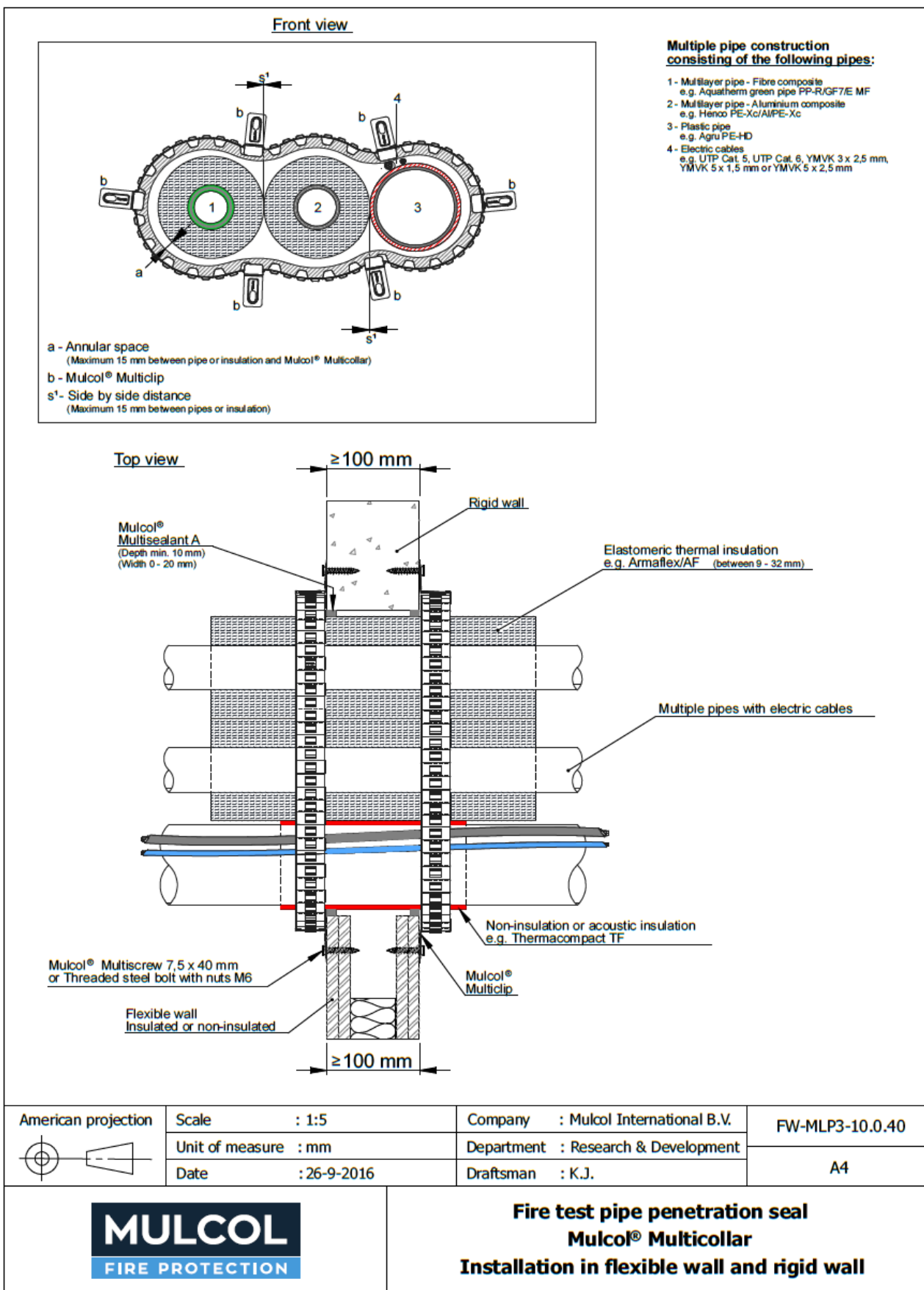

Pipe material / cable	Maximum pipe diameter mm	Pipe wall thickness mm	Insulation LS/CS/LI/CI Thickness / length mm	No. of collars per face	Classification*
PE-HD / PE / ABS / SAN+PVC	90	2.8	4 / 300 (min.)	One	EI 60 U/C
Henco PE-Xc/AL/PE-Xc	50	4.0	9-32 / 300 (min.)		
Aquatherm Green-MF		6.9			
Telecom UTP Cat. 5 or Cat. 6	1 no.	NA	None		EI 60
Sheathed cable YMKV 3 x 2.5 mm ² , YMKV 5 x 1.5 mm ² or YMKV 5 x 2.5 mm ²	1 No.	NA			

* U/C pipe end configuration applies to C/C also

A.5.1.3 Up to 3 x mixed pipes and cables, with insulation of PE foam with a reaction to fire class CL-s1-d0 (EN 13501-1), perpendicular to the wall, with one Mulcol® Multicollar Slim pipe collars to both sides of the wall.

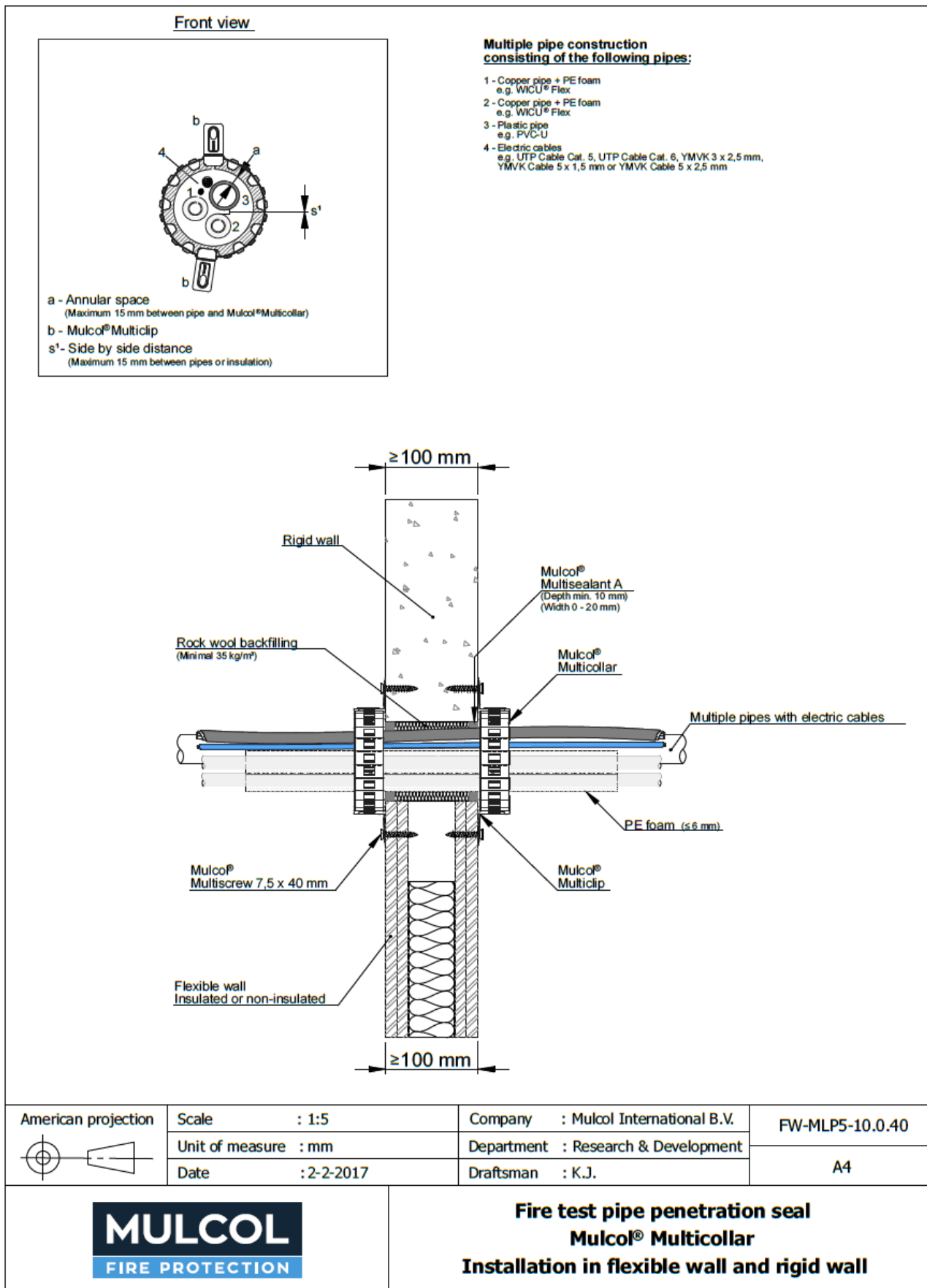

Pipe material / cable	Maximum pipe diameter mm	Pipe wall thickness mm	Insulation LS/CS/LI/CI Thickness / length mm	No. of collars per face	Classification*
Copper with insulation Wicu Flex PE-foam	15	1.5	6 / 300 (min.)	One	EI 60 C/U
PVC-U / PVC-C	32	3.0	None		EI 120 U/U
Telecom UTP Cat. 5 or Cat. 6	1 no.	NA	None		EI 120
Sheathed cable YMVK 3 x 2.5 mm ² , YMVK 5 x 1.5 mm ² or YMVK 5 x 2.5 mm ²	1 No.	NA			

* U/C pipe end configuration applies to C/C also

* U/U pipe end configuration applies to U/C, C/U and C/C also

A.5.2 Multiple pipes in regular configurations

A.5.2.1 Up to 3 x plastic pipes, perpendicular to the wall, with one Mulcol® Multicollar Slim pipe collars to both sides of the wall.

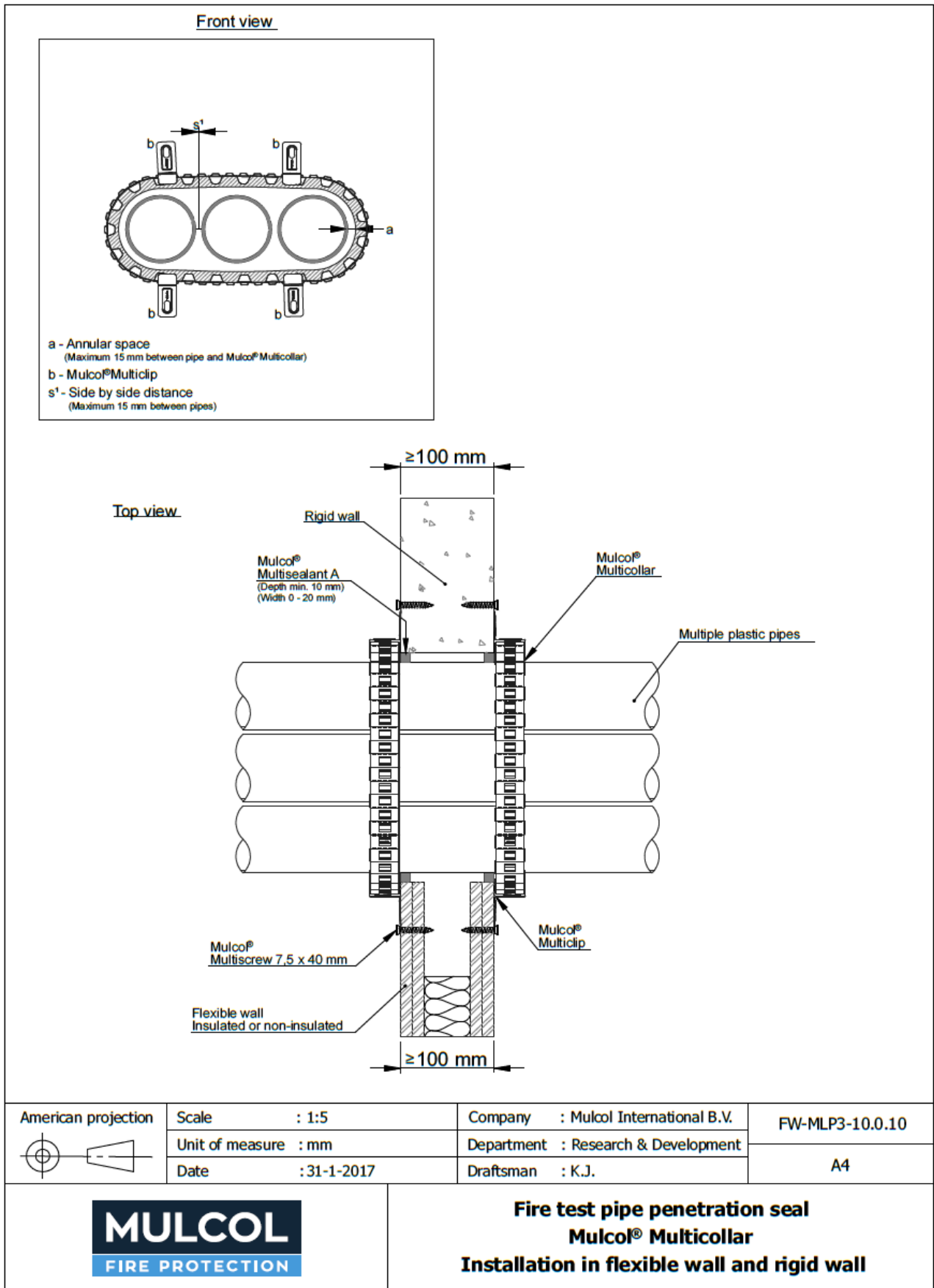

Pipe material / cable	Maximum pipe diameter mm	Pipe wall thickness mm	No. of collars per face	Classification*
PVC-U / PVC-C	75	3.0	One	E 120 U/C EI 90 U/C

* U/C pipe end configuration applies to C/C also

A.5.2.2 Up to 4 x Aluminium composite pipes, with insulation of PE foam with a reaction to fire class CL-s1-d0 (EN 13501-1), perpendicular to the wall, with one Mulcol® Multicollar Slim pipe collars to both sides of the wall.

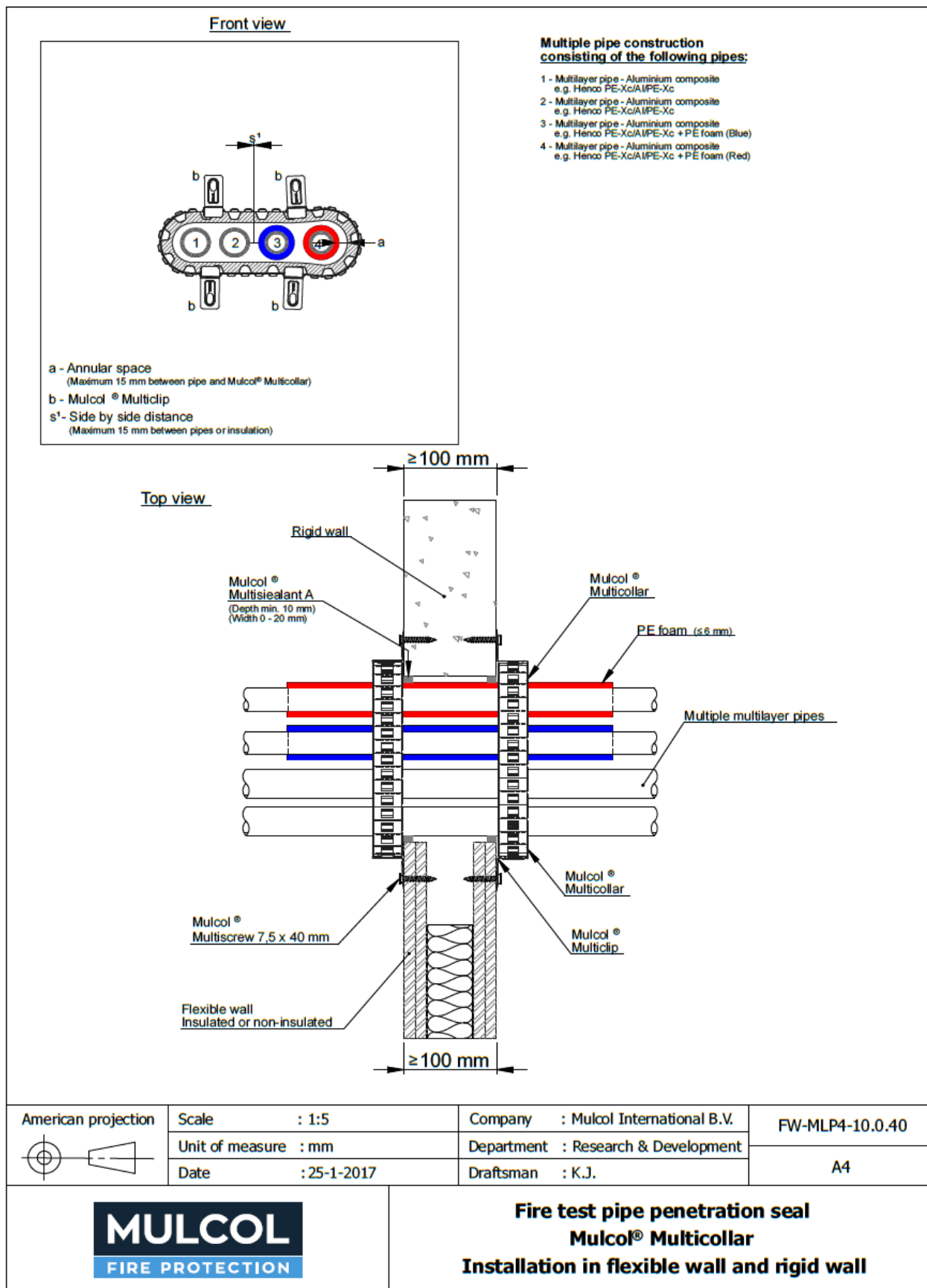

Pipe material / cable	Maximum pipe diameter mm	Pipe wall thickness mm	Insulation LS/CS/LI/CI Thickness / length mm	No. of collars per face	Classification*
Henco	26	3.0	6 / 300 (min.)	One	EI 120 U/C
PE-Xc/AL/PE-Xc	32		None		

* U/C pipe end configuration applies to C/C also

A.5.2.3 Up to 2 x Aluminium composite pipes with PE-foam insulation, min. reaction to fire class CL-s1-d0 (EN 13501-1) , perpendicular to the wall, in Mulcol® Multimastic FB1 coated board seals, with one Mulcol® Multicollar Slim pipe collar to both sides of the wall.

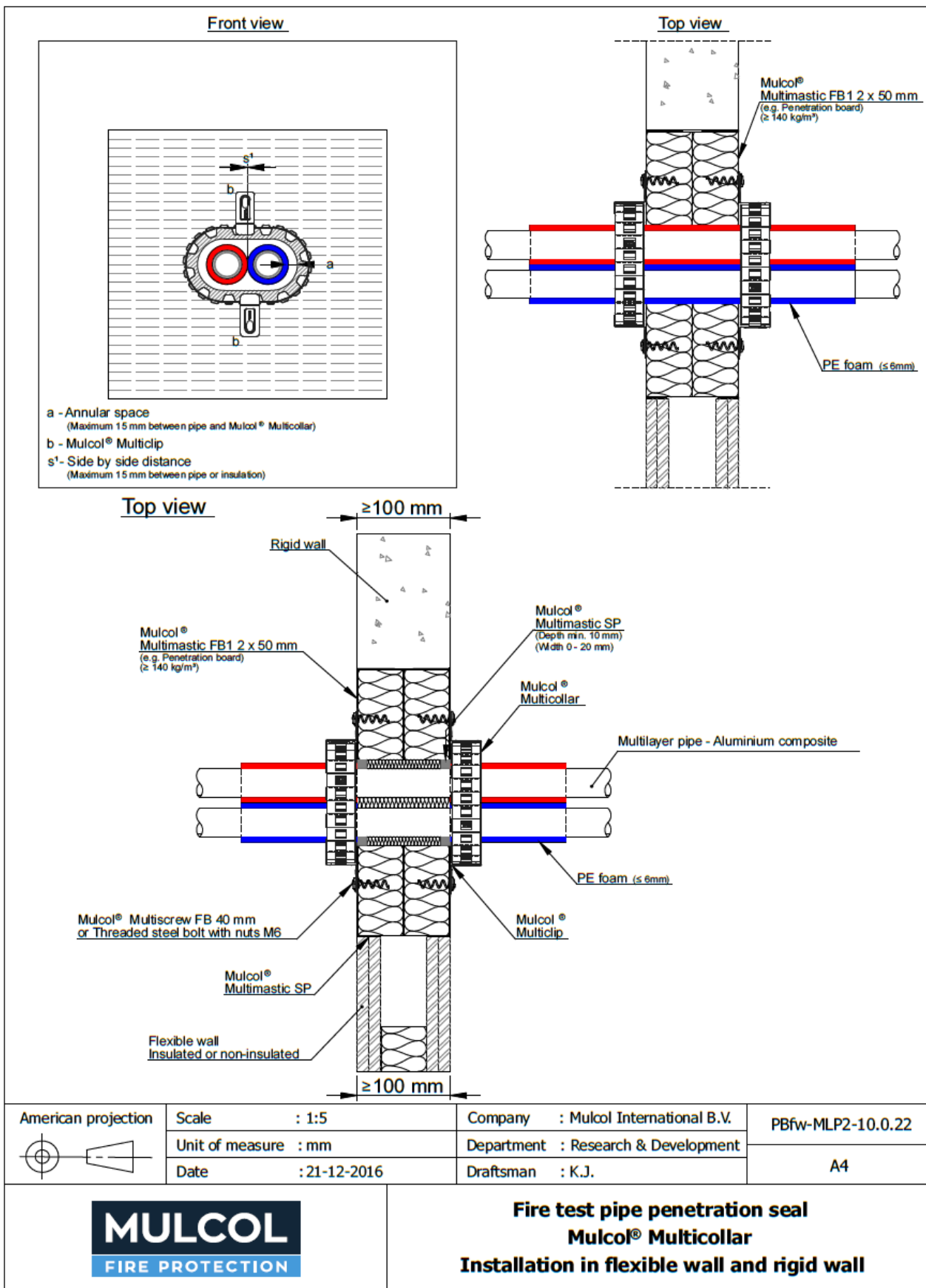

Pipe material	Maximum pipe diameter mm	Pipe wall thickness mm	Insulation LS/CS/LI/CI thickness / length mm	No. of collars per face	Classification*
Henco PE-Xc/AL/PE-Xc	32	3.0	6 / 300 (min.)	One	EI 120 U/C

* U/C pipe end configuration applies to C/C also

A.5.3 Multiple pipes with zero distance to the floor

A.5.3.1 Up to 5 x Aluminium composite pipes insulated with PE foam with min. reaction to fire class CL-s1-d0 or AF/Armaflex made out of flexible elastomeric EPDM rubber foam with a min. reaction to fire class BL-s3, d0 or B-s3 or, d0 (to EN 13501-1) or PE conduit, perpendicular to the wall, with zero distance to the floor, with one Mulcol® Multicollar Slim pipe collars to both sides of the wall.

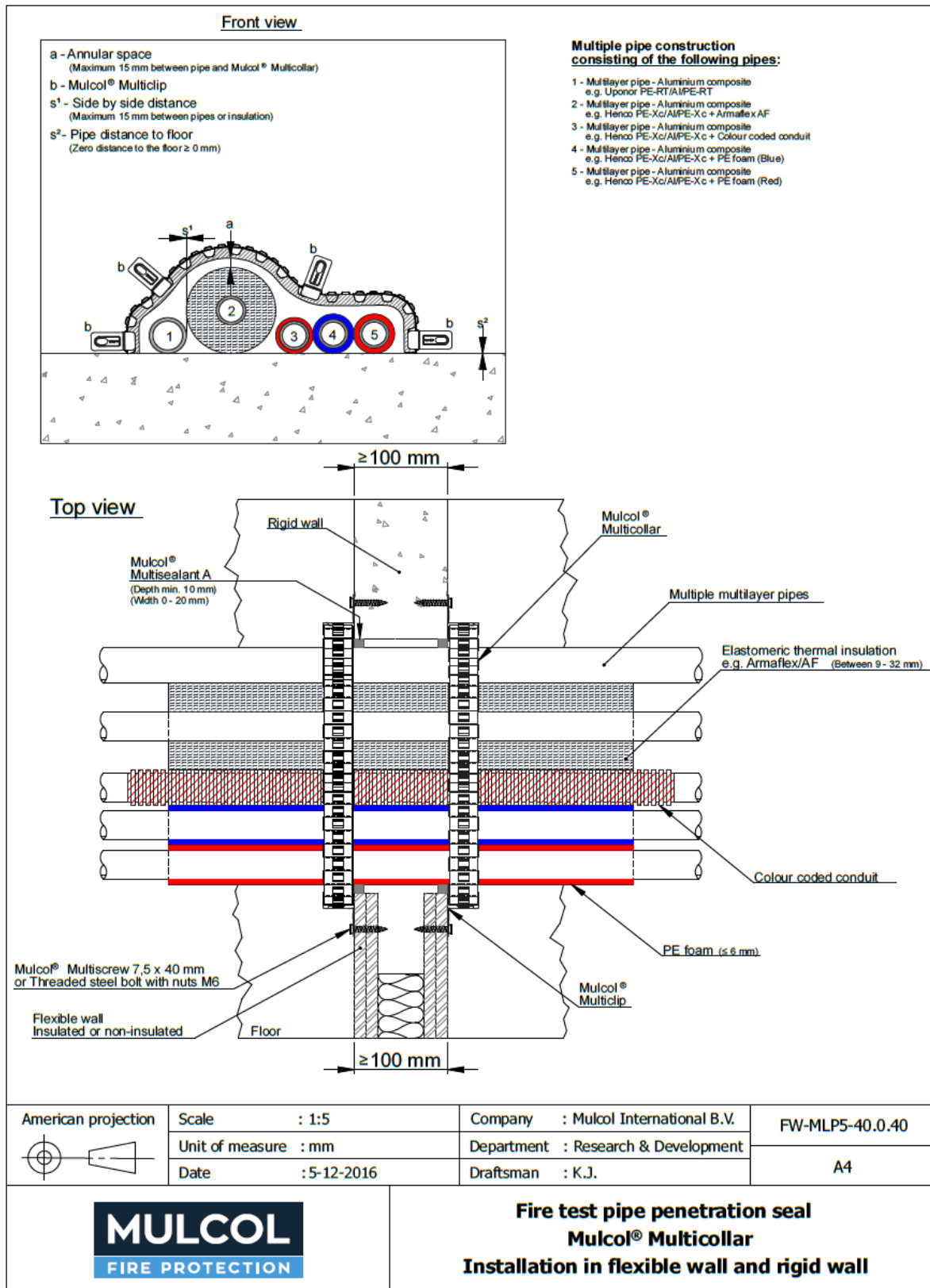

Pipe material	Maximum	Pipe wall	Insulation	No. of collars	Classification*
---------------	---------	-----------	------------	----------------	-----------------

	pipe diameter mm	thickness mm	LS/CS/LI/CI type / thickness/ length mm	per face	
Uponor PE-RT/AL/PE-RT	40	4.0	None	One	EI 120 U/C
Henco PE-Xc/AL/PE-Xc	32	3.0	Armaflex AF / 9-32 / 300 (min.)		
			PE conduit / 4 / 300 (min.)		
			PE foam 6 / 300 (min.)		

* U/C pipe end configuration applies to C/C also

A.5.3.2 2 x Aluminium composite pipes insulated with AF/Armaflex made out of flexible elastomeric EPDM rubber foam with a min. reaction to fire class BL-s3, d0 or B-s3 or, d0 (to EN 13501-1), perpendicular to the wall, with zero distance to the floor, with one Mulcol® Multicollar *Slim* pipe collars to both sides of the wall.

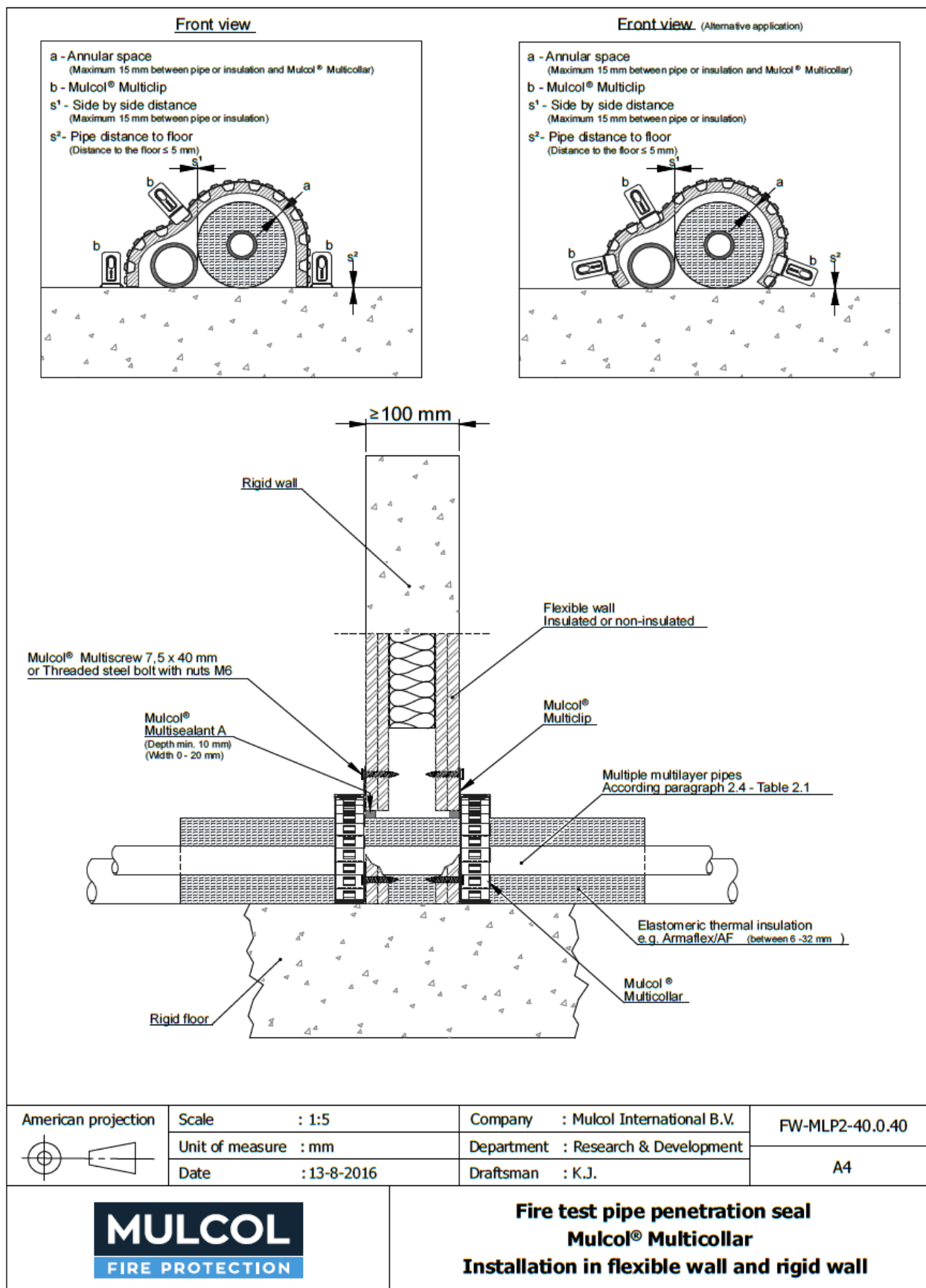

Pipe material	Maximum pipe diameter mm	Pipe wall thickness mm	Insulation LS/CS/LI/CI thickness/length mm	No. of collars per face	Classification*
Henco PE-Xc/AL/PE-Xc	32	3.0	9-32 / 300 (min.)	One	EI 90 U/C
	50	4.0	None		

* U/C pipe end configuration applies to C/C also

A.6 Flue Gas Pipes

A.6.1 Flue Gas Pipes in regular configurations

A.6.1.1 Aluminium flue gas pipes fitted perpendicular to the wall, with two Mulcol® Multicollar Slim pipe collars to the exposed (fire risk) side of the wall. This application shall only be used where the risk of fire in the building can be established as being from one side of the wall only.

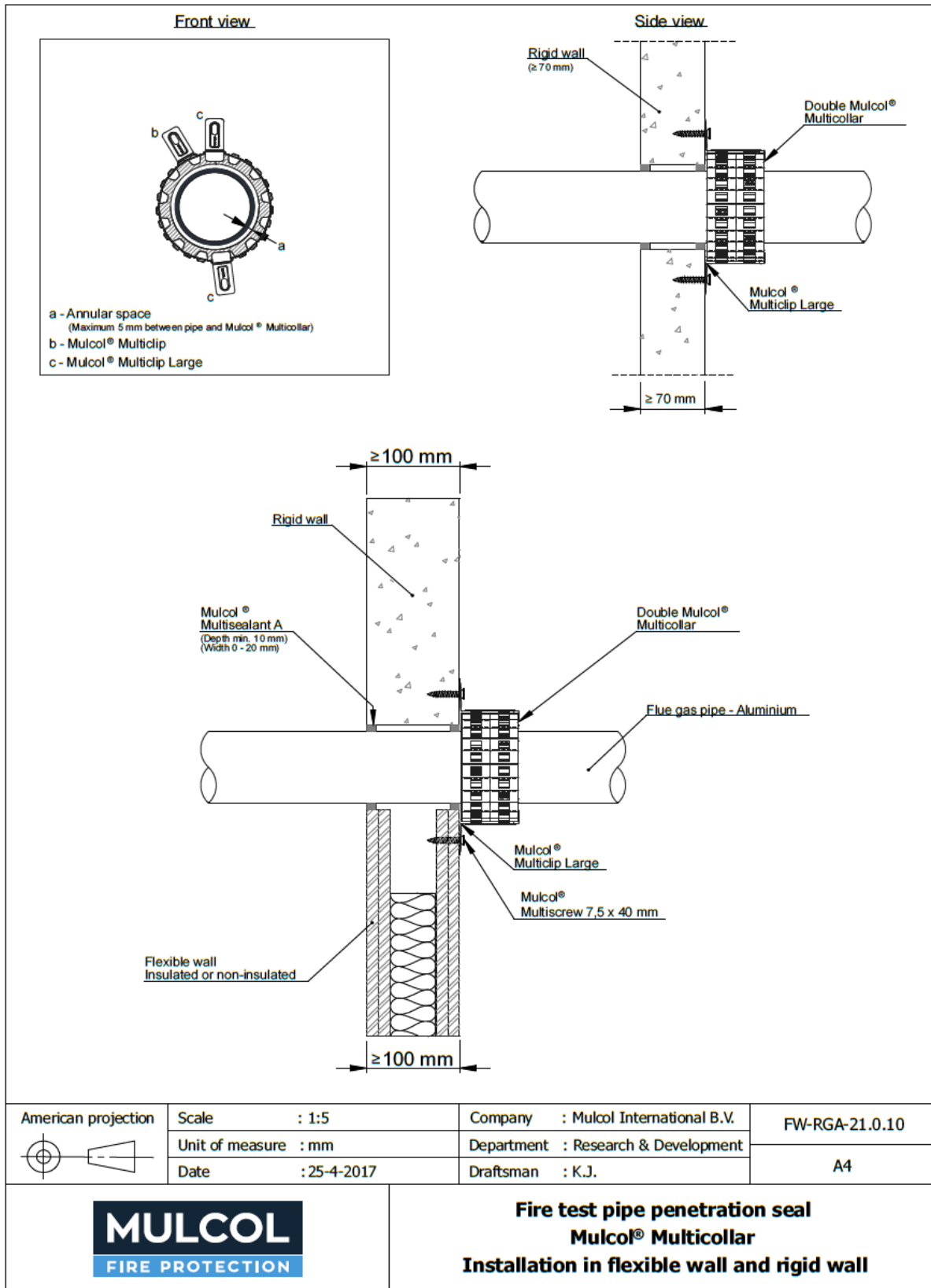

Pipe material	Maximum pipe diameter mm	Pipe wall thickness mm	No. of collars per face	Wall type and min. Thickness mm	Classification*
Aluminium	80	1.5	two	Rigid \geq 70 mm /flexible \geq 100 mm	E 90 U/C
	130				EI 15 U/C
					E 90 U/C

* U/C pipe end configuration applies to C/U and C/C also

A.6.1.2 Concentric steel flue gas pipes fitted perpendicular to the wall, with two Mulcol® Multicollar Slim pipe collars to the exposed (fire risk) side of the wall. This application shall only be used where the risk of fire in the building can be established as being from one side of the wall only.

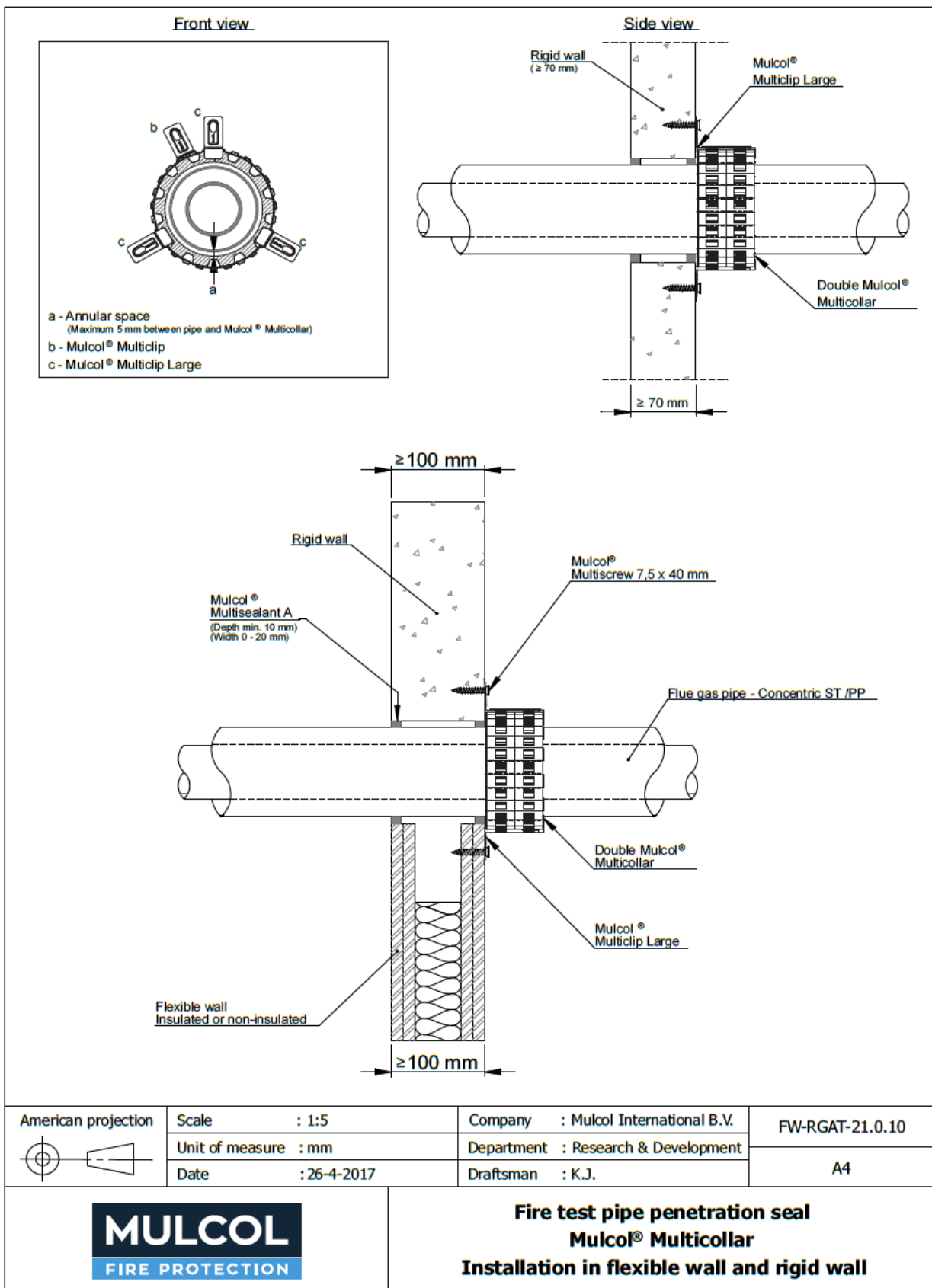

Pipe material	Outer Steel pipe diameter mm	Inner PP pipe diameter mm	No. of collars per face	Wall type and min. Thickness mm	Classification*
Steel flue gas system concentric	110	60	two	Rigid ≥ 70 mm / flexible ≥ 100 mm	E 90 U/C
	125	80			
	150	100			
	200	130			

* U/C pipe end configuration applies to C/U and C/C also

A.6.1.3 Plastic flue gas pipes fitted perpendicular to the wall, with one or two Mulcol® Multicollar Slim pipe collars to the exposed (fire risk) side of the wall. This application shall only be used where the risk of fire in the building can be established as being from one side of the wall only.

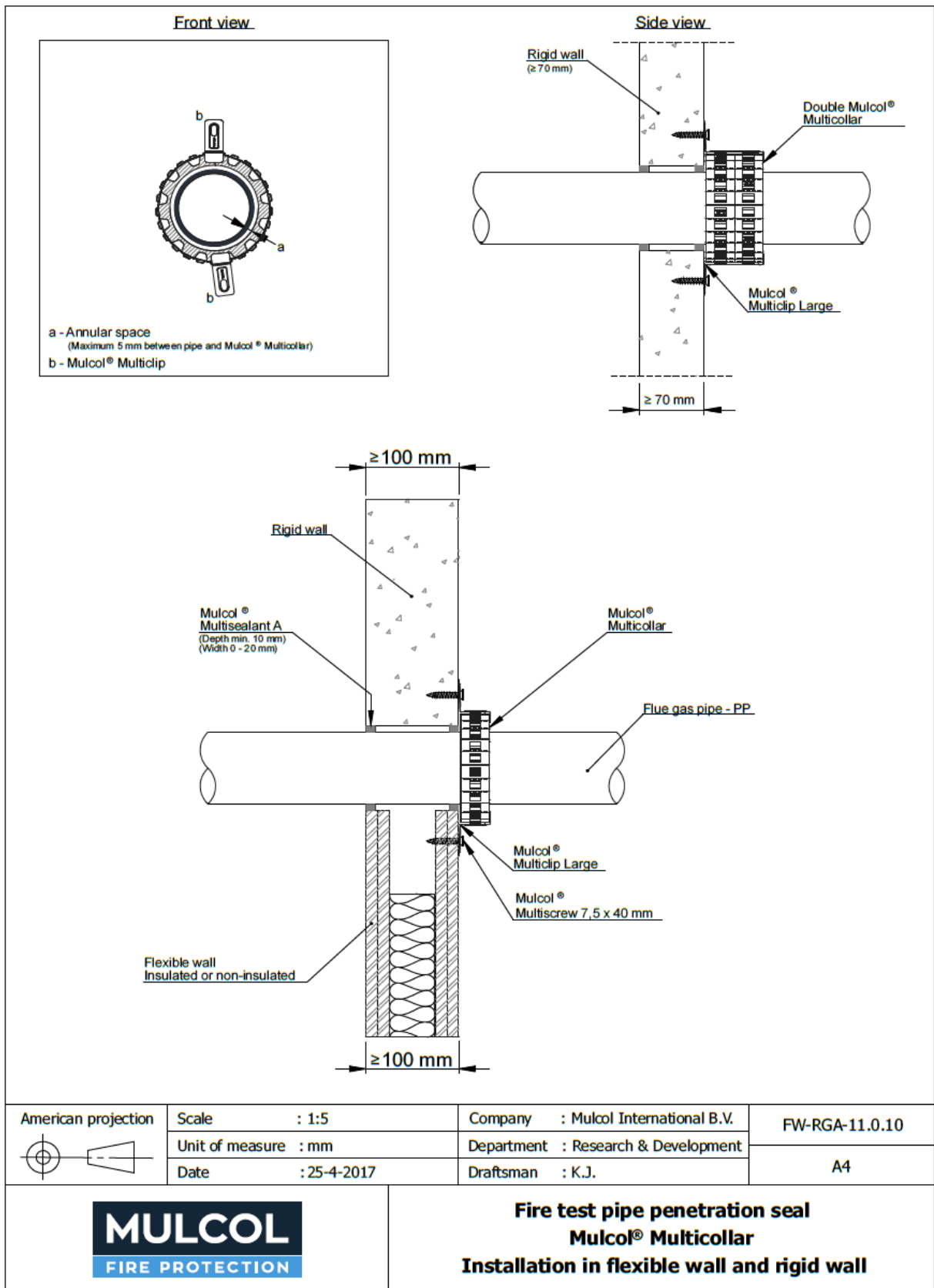

Pipe material	Maximum Pipe diameter mm	Pipe wall thickness mm	No. of collars per face	Wall type and min. Thickness mm	Classification*
PP	40	1.8-4.0	one	Rigid / flexible ≥ 100 mm	EI 90 U/U
	125	3.1-4.0			
	40	1.8-4.0	two	Rigid ≥ 70 mm	EI 60 U/U
	125	3.1-4.0			

* U/U pipe end configuration applies to U/C, C/U and C/C also

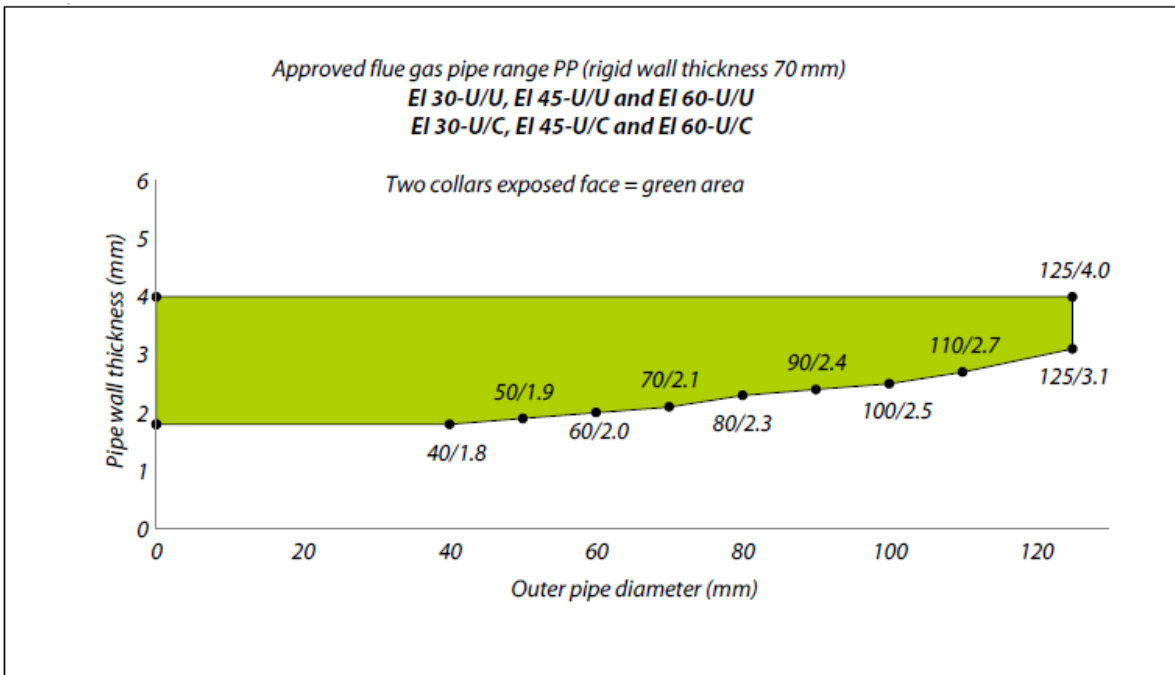
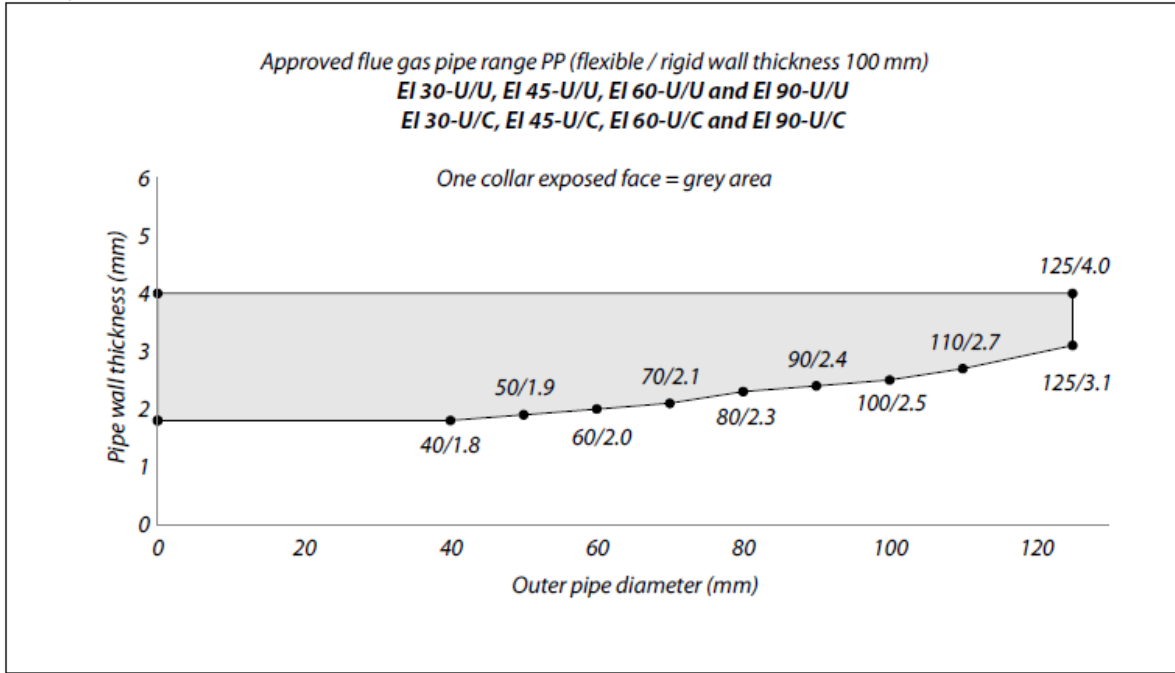

A.6.1.4 Concentric plastic flue gas pipes fitted perpendicular to the wall, with one or two Mulcol® Multicollar Slim pipe collars to the exposed (fire risk) side of the wall. This application shall only be used where the risk of fire in the building can be established as being from one side of the wall only.

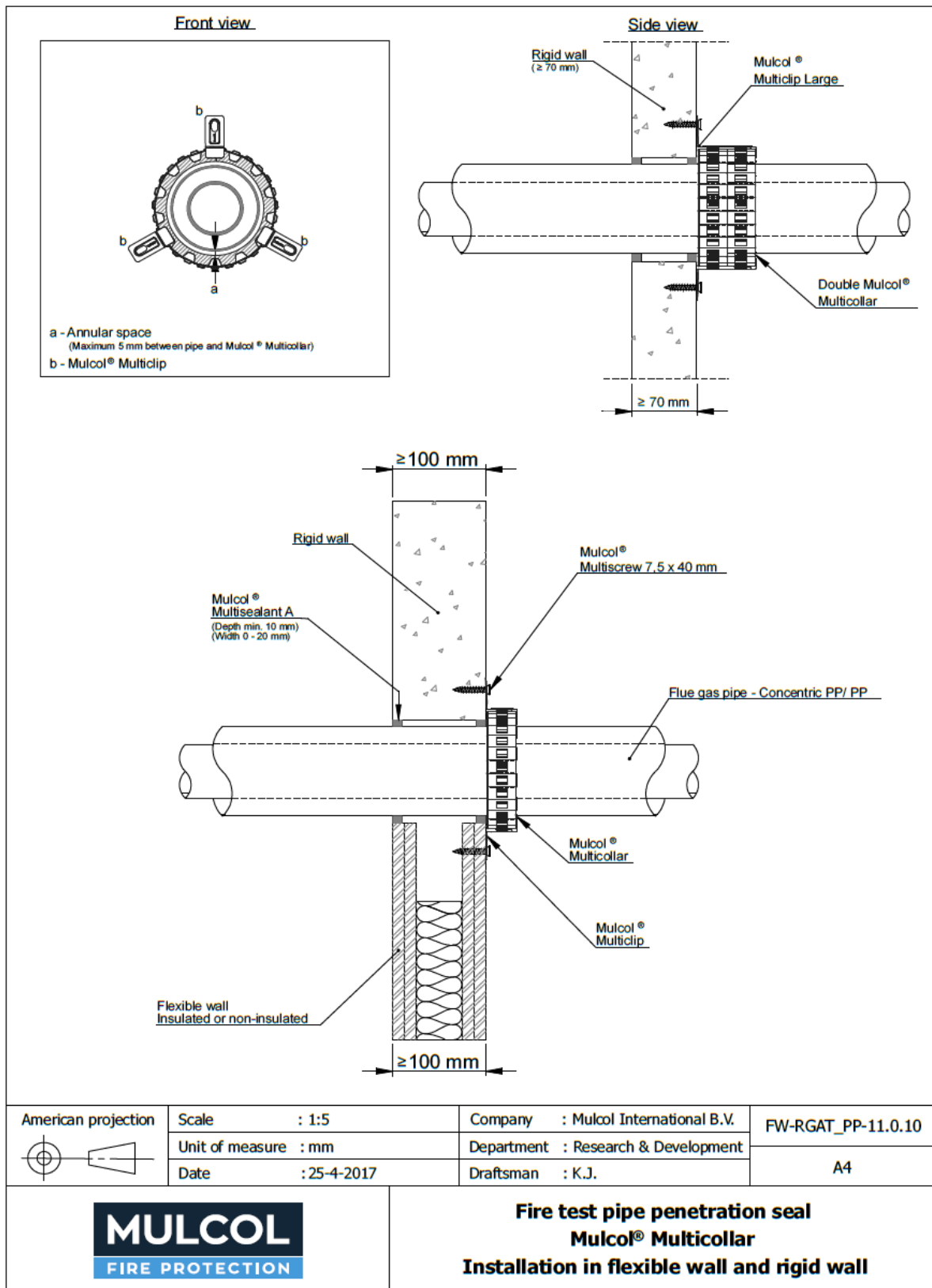

Pipe material	Maximum	Pipe wall	No. of	Wall type and	Classification*
---------------	---------	-----------	--------	---------------	-----------------

	Pipe diameter mm	thickness mm	collars per face	min. Thickness mm	
PP/PP	40	1.8-4.0	one	Rigid / flexible ≥ 100 mm	EI 90 U/U
	125	3.1-4.0			
	40	1.8-4.0	two	Rigid ≥ 70 mm	EI 60 U/U
	125	3.1-4.0			

* U/U pipe end configuration applies to U/C, C/U and C/C also

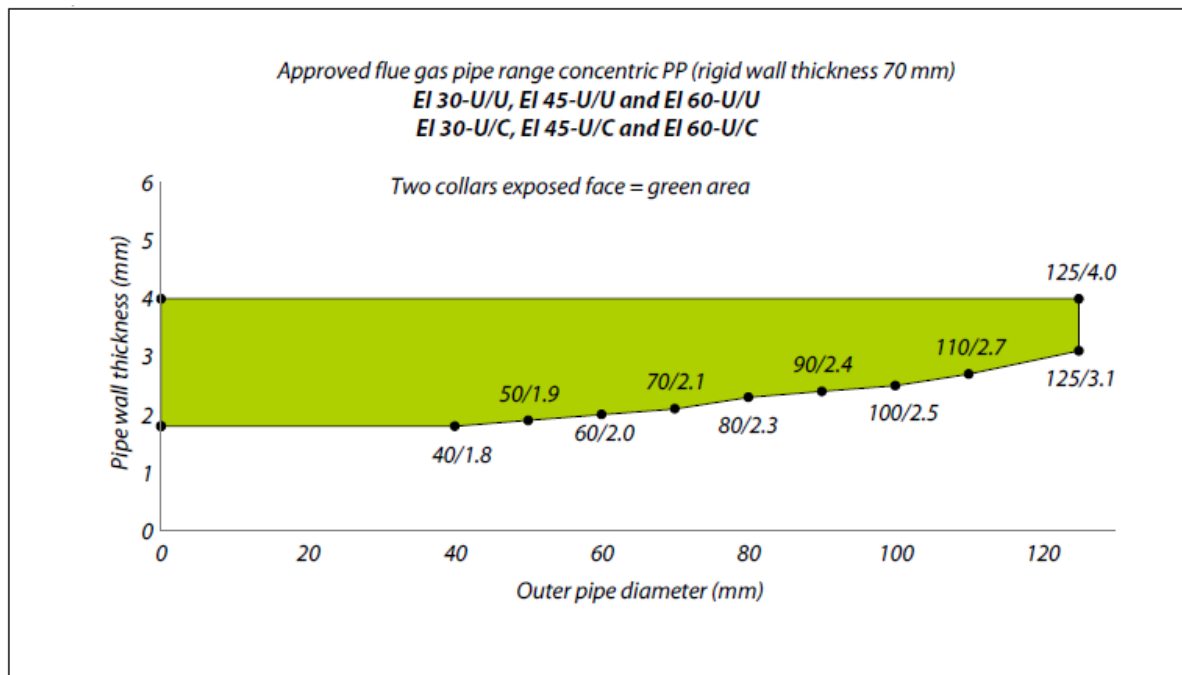
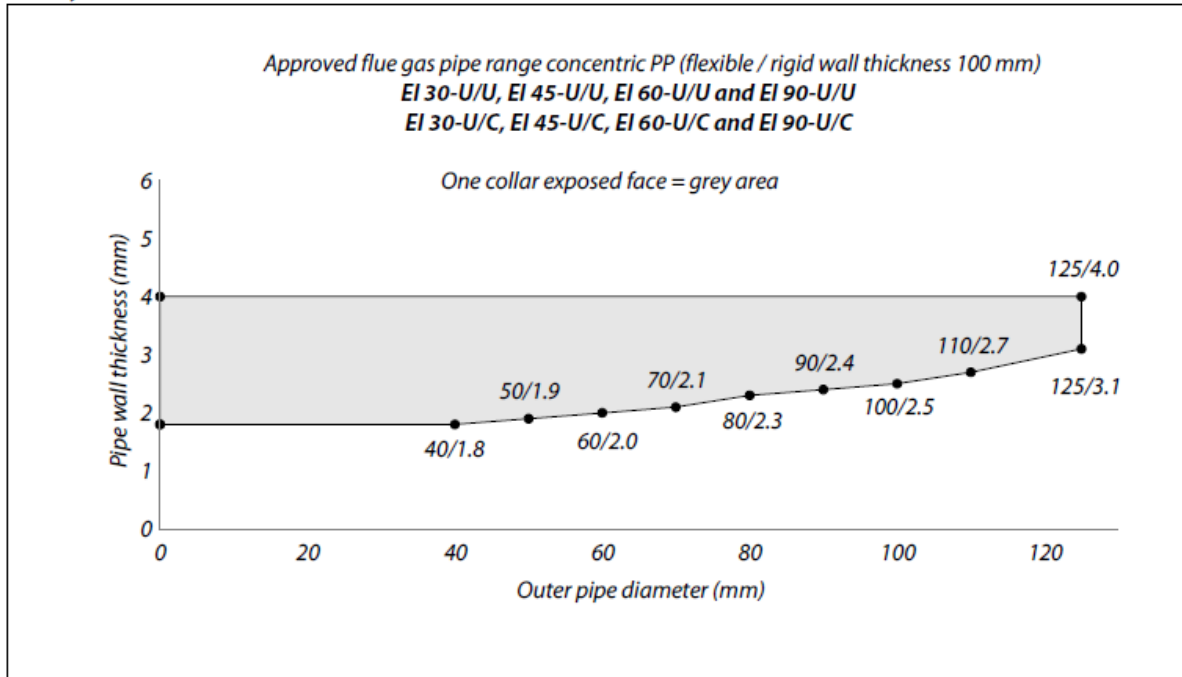

A.7 Electrical cables

A.7.1 Electrical cables in regular configurations

A.7.1.1 PVC pipes containing electrical cables, fitted perpendicular to the wall, with one Mulcol® Multicollar Slim pipe collars to both sides of the wall

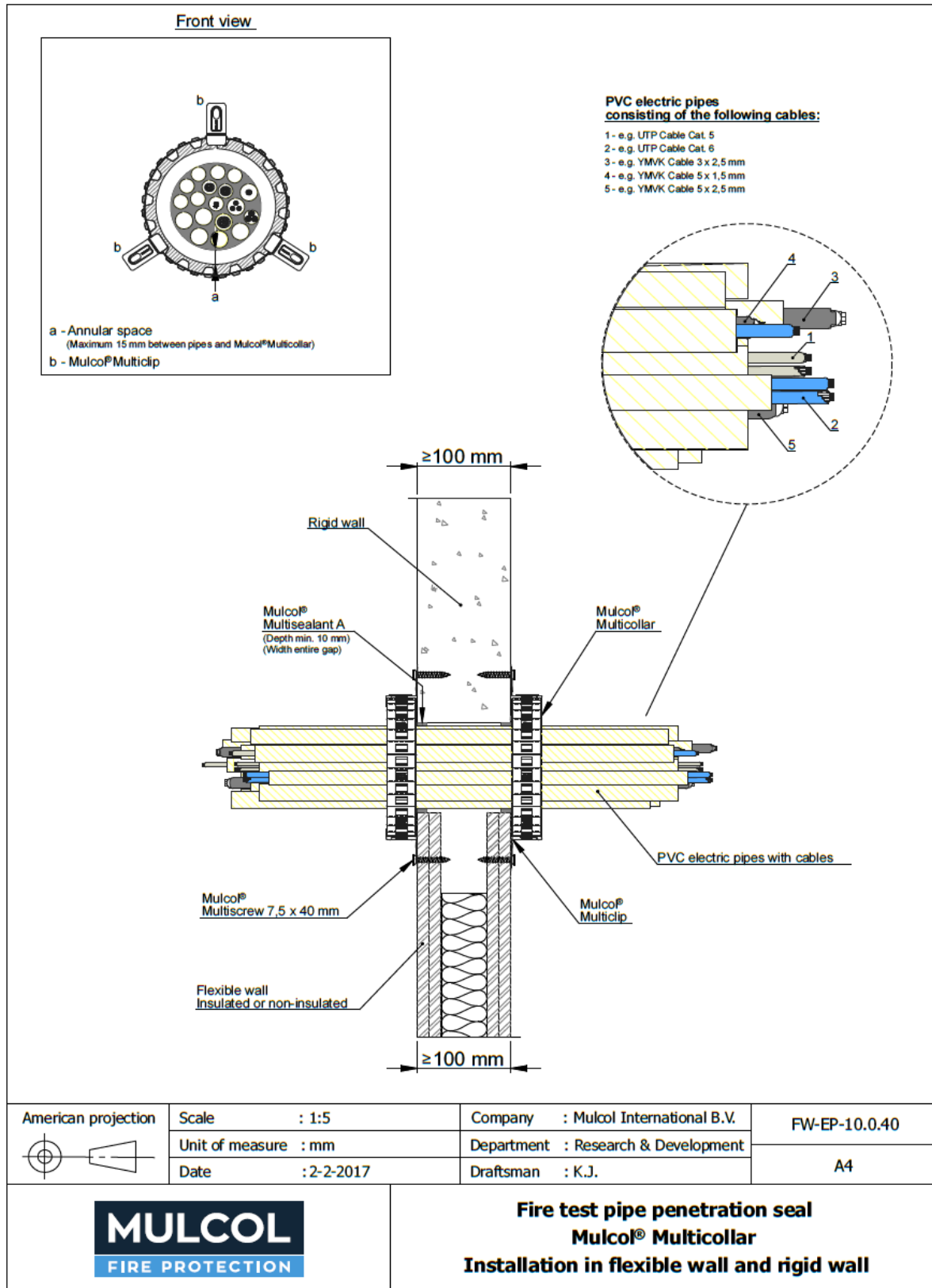

Pipe material /	Maximum	Maximum	Permitted cables	No. of collars	Classification*
-----------------	---------	---------	------------------	----------------	-----------------

max. number	pipe diameter mm	aperture diameter mm	(empty to full fill)	per face	
PVC / 18	25	100	Telecommunication cables UTP Cat. 5	One	EI 90 U/U
			Telecommunication cables UTP Cat. 6		
			Sheathed cable YMKV 3 x 2.5 mm ²		
			Sheathed cable YMKV 5 x 1.5 mm ²		
			Sheathed cable YMKV 5 x 2.5 mm ²		

* U/U pipe end configuration applies to U/C, C/U and C/C also

A.7.1.2 Electrical cables, fitted perpendicular to the wall, with one Mulcol® Multicollar Slim pipe collars to both sides of the wall.

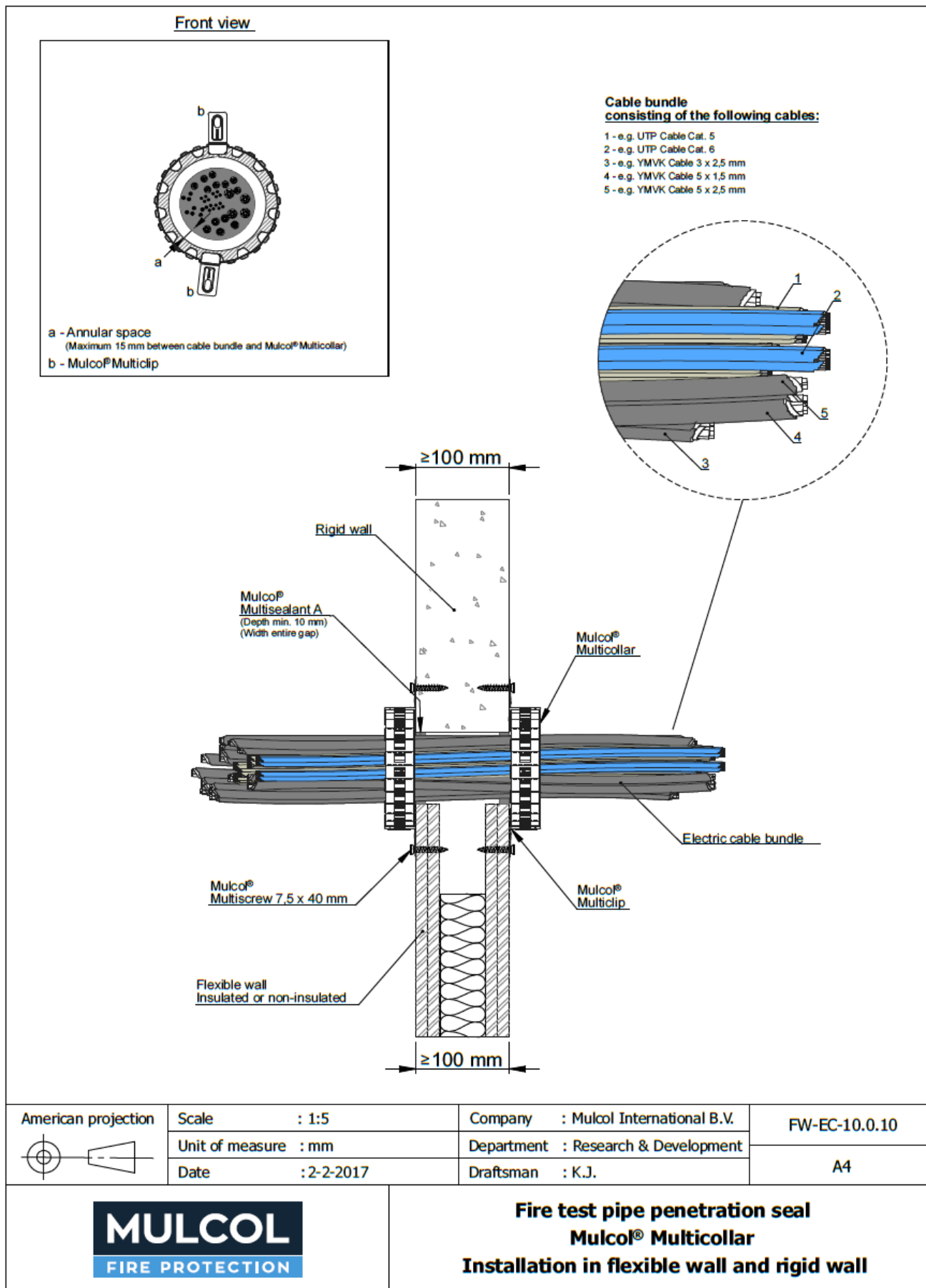

Max. Number	Maximum aperture diameter mm	Permitted cables (empty to full fill)	No. of collars per face	Classification*
63	100	Telecommunication cables UTP Cat. 5	One	EI 120
		Telecommunication cables UTP Cat. 6		
		Sheathed cable YMVK 3 x 2.5 mm ²		
		Sheathed cable YMVK 5 x 1.5 mm ²		
		Sheathed cable YMVK 5 x 2.5 mm ²		

A.7.1.3 PE conduits containing electrical cables, fitted perpendicular to the wall, with one Mulcol® Multicollar *Slim* pipe collars to both sides of the wall.

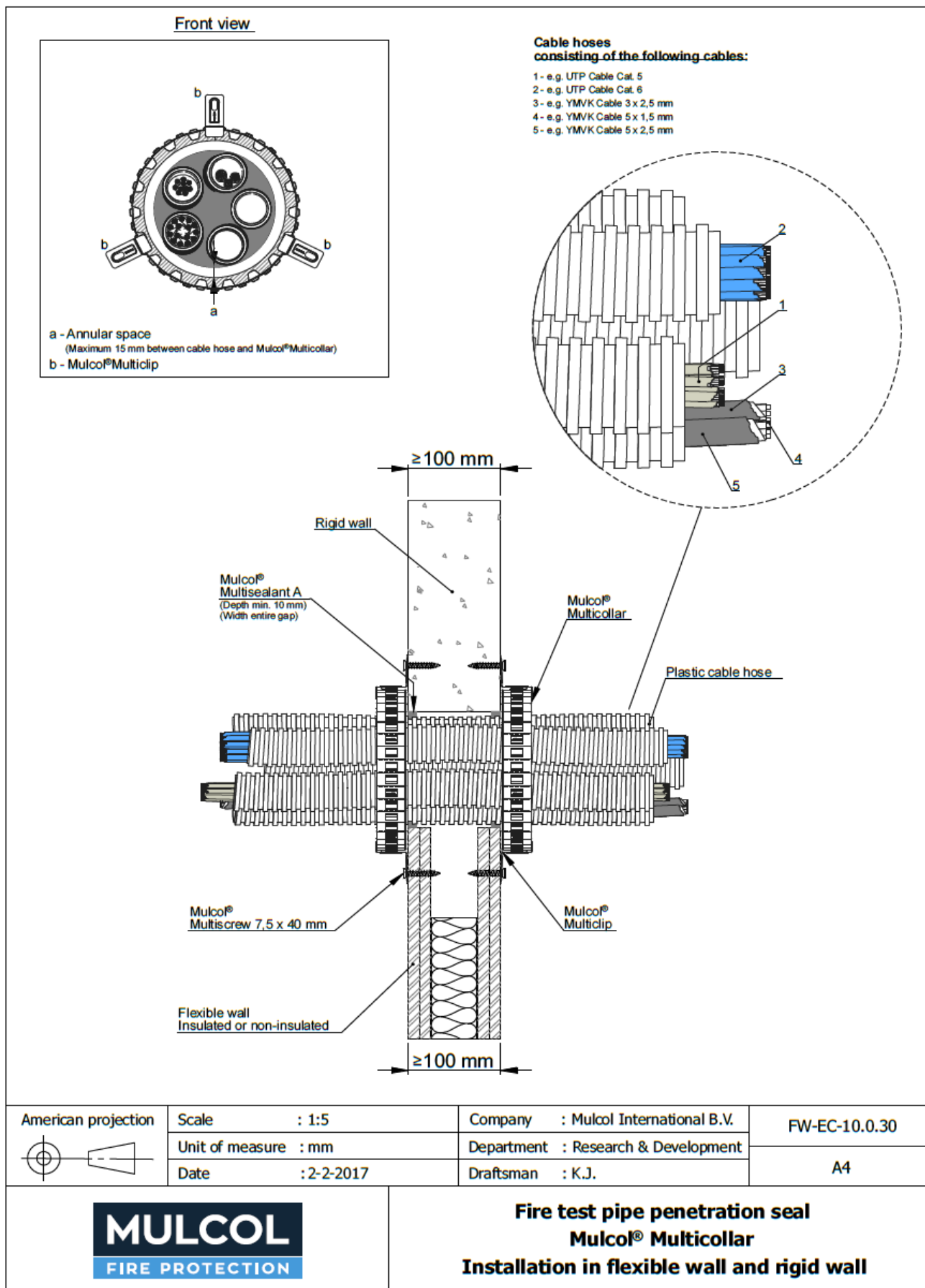

Pipe material / max. number	Maximum pipe diameter mm	Maximum aperture diameter mm	Permitted cables (empty to full fill)	No. of collars per face	Classification*
PE / 5	50	150	Telecommunication cables UTP Cat. 5	One	EI 120 U/U
			Telecommunication cables UTP Cat. 6		
			Sheathed cable YMVK 3 x 2.5 mm ²		
			Sheathed cable YMVK 5 x 1.5 mm ²		
			Sheathed cable YMVK 5 x 2.5 mm ²		

* U/U pipe end configuration applies to U/C, C/U and C/C also

A.8 Metal pipes

A.8.1 Metal pipes in regular configurations

A.8.1.1 Metal pipes insulated with AF/Armaflex made out of flexible elastomeric EPDM rubber foam with min. reaction to fire class BL-s3, d0 or B-s3, d0 (EN 13501-1), fitted perpendicular to the wall, with one Mulcol® Multicollar Slim pipe collars to both sides of the wall.

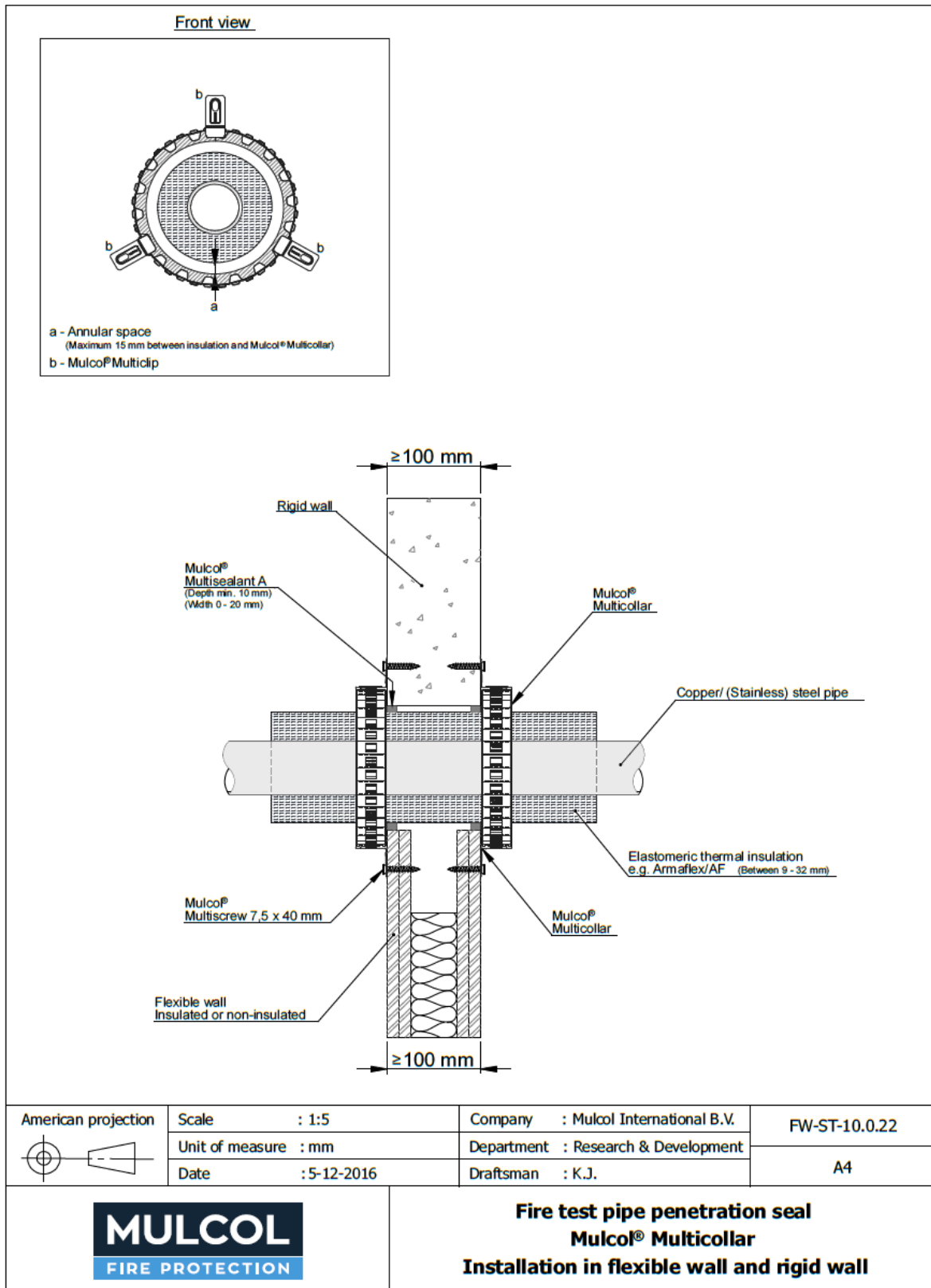

Pipe material	Maximum Pipe diameter mm	Pipe wall thickness mm	Insulation LS/CS thickness / length mm	No. of collars per face	Classification*
Copper / Steel / Iron / Stainless Steel	54	1.5-14.2	9-32 / 500 (min.)	One	E 120 C/U EI 60 C/U
			32 / 500 (min.)		E 120 C/U EI 90 C/U
	88.9	2.0-14.2	9-32 / 500 (min.)		E 120 C/U EI 45 C/U
			9-32 / Continuous (CS)		E 120 C/U EI 60 C/U
	219.1	4.0-14.2	9-32 / 500 (min.)		E 120-C/U EI 60-C/U
			9-32 / Continuous (CS)		E 120 C/U EI 90 C/U

* C/U pipe end configuration applies to C/C also

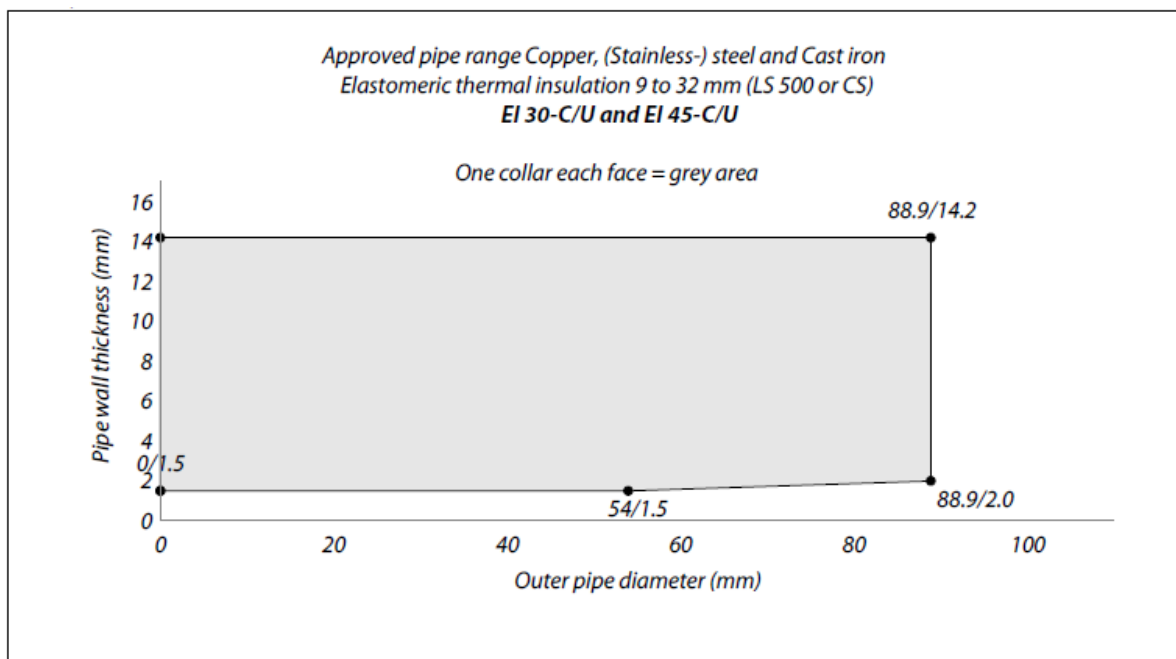

Approved pipe range Copper, (Stainless-) steel and Cast iron
Elastomeric thermal insulation 9 to 32 mm (LS 500 or CS)
EI 30-C/U, EI 45-C/U and EI 60-C/U

One collar each face = grey area

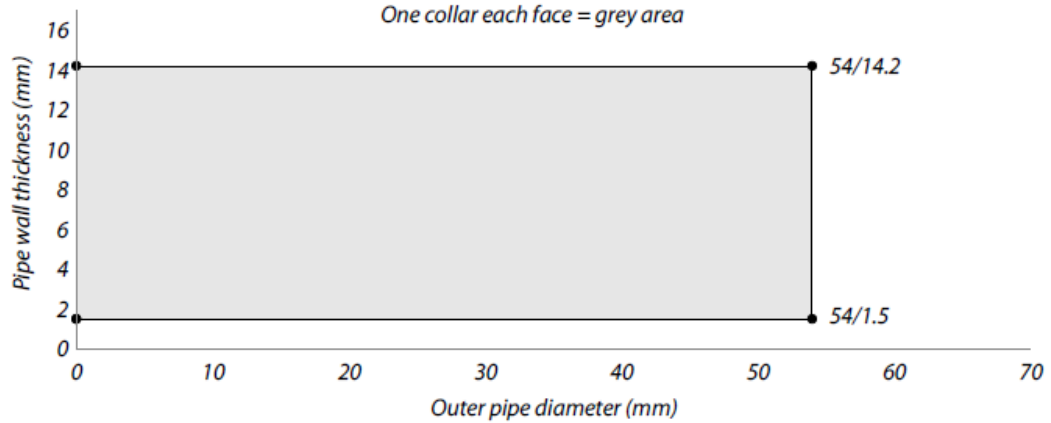

Approved pipe range Copper, (Stainless-) steel and Cast iron
Elastomeric thermal insulation 32 mm (CS)
EI 30-C/U, EI 45-C/U and EI 60-C/U

One collar each face = grey area

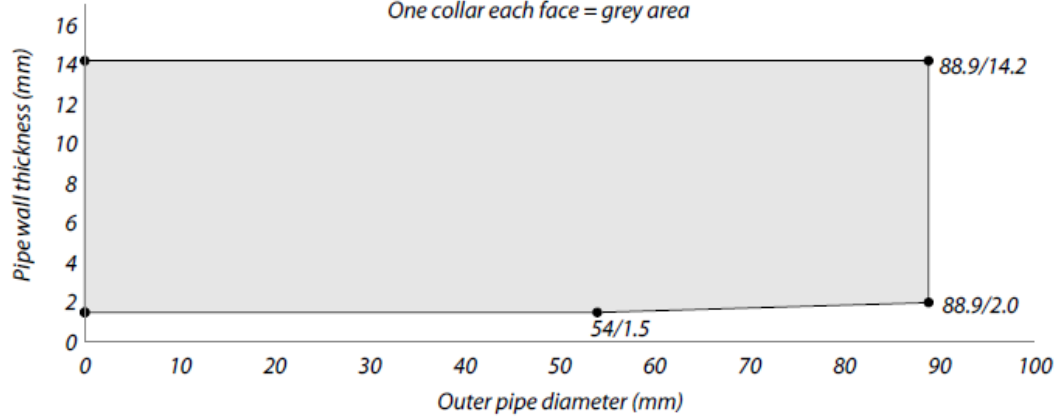

Approved pipe range Copper, (Stainless-) steel and Cast iron
Elastomeric thermal insulation 32 mm (LS 500 or CS)
EI 30-C/U, EI 45-C/U, EI 60-C/U and EI 90-C/U

One collar each face = grey area

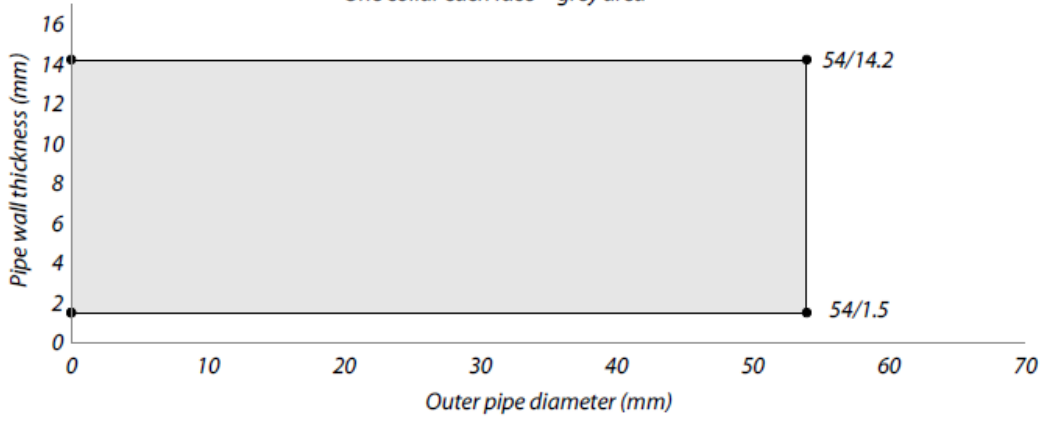

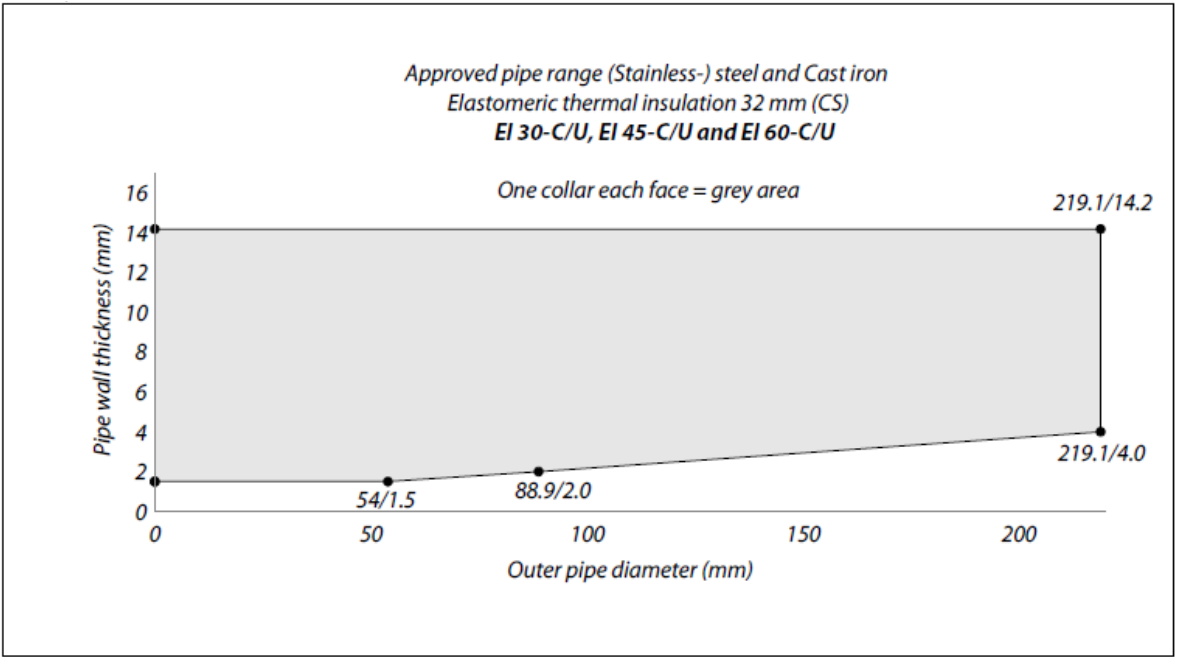
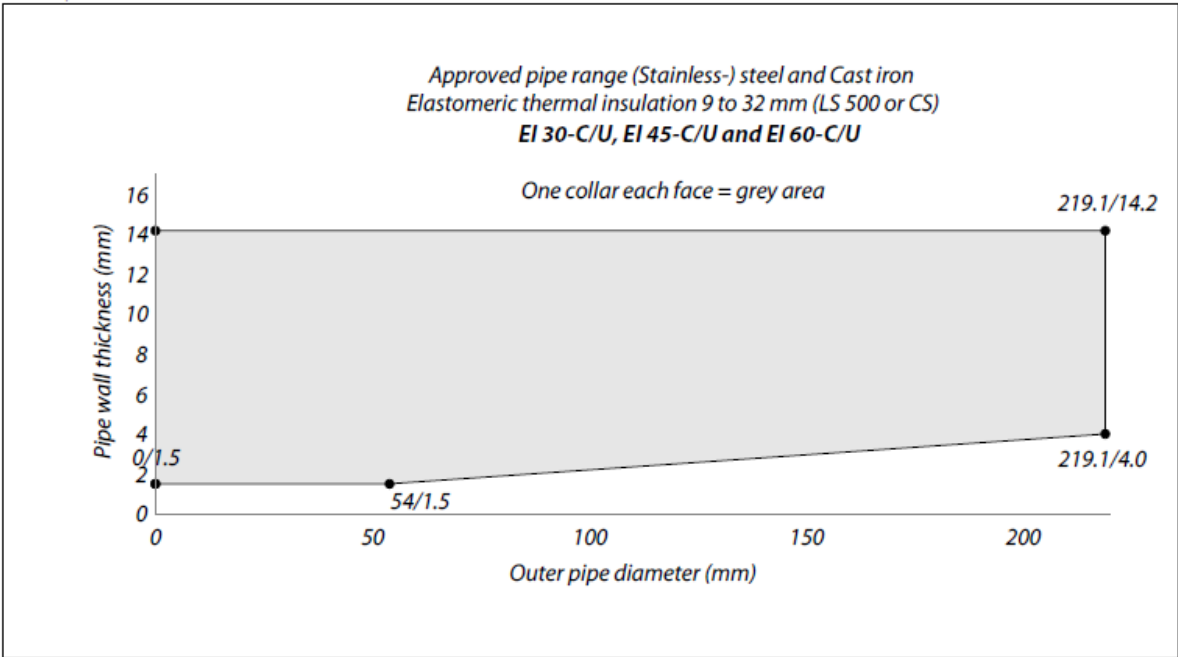

Approved pipe range (Stainless-) steel and Cast iron
Elastomeric thermal insulation 32 mm (CS)
EI 30-C/U, EI 45-C/U, EI 60-C/U and EI 90-C/U

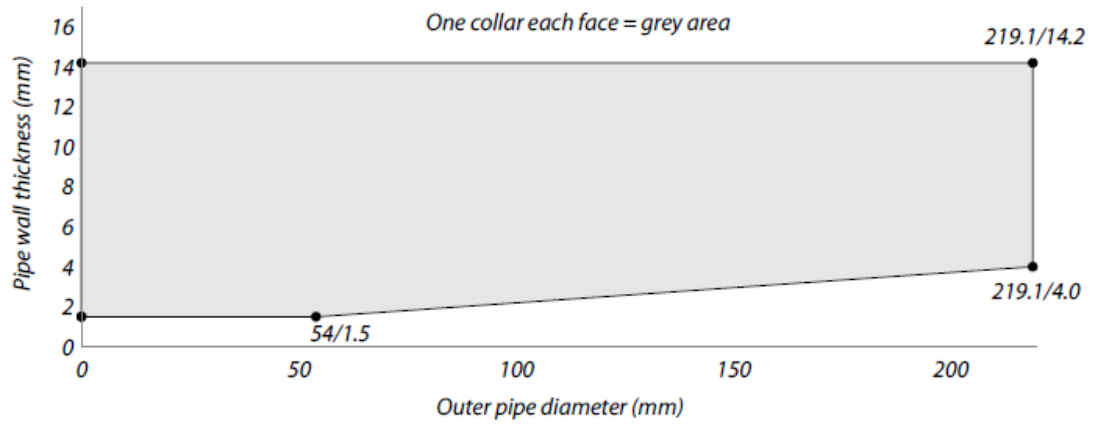

A.8.1.2 Metal pipes insulated with AF/Armaflex made out of flexible elastomeric EPDM rubber foam with min. reaction to fire class BL-s3, d0 or B-s3, d0 (EN 13501-1), fitted perpendicular to the wall, with one Mulcol® Multicollar Slim pipe collars to both sides of the wall.

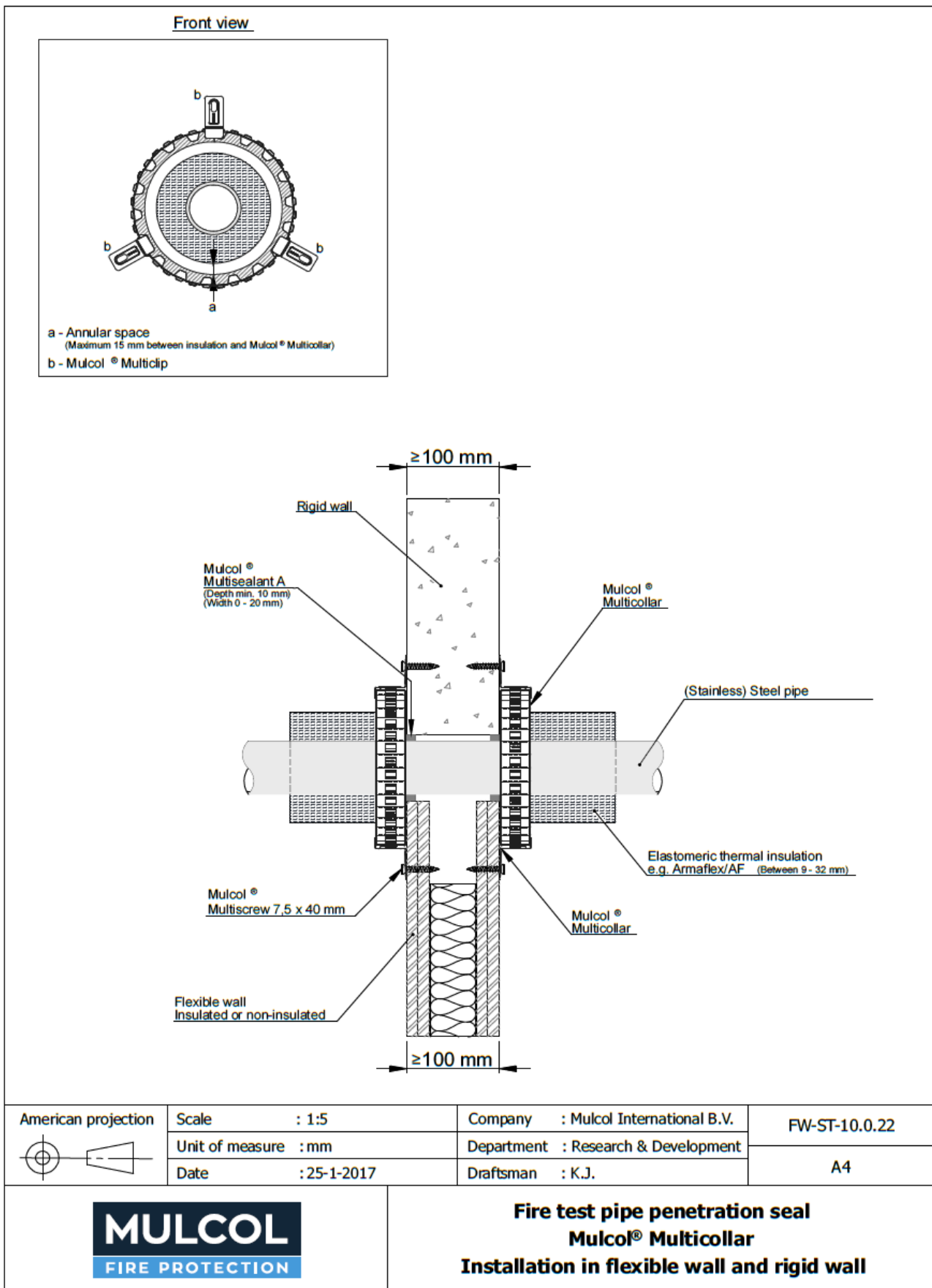

Pipe material	Maximum Pipe diameter mm	Pipe wall thickness mm	Insulation CI thickness mm	No. of collars per face	Classification*
Steel / Iron / Stainless Steel	168.3	4.5-14.2	32	One	EI 120 C/U
			9-32		E 120 C/U EI 60 C/U

* C/U pipe end configuration applies to C/C also

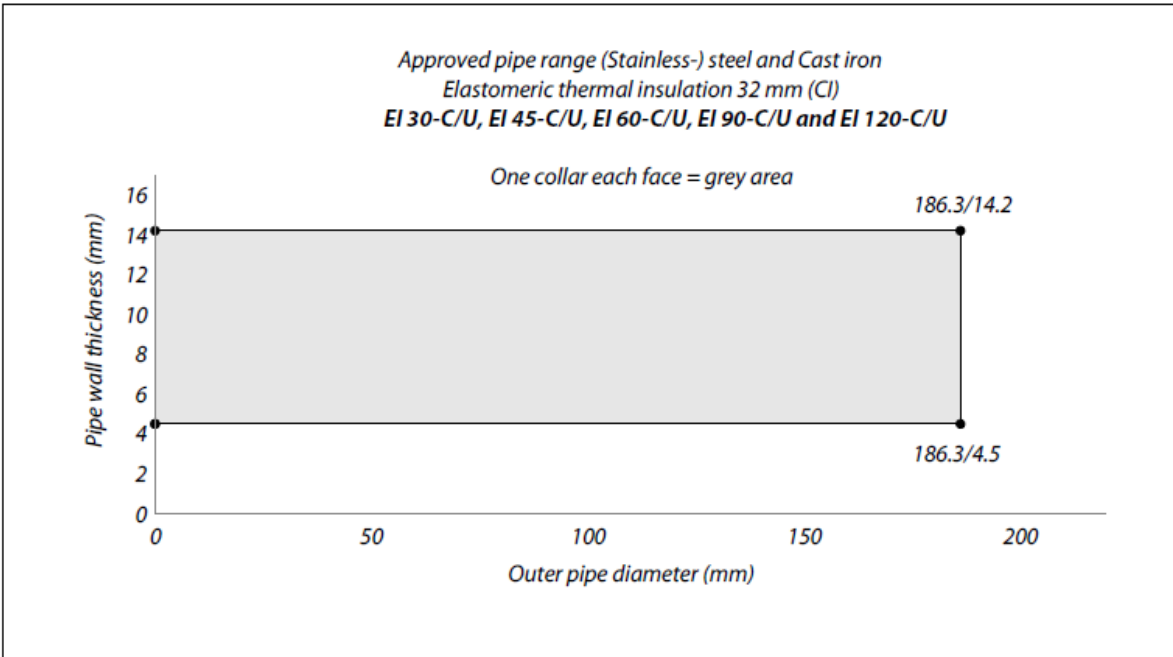
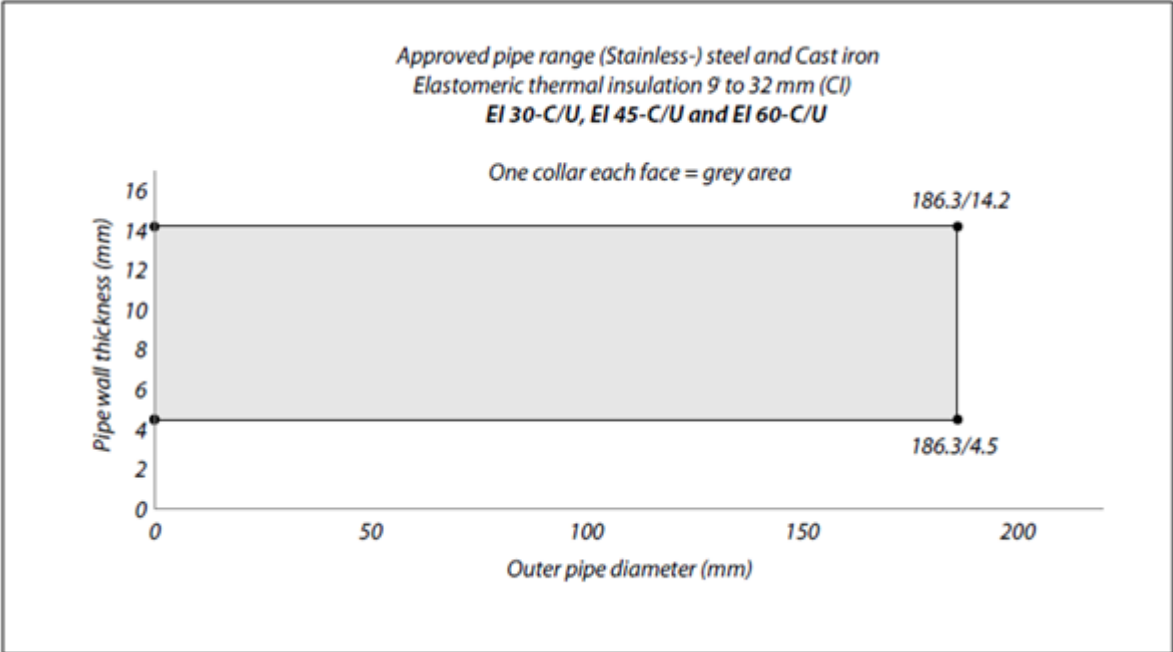

A.8.1.3 Metal pipes insulated with AF/Armaflex made out of flexible elastomeric EPDM rubber foam with min. reaction to fire class BL-s3, d0 or B-s3, d0 (EN 13501-1), fitted perpendicular to the wall, with two Mulcol® Multicollar Slim pipe collars to both sides of the wall.

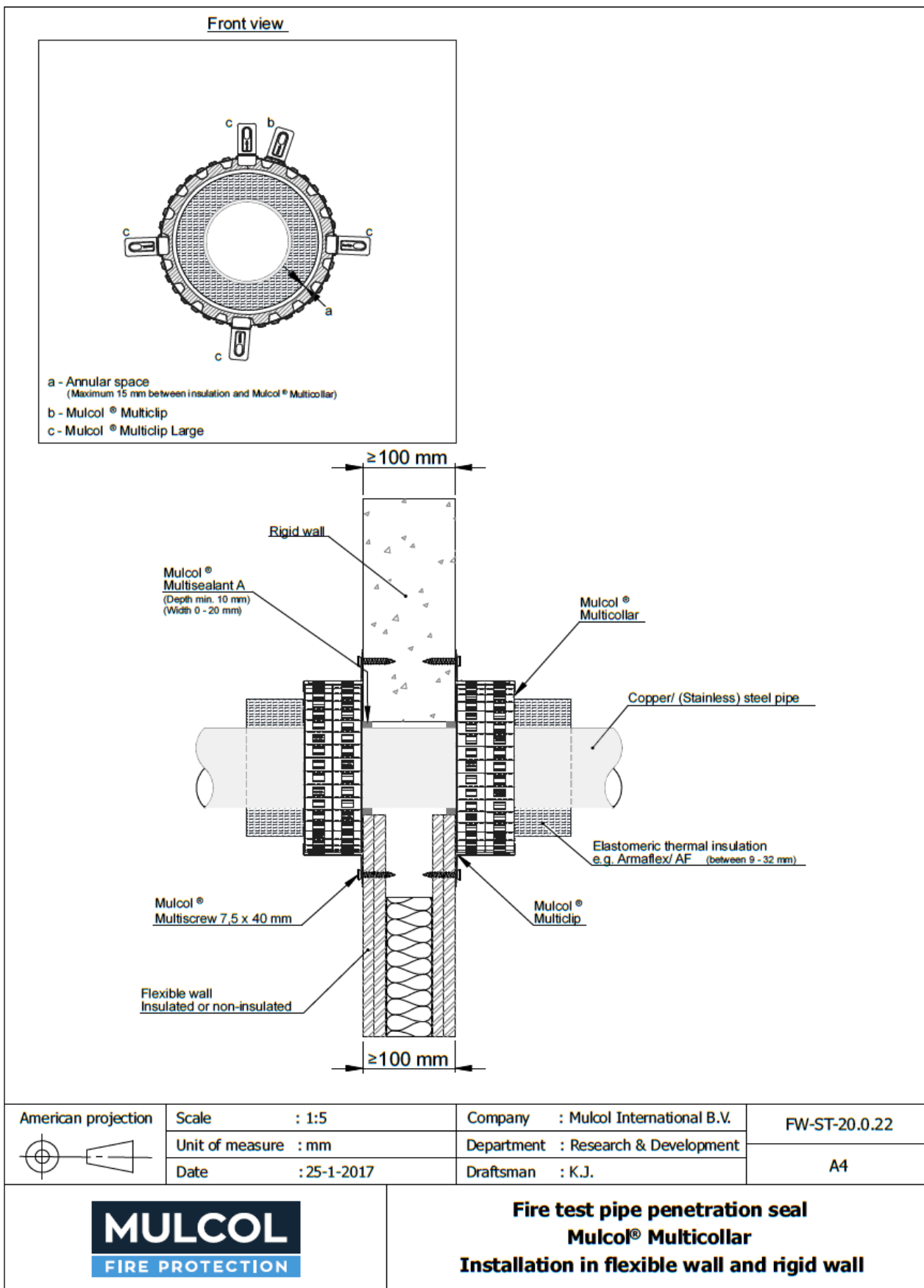

Pipe material	Maximum Pipe diameter mm	Pipe wall thickness mm	Insulation CI thickness mm	No. of collars per face	Classification*
Copper / Steel / Iron / Stainless Steel	88.9	2.0-14.2	9-32	Two	E 120 C/U EI 60 C/U
			32		EI 120 C/U

* C/U pipe end configuration applies to C/C also

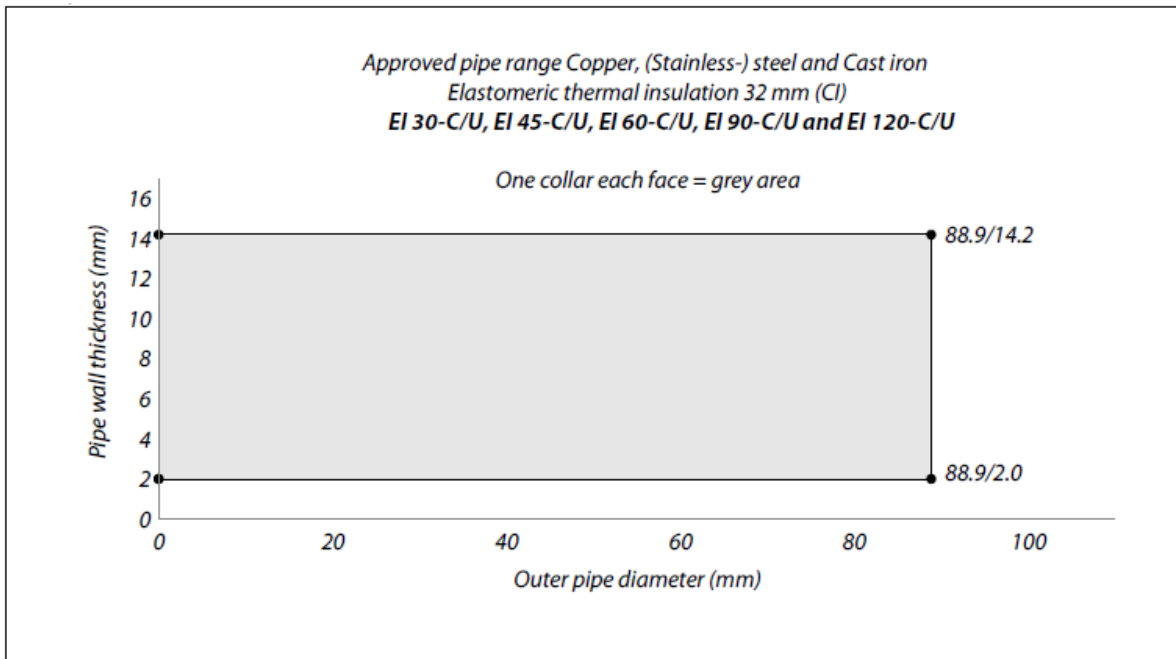
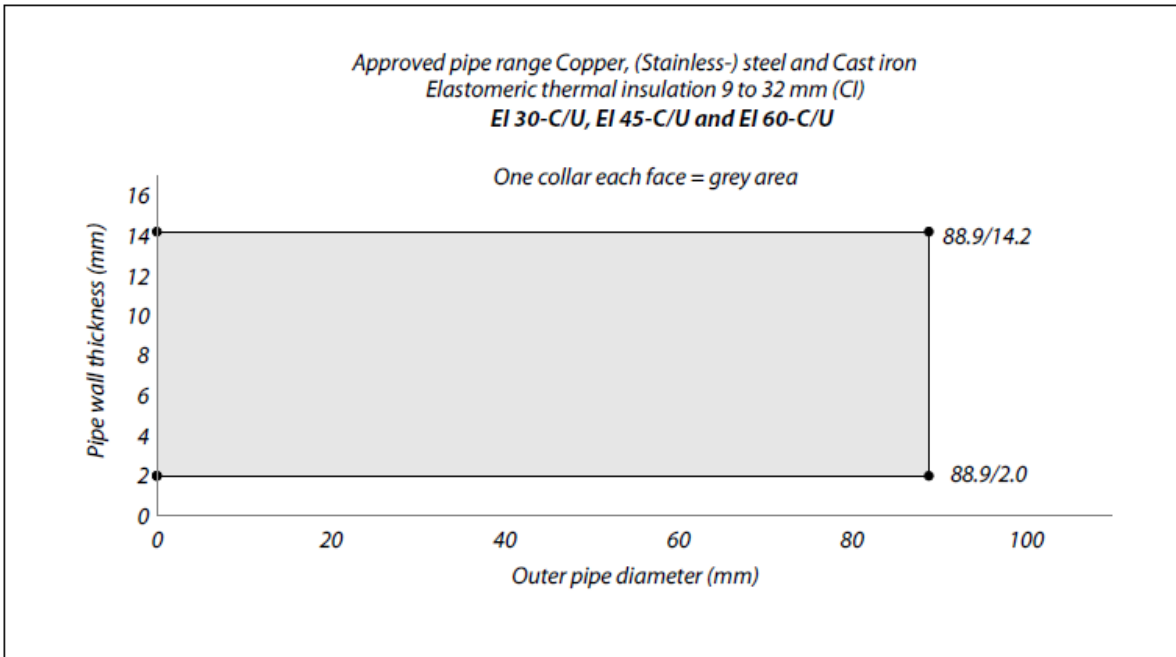

A.8.1.4 Metal pipes insulated with PIR or PUR foam with min. reaction to fire class E (EN 13501-1), fitted perpendicular to the wall, with one Mulcol® Multicollar Slim pipe collars to both sides of the wall.

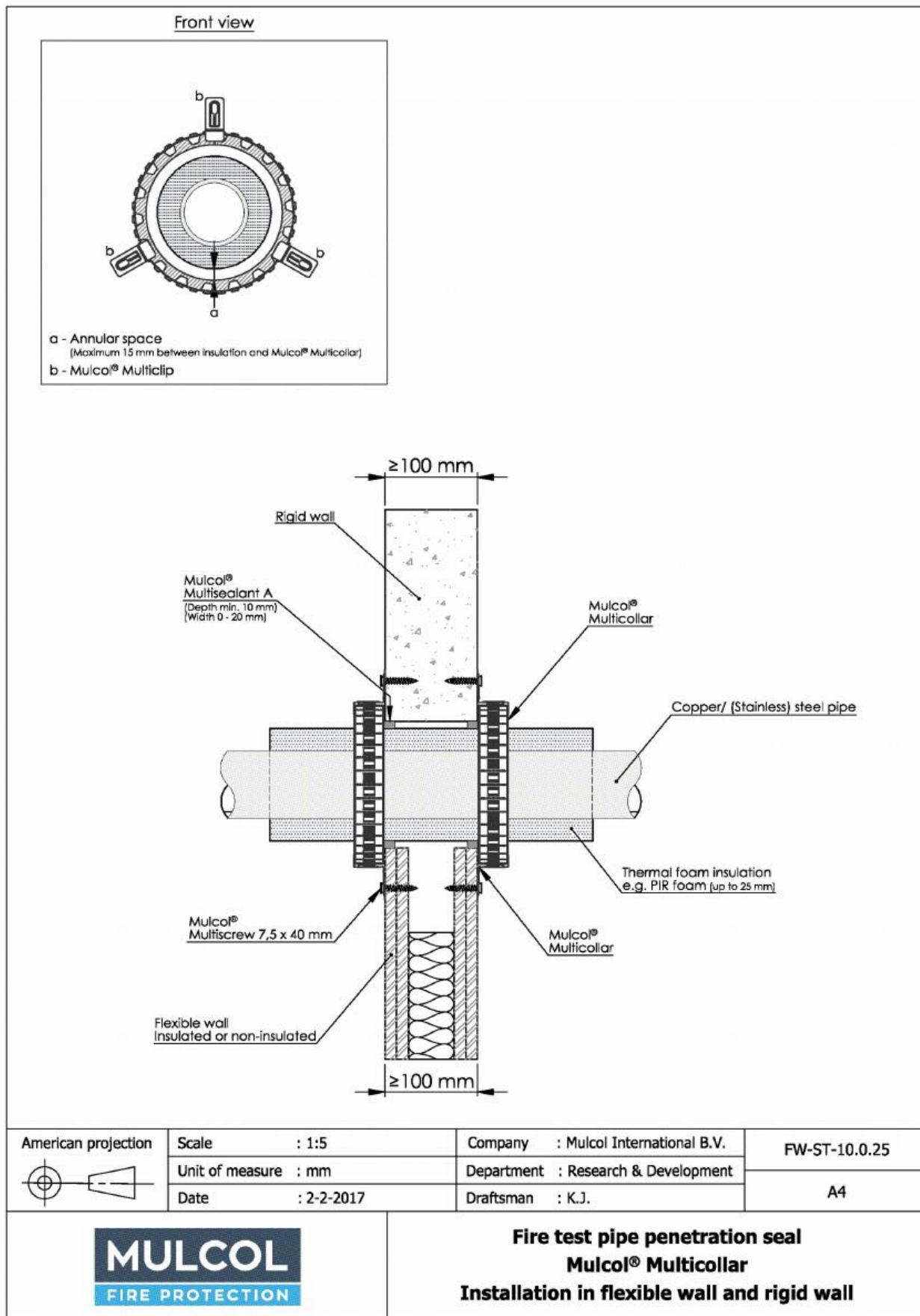

Pipe material	Maximum	Pipe wall	Insulation LS/CS	No. of collars	Classification*
---------------	---------	-----------	------------------	----------------	-----------------

	Pipe diameter mm	thickness mm	length / thickness mm	per face	
Copper / Steel / Iron / Stainless	54	1.5-14.2	25 / 500 (min.)	One	E 120 C/U EI 60 C/U
	76.1	2.0-14.2			

* C/U pipe end configuration applies to C/C also

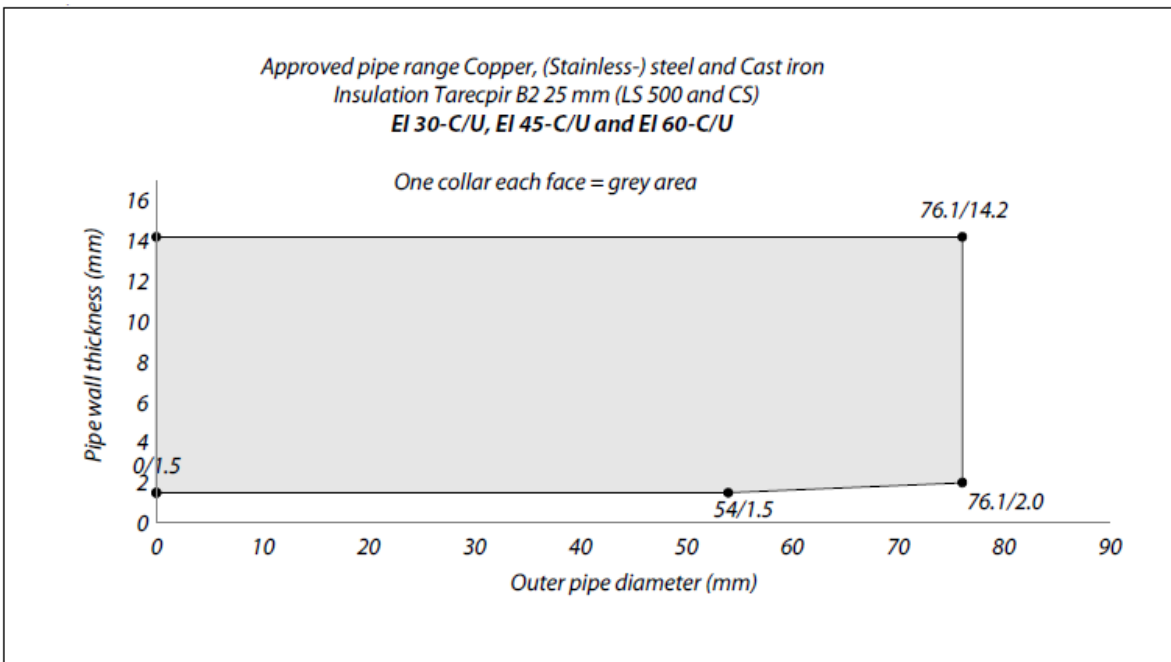
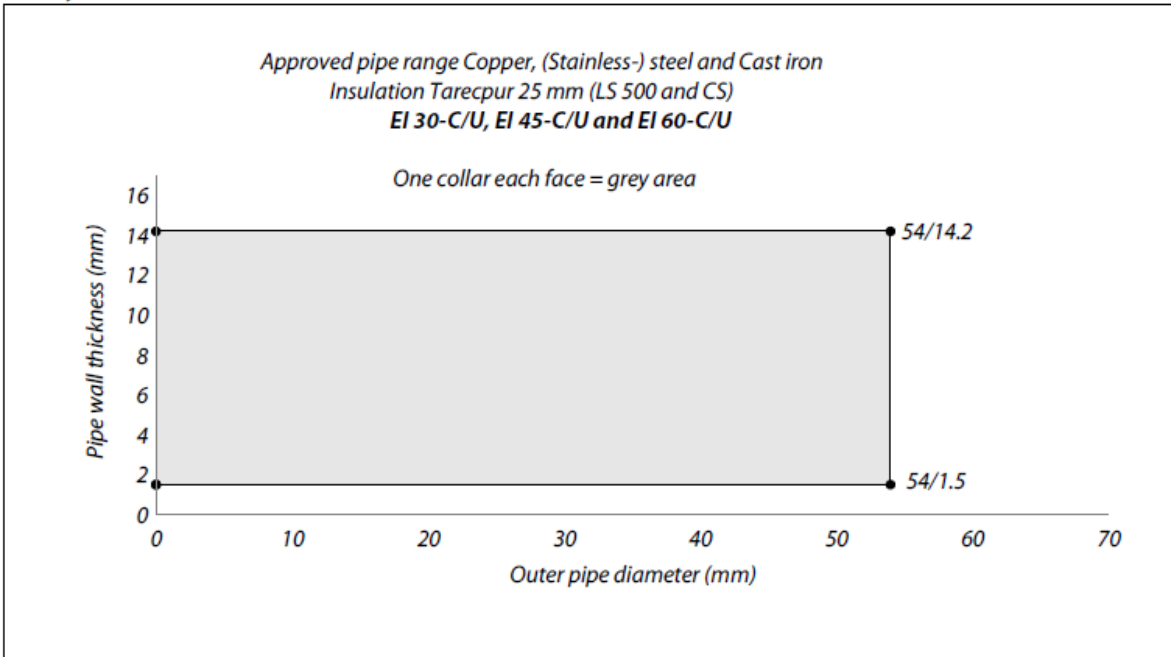

A.8.1.5 Metal pipes insulated with PIR or PUR foam with min. reaction to fire class E (EN 13501-1), fitted perpendicular to the wall, with two Mulcol® Multicollar Slim pipe collars to both sides of the wall.

Front view

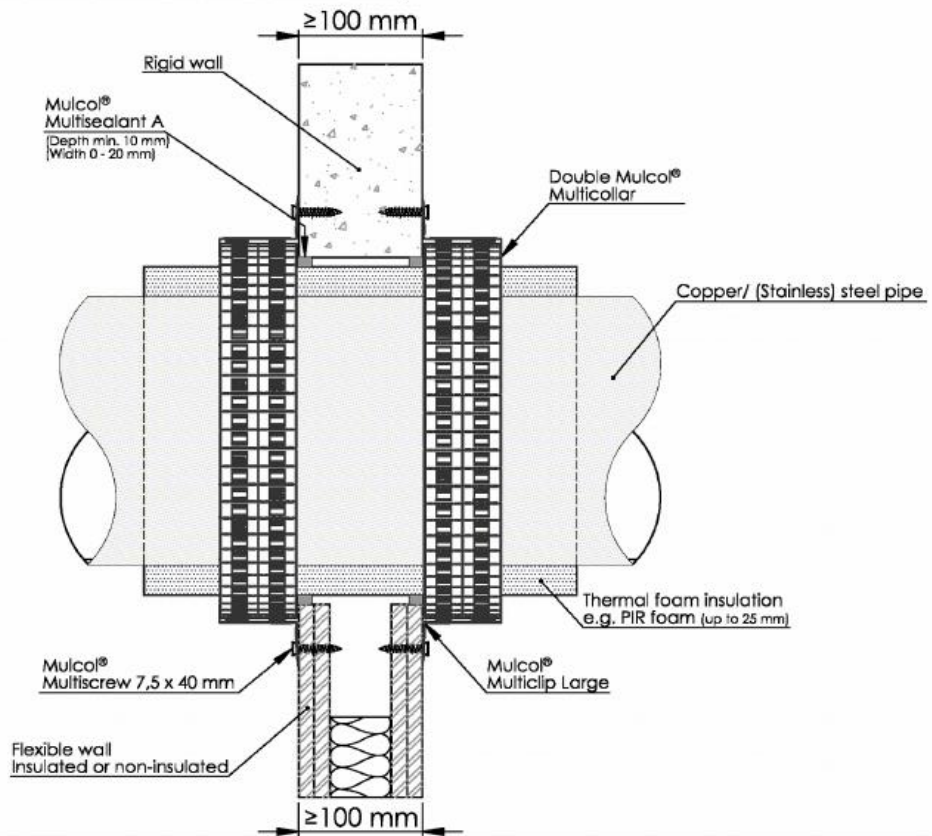
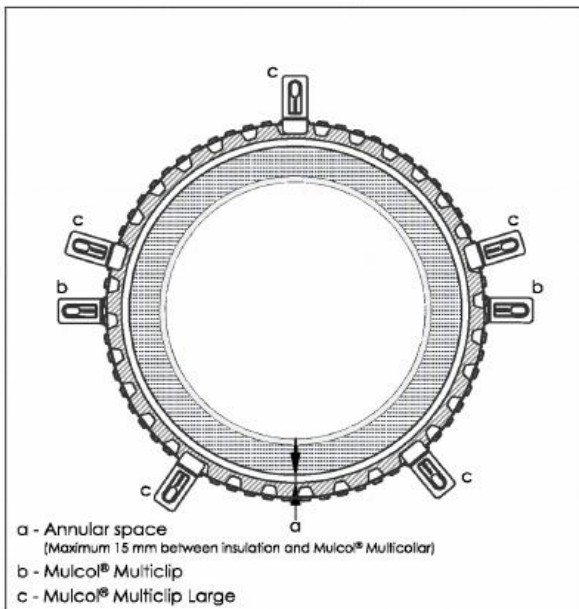

	Scale : 1:5	Company : Mulcol International B.V.	FW-ST-20.0.25
	Unit of measure : mm	Department : Research & Development	
	Date : 2-2-2017	Draftsman : K.J.	A4



**Fire test pipe penetration seal
Mulcol® Multicollar
Installation in flexible wall and rigid wall**

Pipe material	Maximum Pipe diameter mm	Pipe wall thickness mm	Insulation LS/CS length / thickness mm	No. of collars per face	Classification*

Steel / Iron / Stainless Steel	219.1	4.0-14.2	LS 25 / 500 (min.)	Two	E 120 C/U EI 60 C/U
			CS 25		E 120 C/U EI 90 C/U

* C/U pipe end configuration applies to C/C also

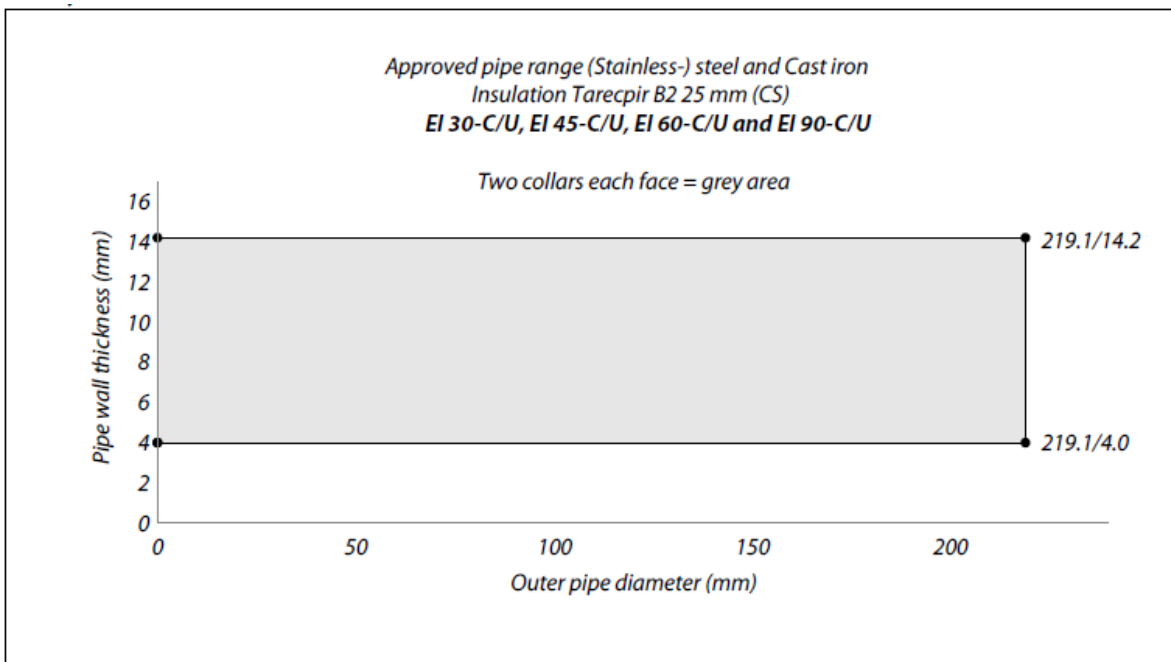
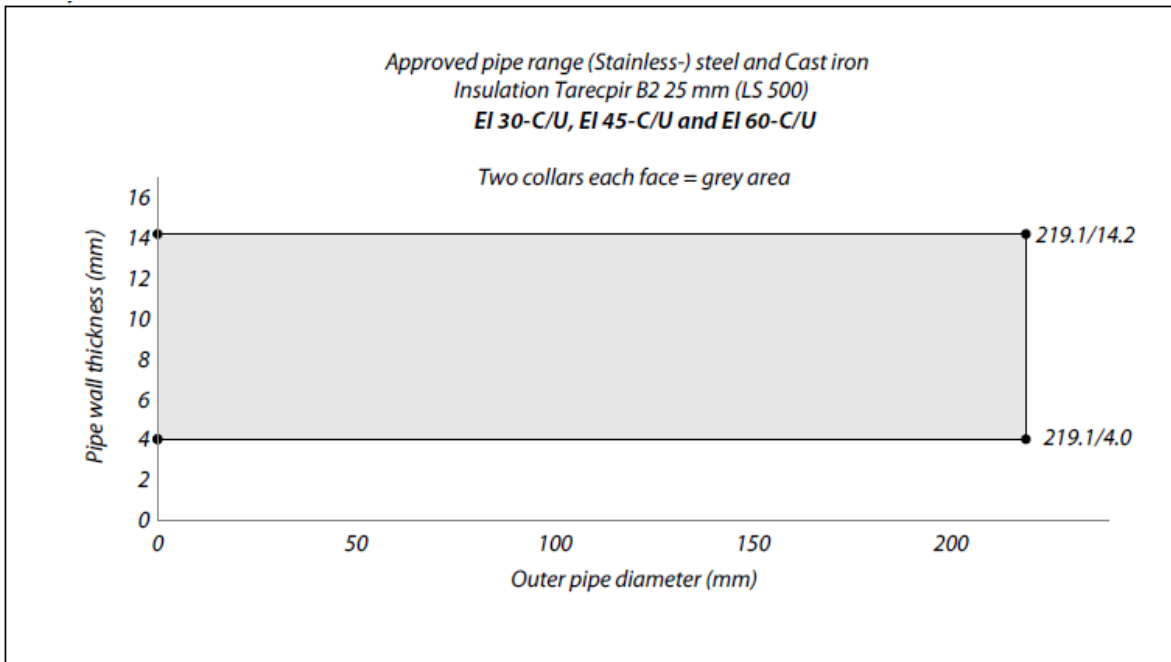

Annex B - Resistance to Fire Classification – Mulcol® Multicollar Slim - Rigid floor constructions according to Section 2 1) with floor thickness of minimum 150 mm

B.1 Plastic pipes

B.1.1 Plastic Pipes in regular configurations

B.1.1.1 Plastic pipes fitted perpendicular to the floor, with one or two Mulcol® Multicollar Slim pipe collars to the soffit.

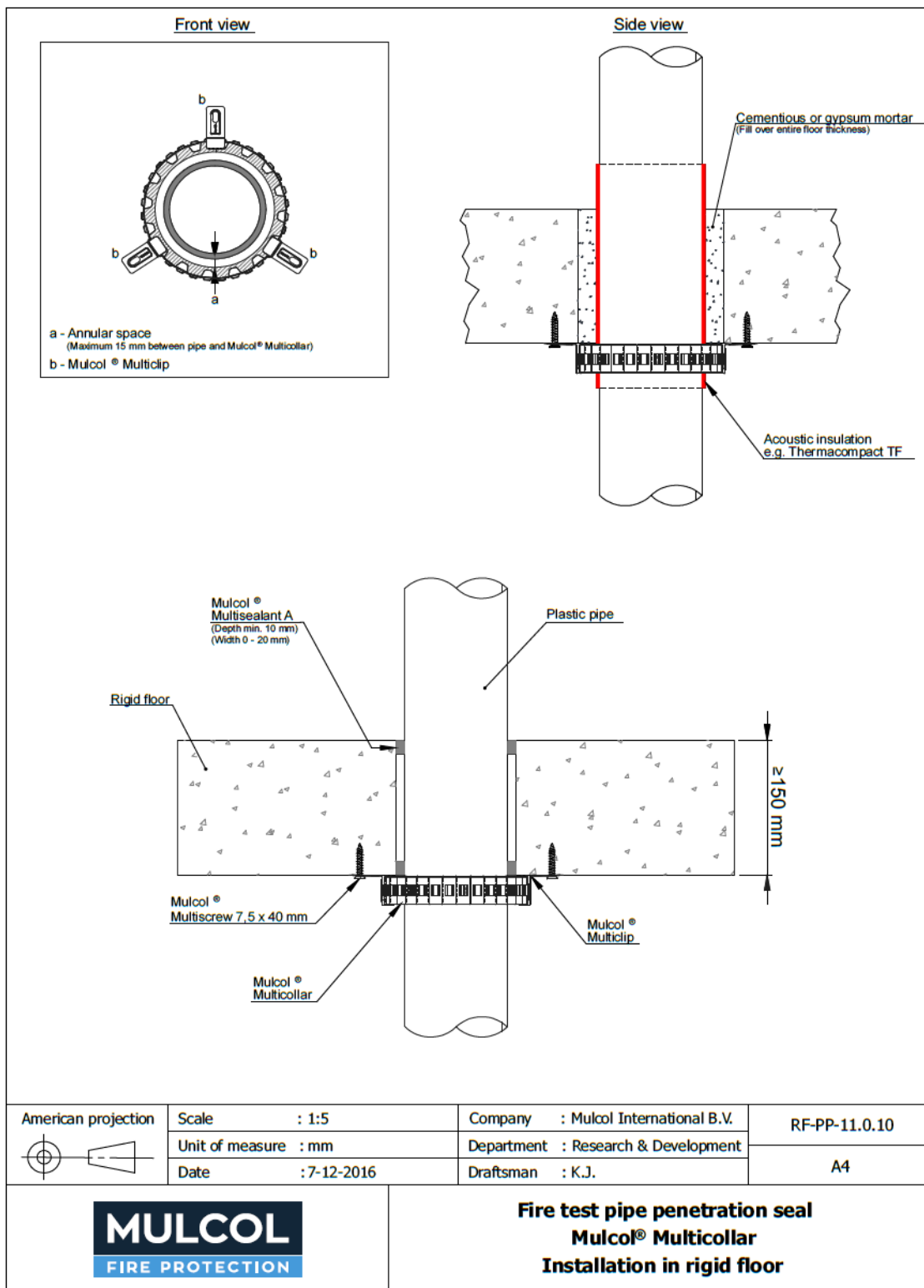

Front view

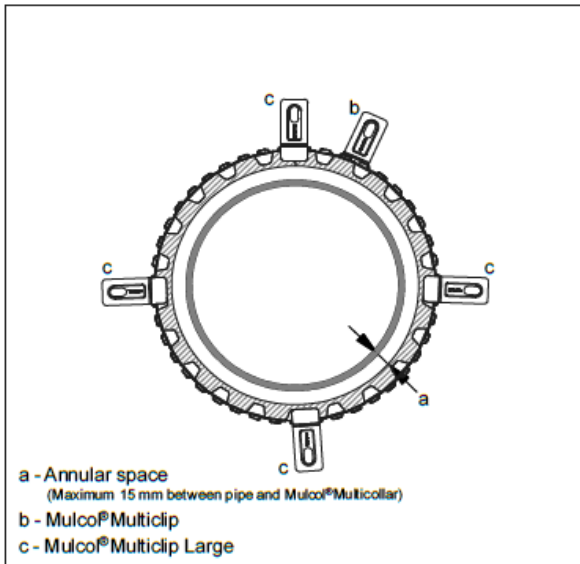

Side view

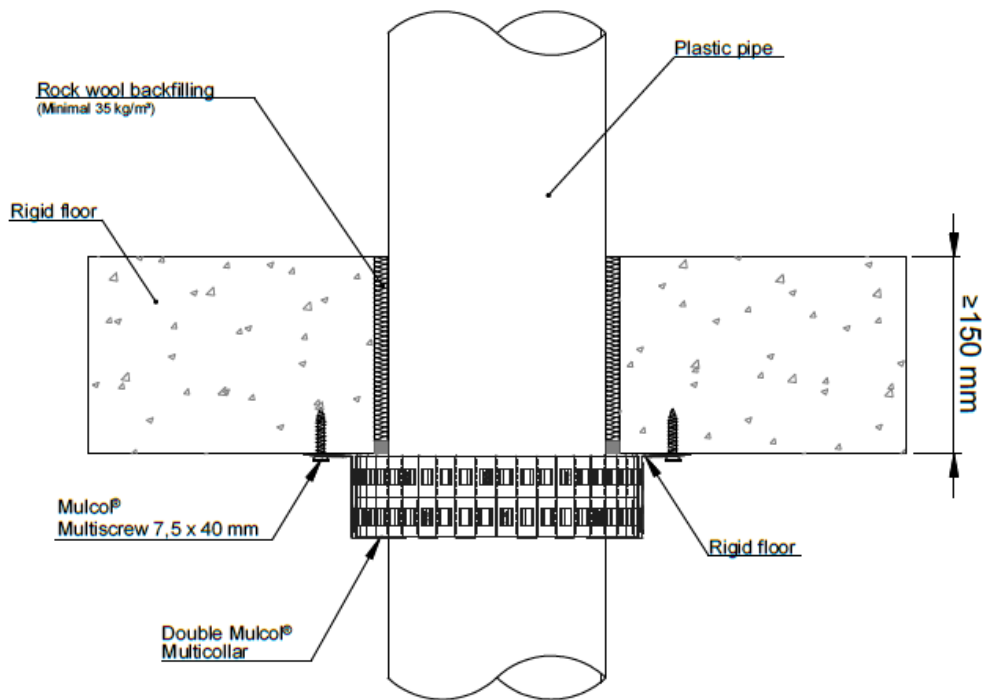
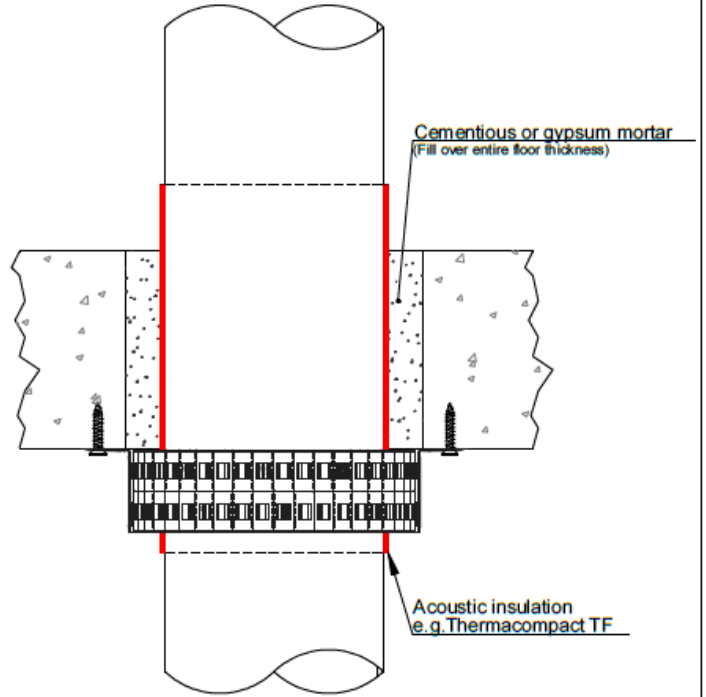

American projection

Scale : 1:5

Company : Mulcol International B.V.

RF-PP-21.0.10

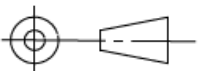

Unit of measure : mm

Department : Research & Development

Date : 7-12-2016

Draftsman : K.J.

A4



Fire test pipe penetration seal
Mulco® Multicollar
Installation in rigid floor

Pipe material [^]	Maximum pipe diameter mm	Pipe wall thickness mm	No. of collars per face	Classification*	
PE-HD / PE / ABS / SAN+PVC	40	2.4-6.6	one	EI 120 U/U	
		6.6-14.6		EI 120 U/C	
	110	6.6		EI 120 U/U	
		2.7-6.6		EI 90 U/U	
		6.6-14.6		EI 120 U/C	
	125	4.0-4.9		EI 90 U/U	
		4.9-14.6		EI 90 U/C	
	160	4.0		EI 60 U/U	
		14.6		EI 120 U/C	
		4.0-14.6		EI 60 U/C	
		4.0	two	EI 90 U/U	
		4.0-14.6		EI 90 U/C	
	PP	40	1.8-6.3	one	EI 120 U/U
			6.3-14.6		EI 120 U/C
110		2.7-6.3	EI 90 U/U		
		14.6	EI 120 U/C		
		2.7-14.6	EI 90 U/C		
125		3.1-4.0	EI 90 U/U		
		4.0-4.8	EI 60 U/U		
		14.6	EI 120 U/C		
		3.1-14.6	EI 90 U/C		
160		4.0	EI 90 U/U		
		14.6	EI 120 U/C		
		4.0-14.6	EI 90 U/C		

* U/U pipe end configuration applies to U/C, C/U and C/C also

[^] Pipes may optionally be fitted with up to 4 mm thick sound decoupling insulation, min. 50 mm long (LS/CS/LI/CI)

Pipe material [^]	Maximum pipe diameter mm	Pipe wall thickness mm	No. of collars per face	Classification*
PVC-U / PVC-C	40	1.9-8.2	one	EI 120 U/U
		8.2-14.6		EI 120 U/C
	110	2.2-8.2		EI 120 U/U
		8.2-12.3		EI 90 U/U
		8.2-14.6		EI 120 U/C
	125	4.0		EI 90 U/U
		2.5-4.8		EI 60 U/U
		4.8-14.6		EI 60 U/C
	160	4.0		EI 60 U/U
		1.8-4.0		EI 30 U/U
		14.6	EI 120 U/C	
		4.0-14.6	EI 60 U/C	
		3.2-11.8	EI 90 U/U	
		7.7-14.6	EI 120 U/C	
	315	7.7	two	EI 120 U/C

* U/U pipe end configuration applies to U/C, C/U and C/C also

[^] Pipes may optionally be fitted with up to 4 mm thick sound decoupling insulation, min. 50 mm long (LS/CS/LI/CI)

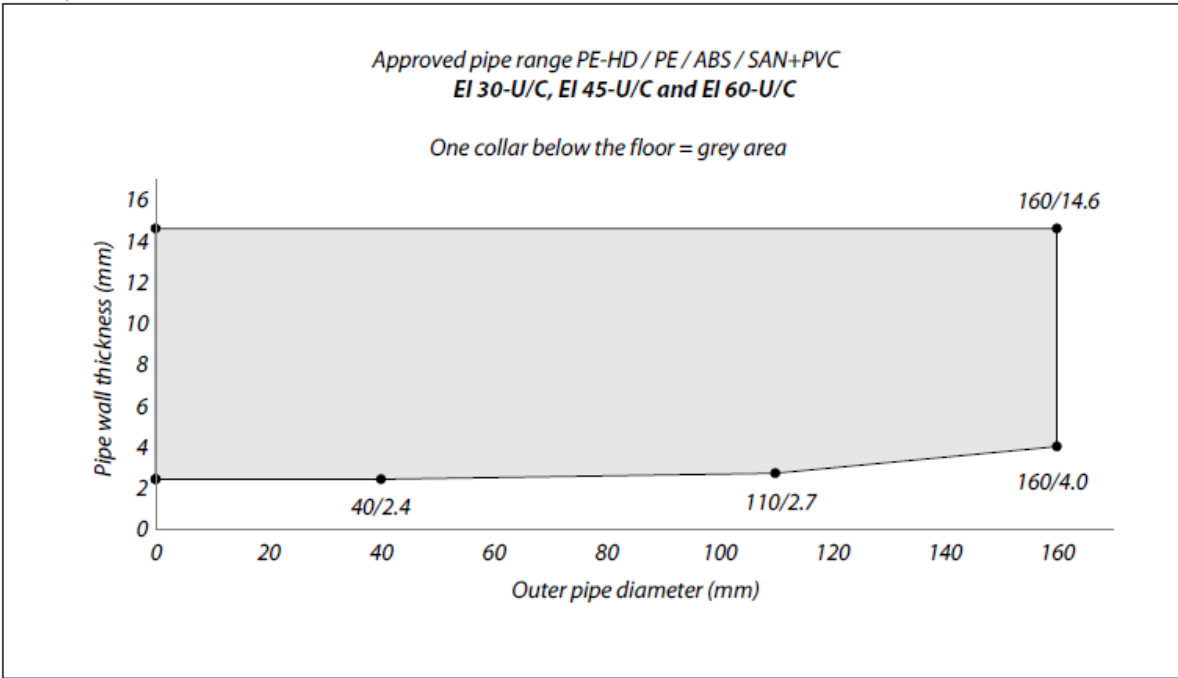
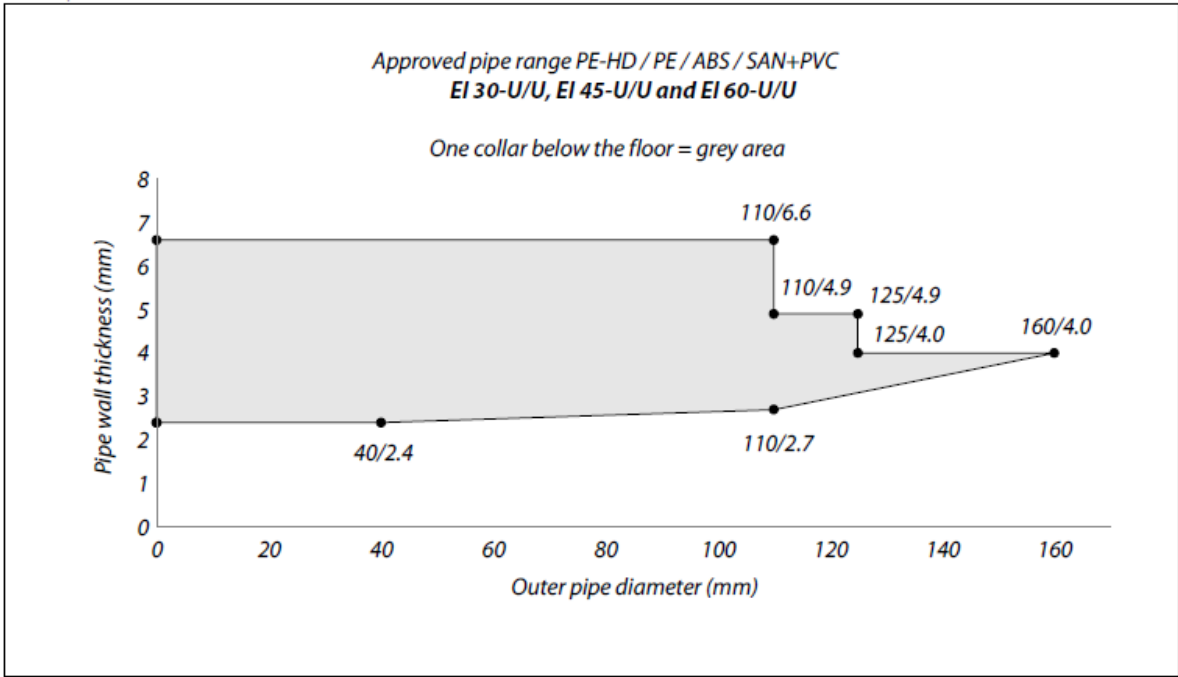

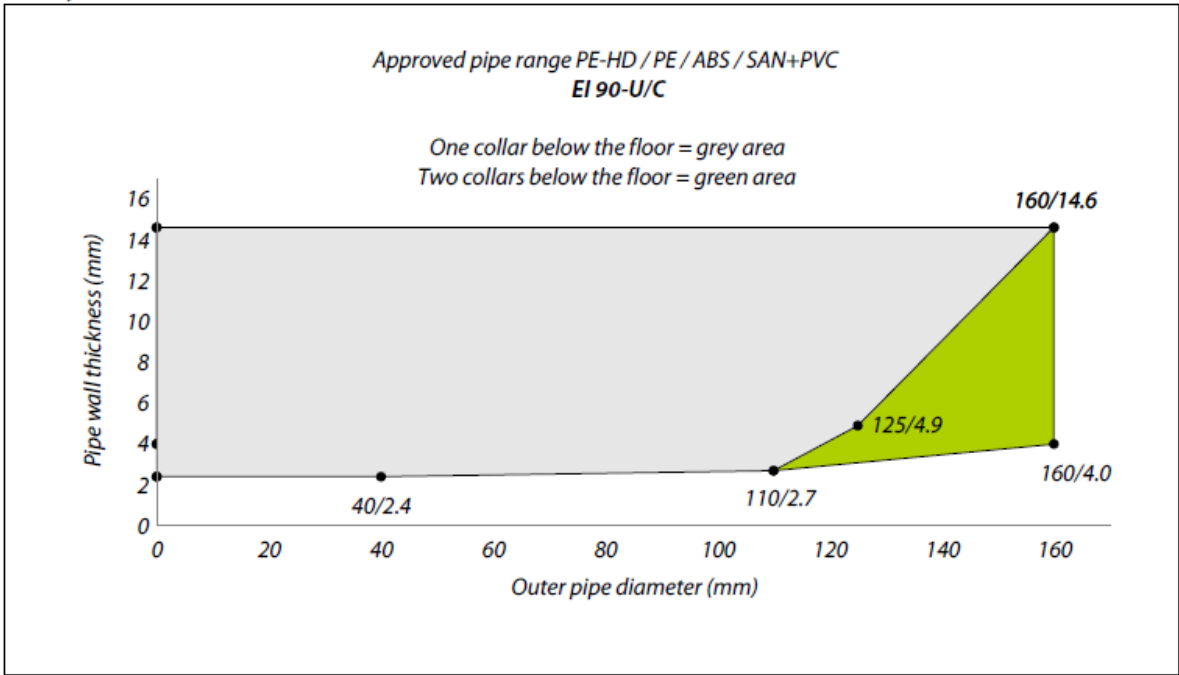
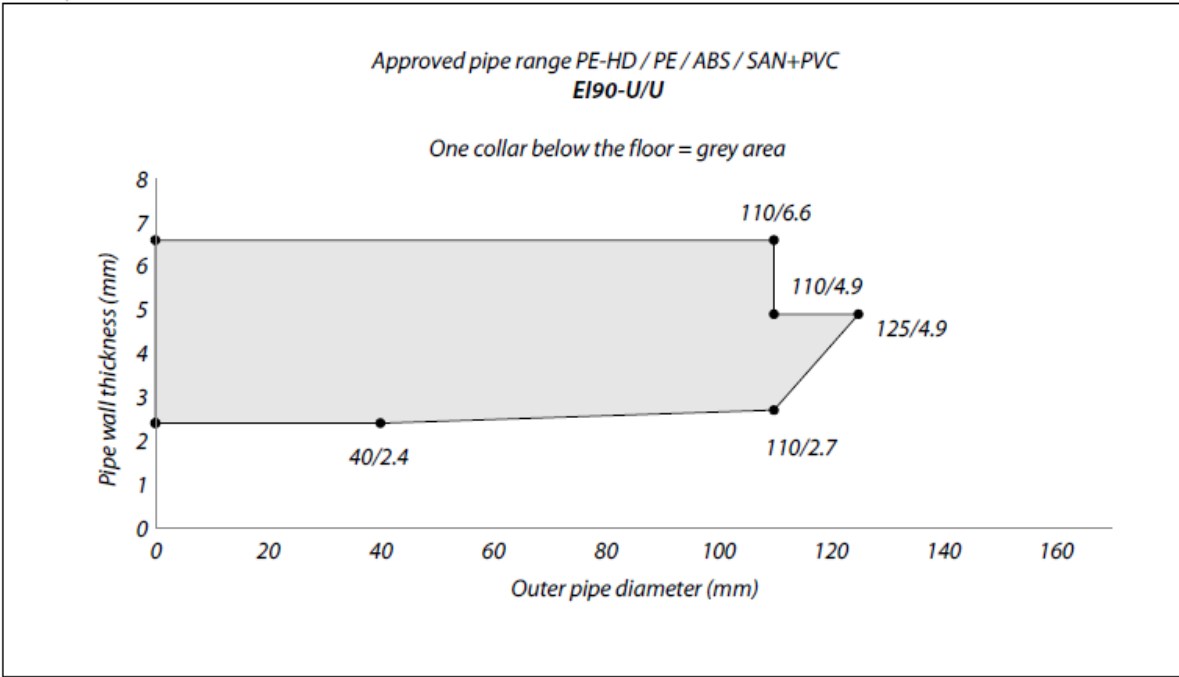

Approved pipe range PE-HD / PE / ABS / SAN+PVC
EI120-U/U

One collar below the floor = grey area

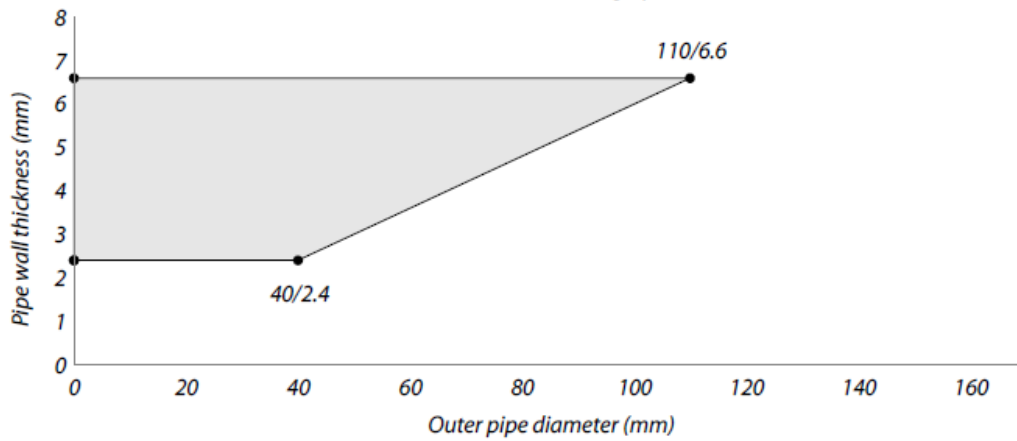

Approved pipe range PE-HD / PE / ABS / SAN+PVC
EI 120-U/C

One collar below the floor = grey area

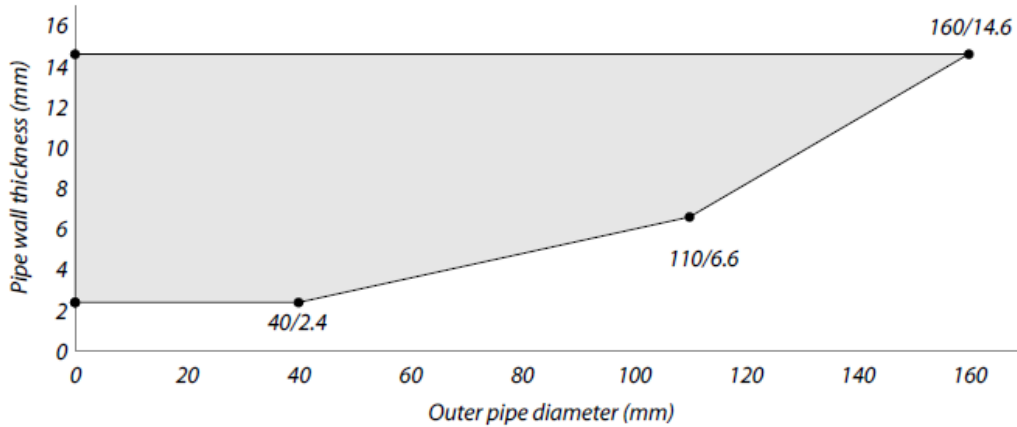

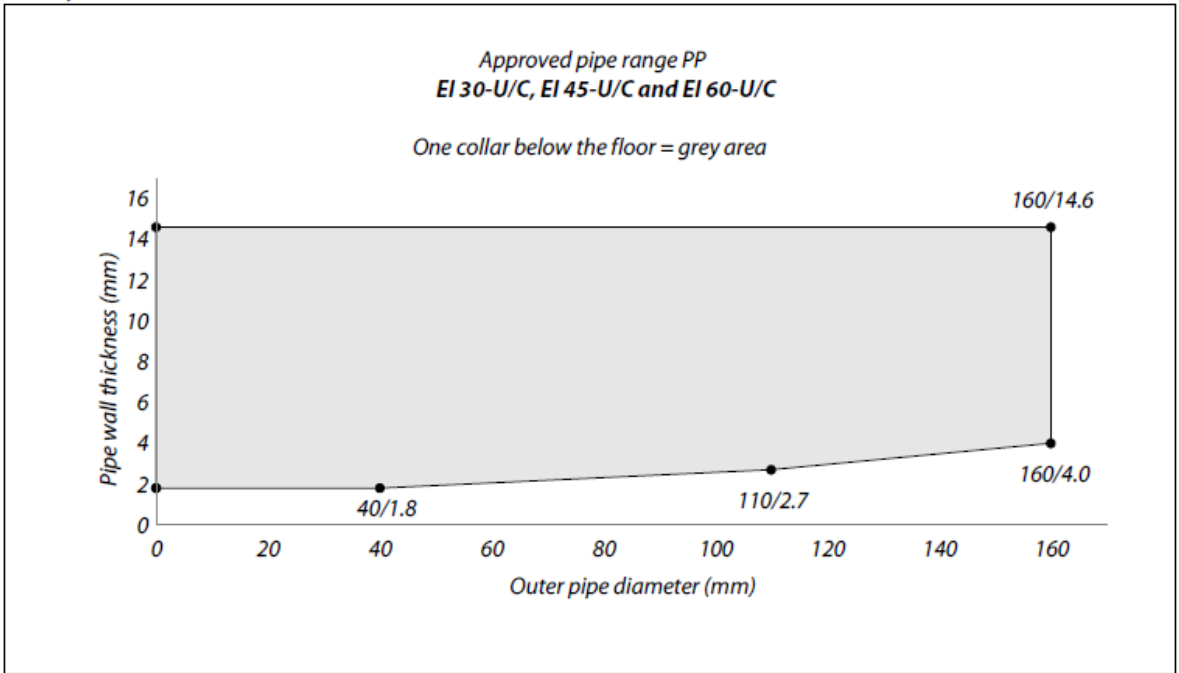
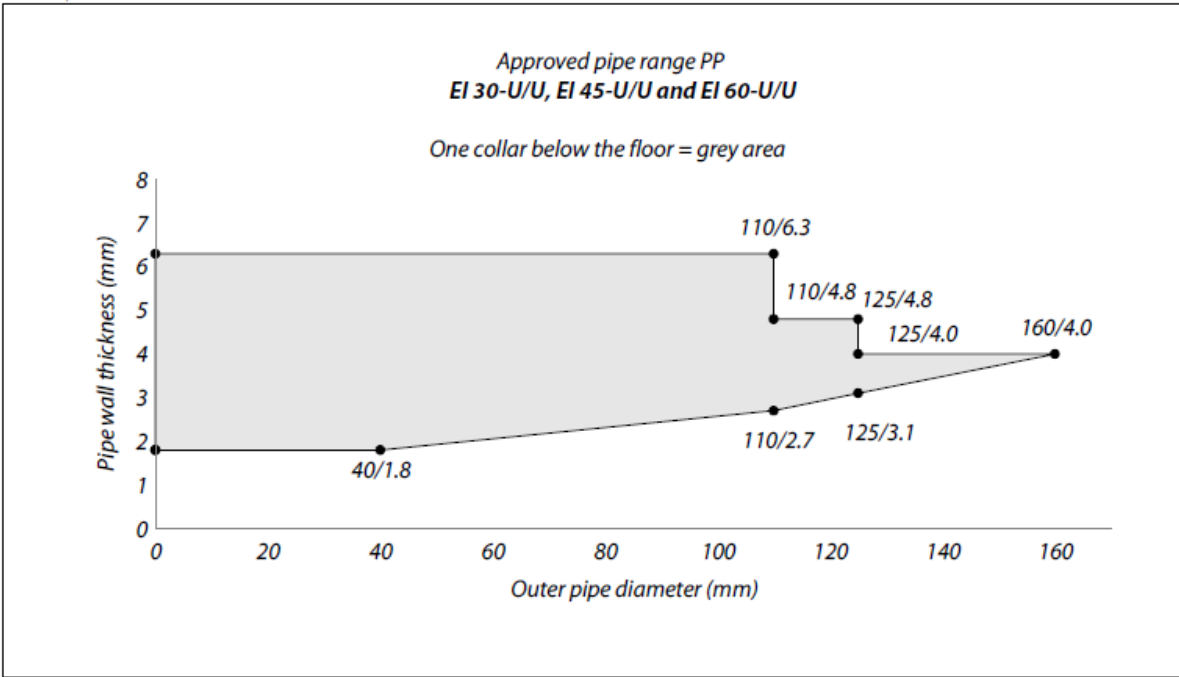

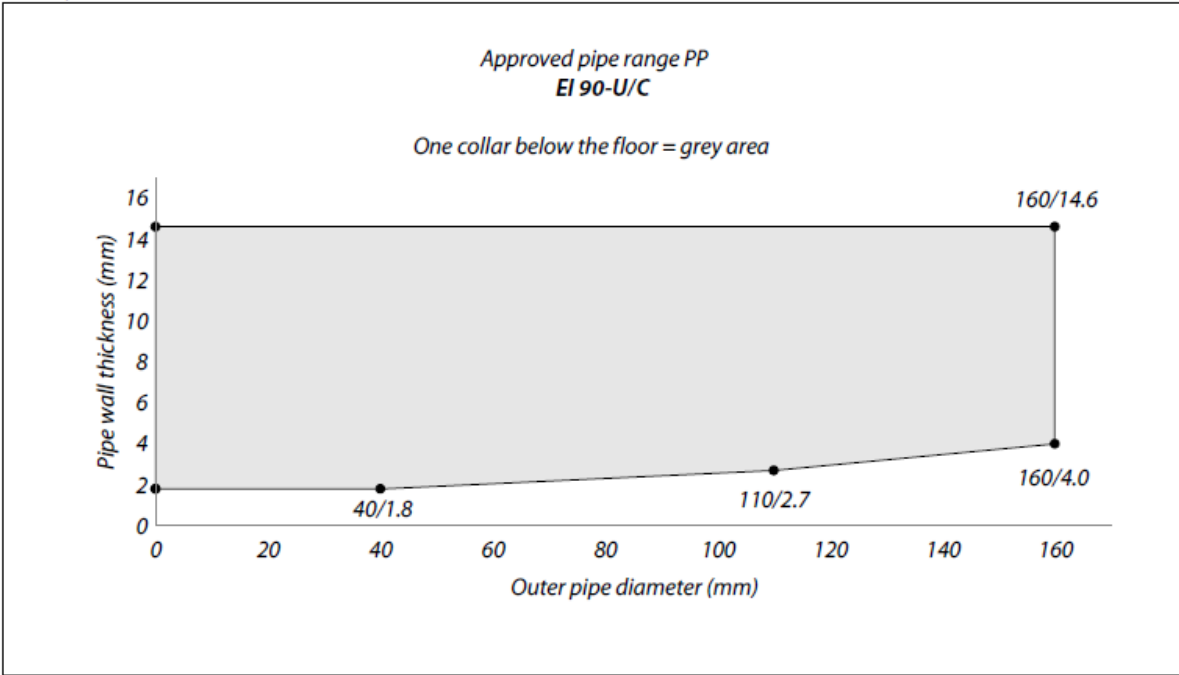
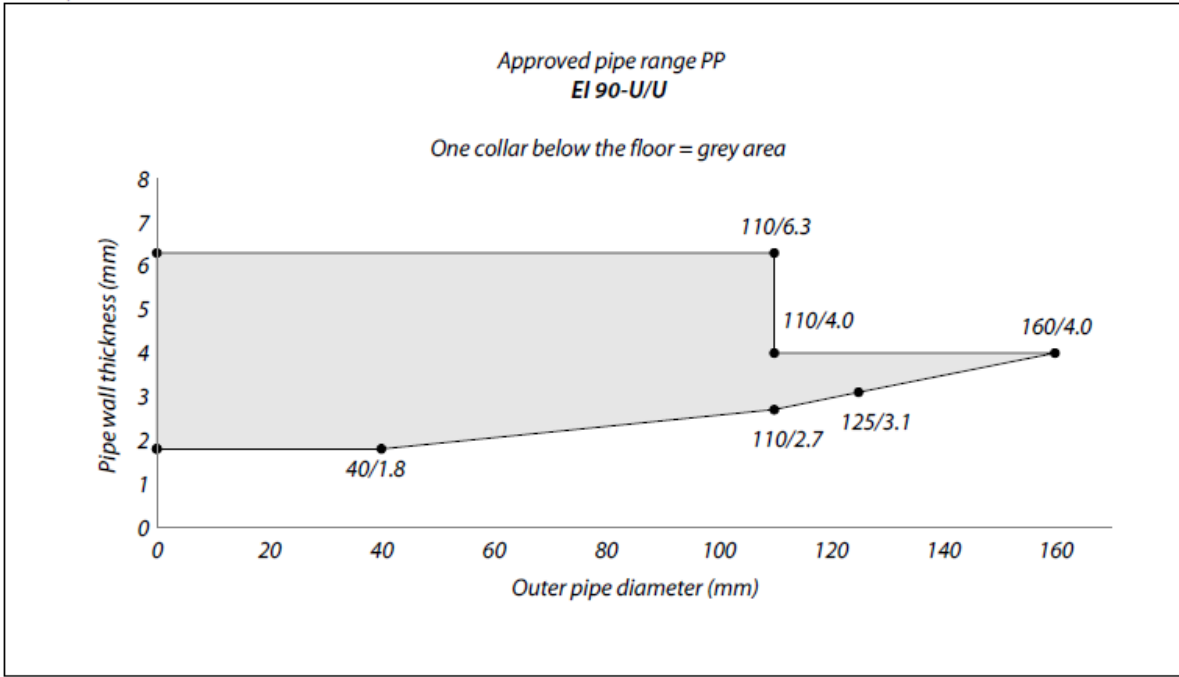

Approved pipe range PP
EI 120-U/U

One collar below the floor = grey area

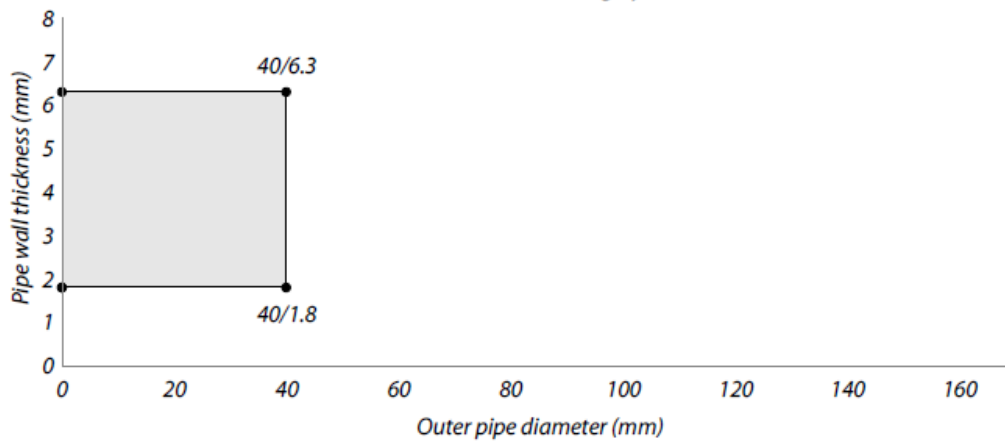

Approved pipe range PP
EI 120-U/C

One collar below the floor = grey area

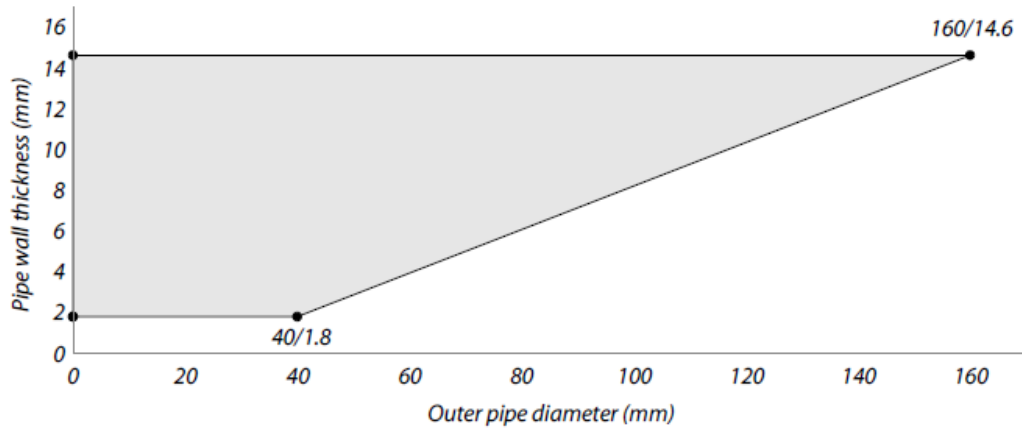

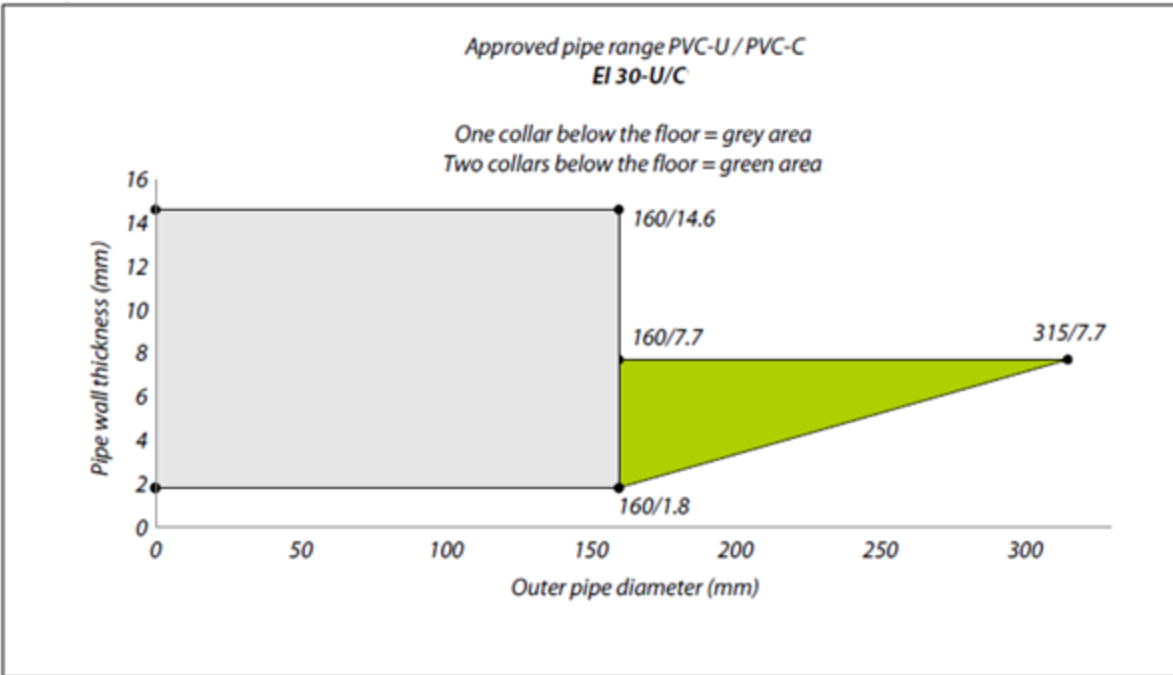
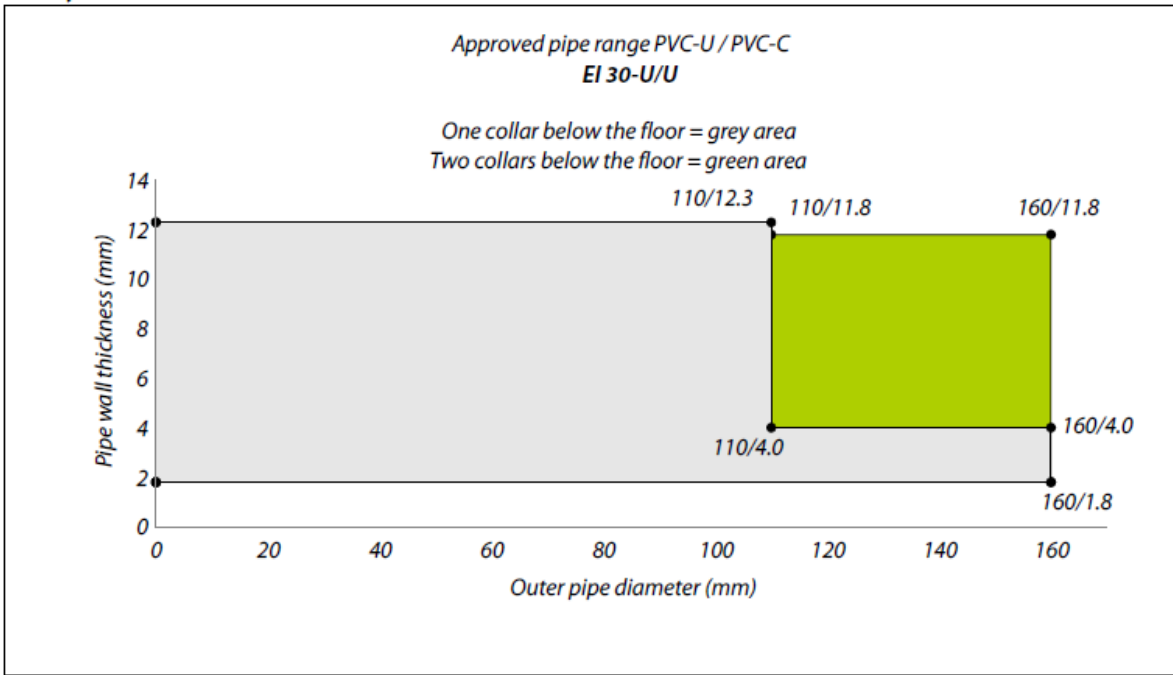

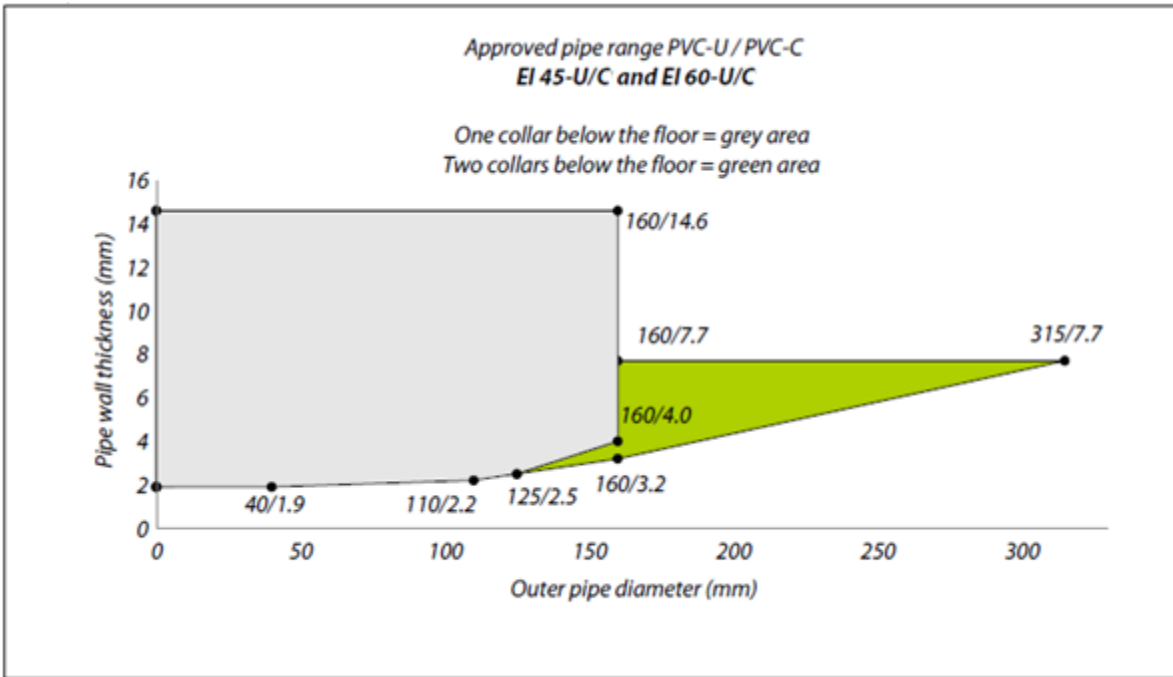
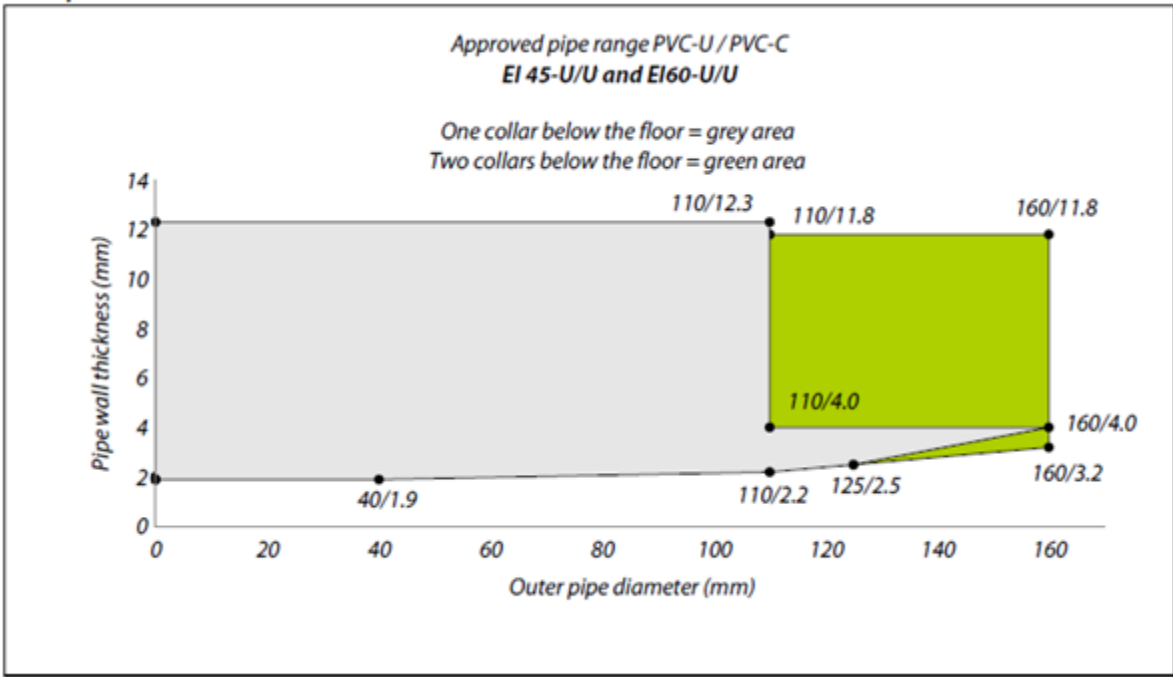

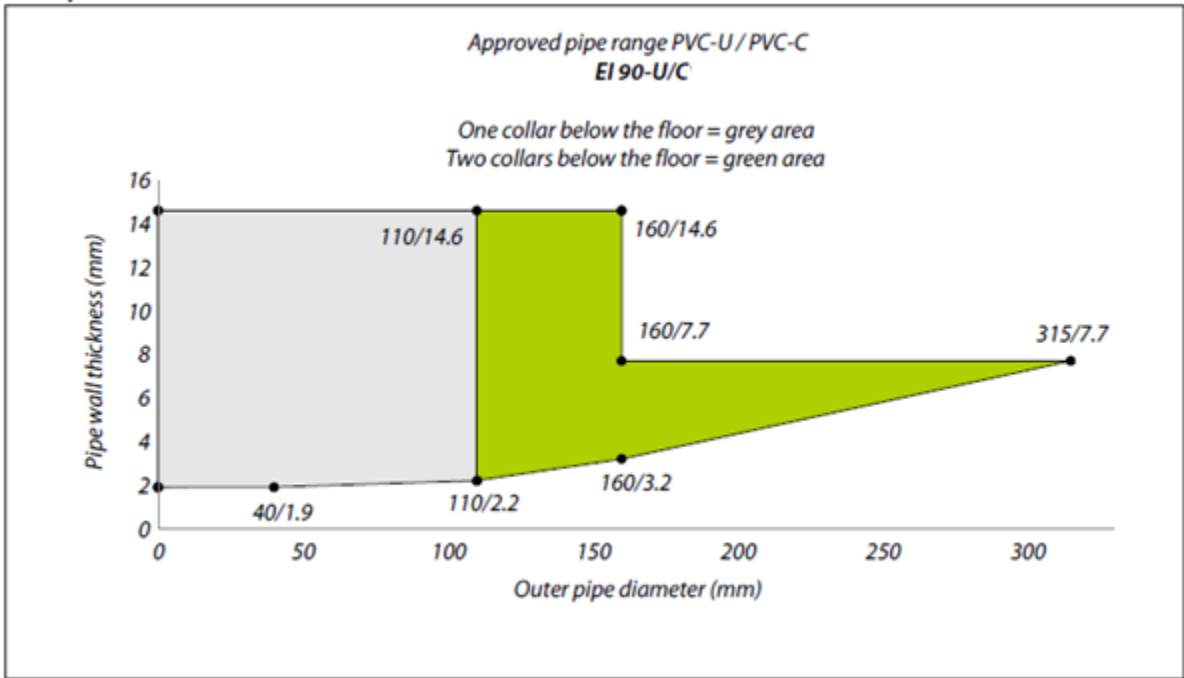
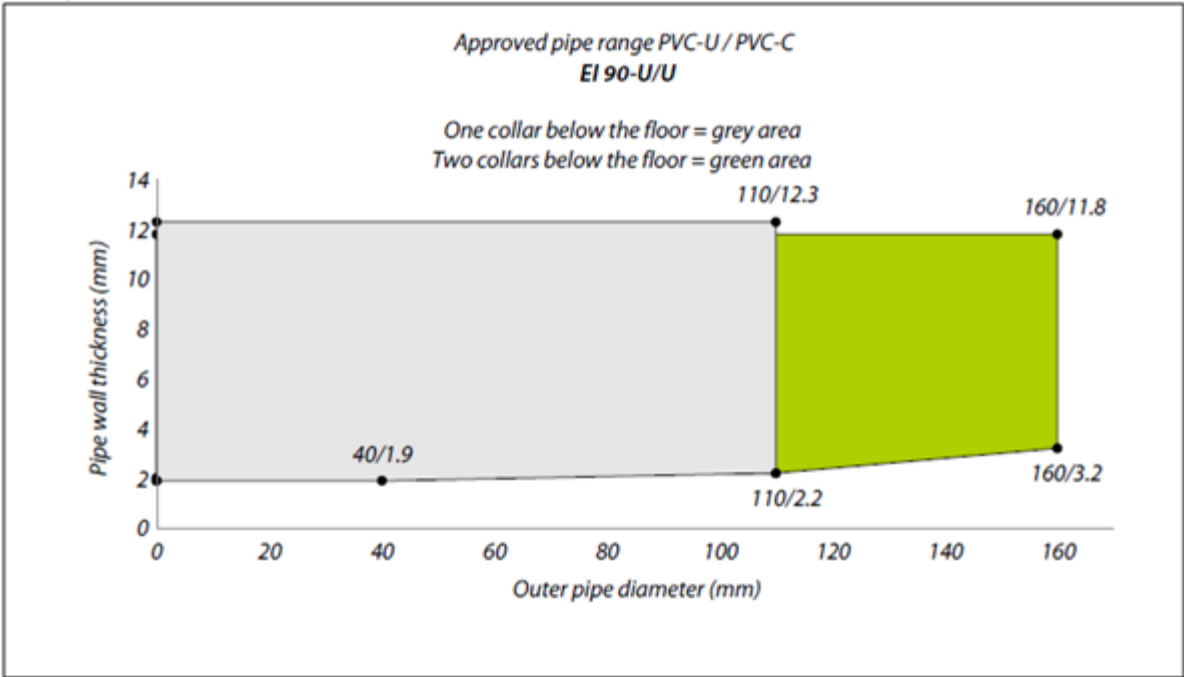

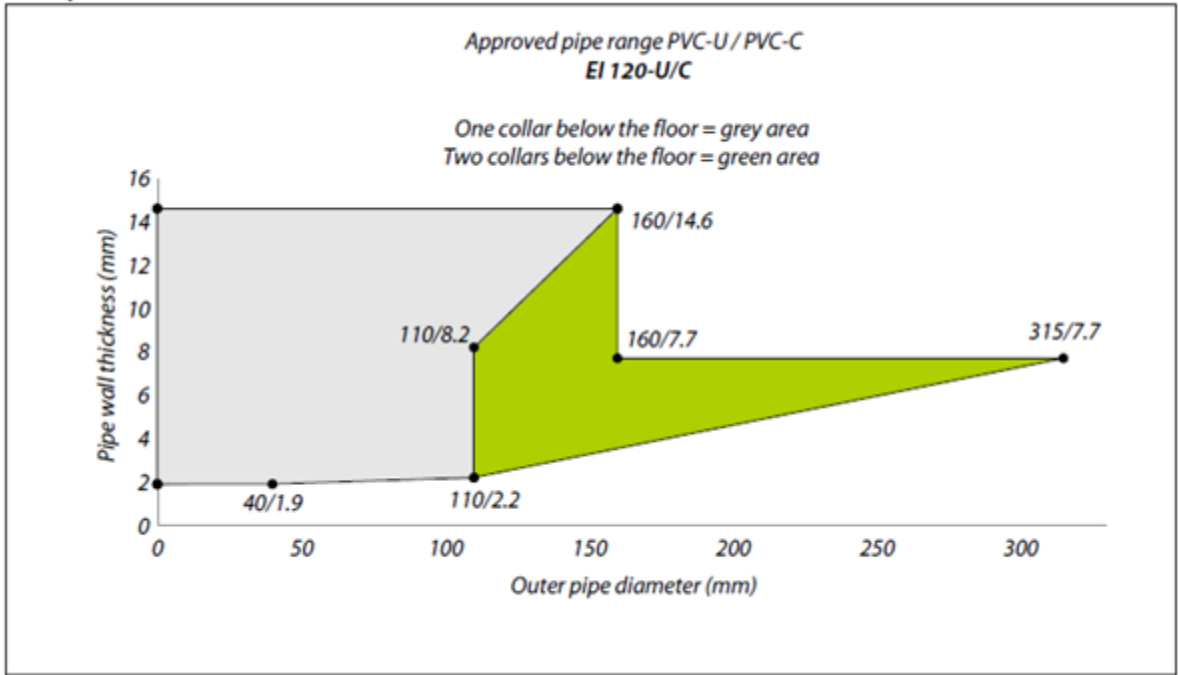
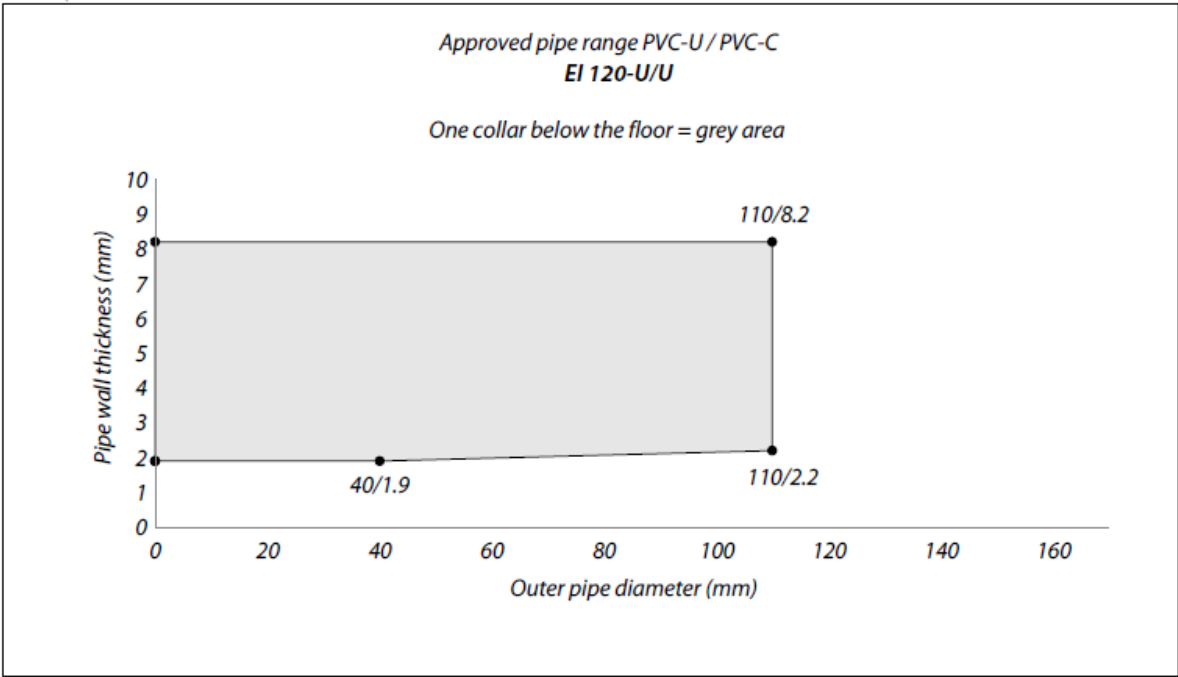

B.1.1.2 Plastic pipes fitted at angles 45°-90° to the floor, with one or two Mulcol® Multicollar Slim pipe collars to the soffit.

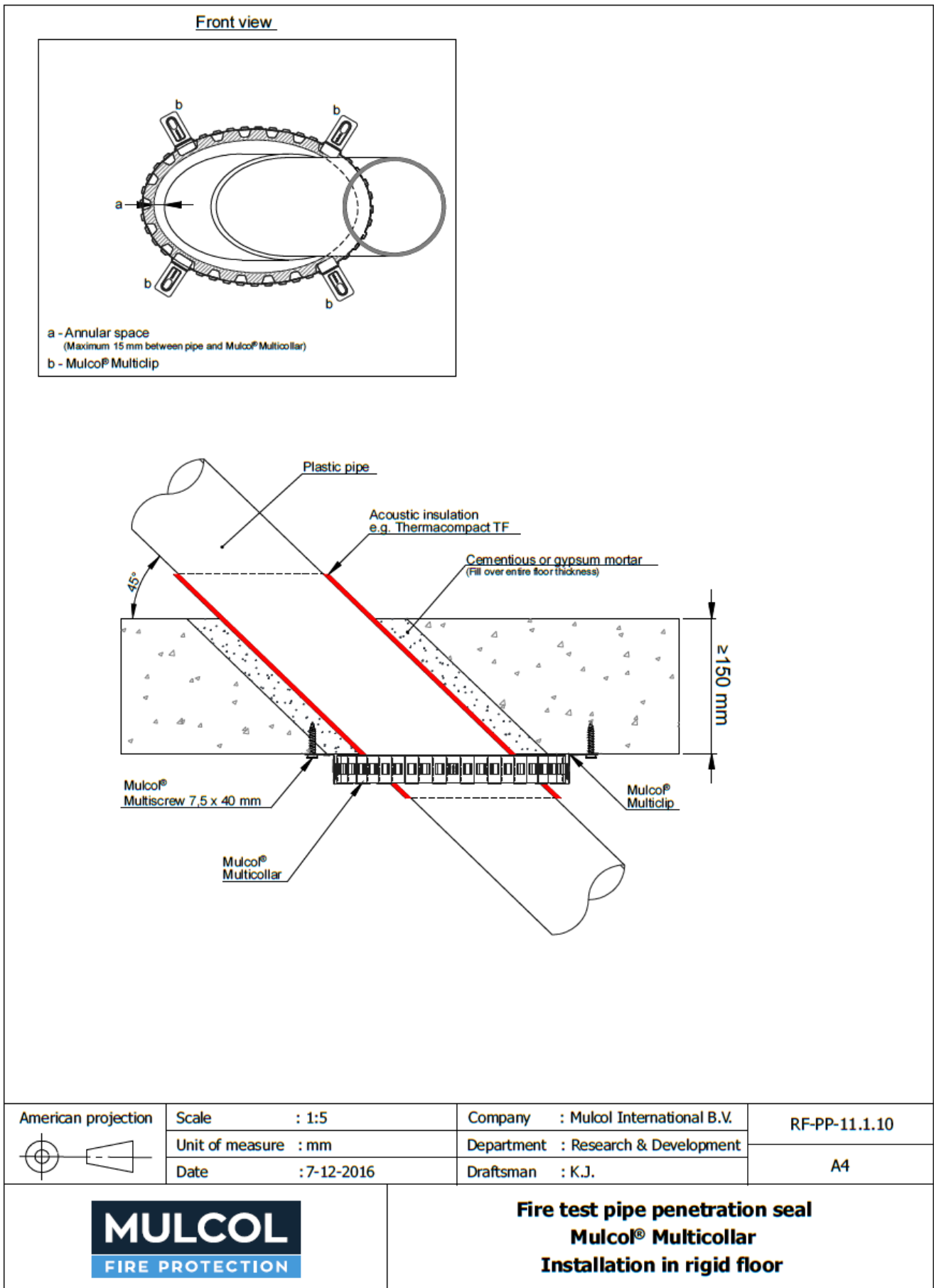

Front view

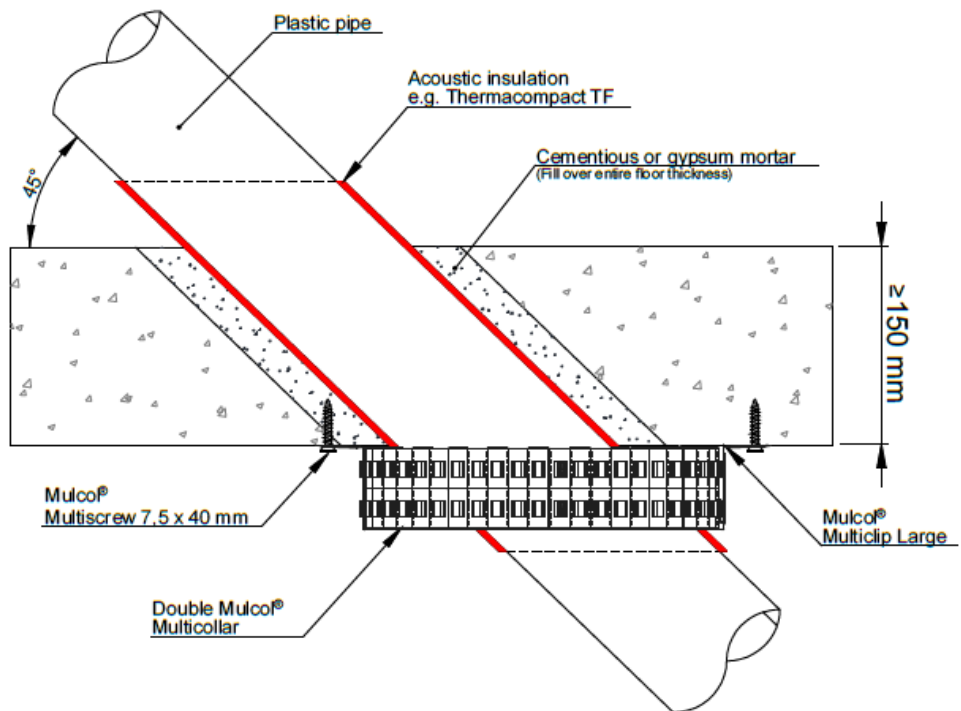
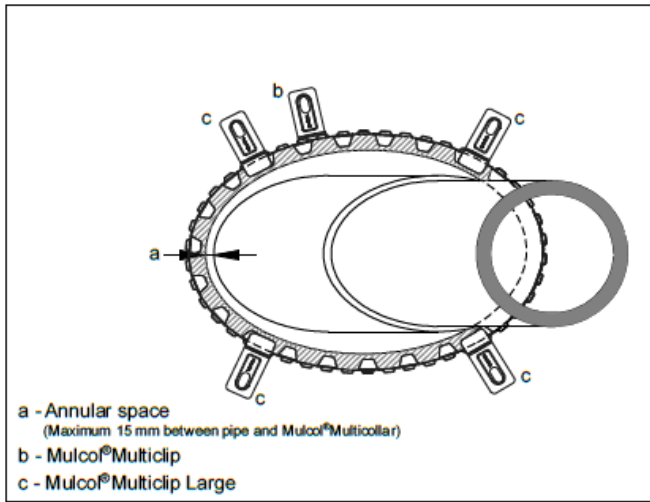

American projection

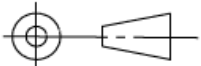

Scale : 1:5

Unit of measure : mm

Date : 7-12-2016

Company : Mulcol International B.V.

Department : Research & Development

Draftsman : K.J.

RF-PP-21.1.10

A4



Fire test pipe penetration seal
Mulcol® Multicollar
Installation in rigid floor

Pipe material [^]	Maximum pipe diameter mm	Pipe wall thickness mm	No. of collars per face	Classification*
PE-HD / PE / ABS / SAN+PVC	110	3.4	one	EI 60 U/U
		3.4-10.0	two	
		10.0		EI 90 U/U
PP		3.4		EI 120 U/U
		3.4-10.0		EI 90 U/U
PVC-U / PVC-C		3.4-10.0	EI 60 U/C	
	10.0	EI 90 U/C		

* U/U pipe end configuration applies to U/C, C/U and C/C also

[^] Pipes may optionally be fitted with up to 4 mm thick sound decoupling insulation, min. 50 mm long (LS/CS/LI/CI)

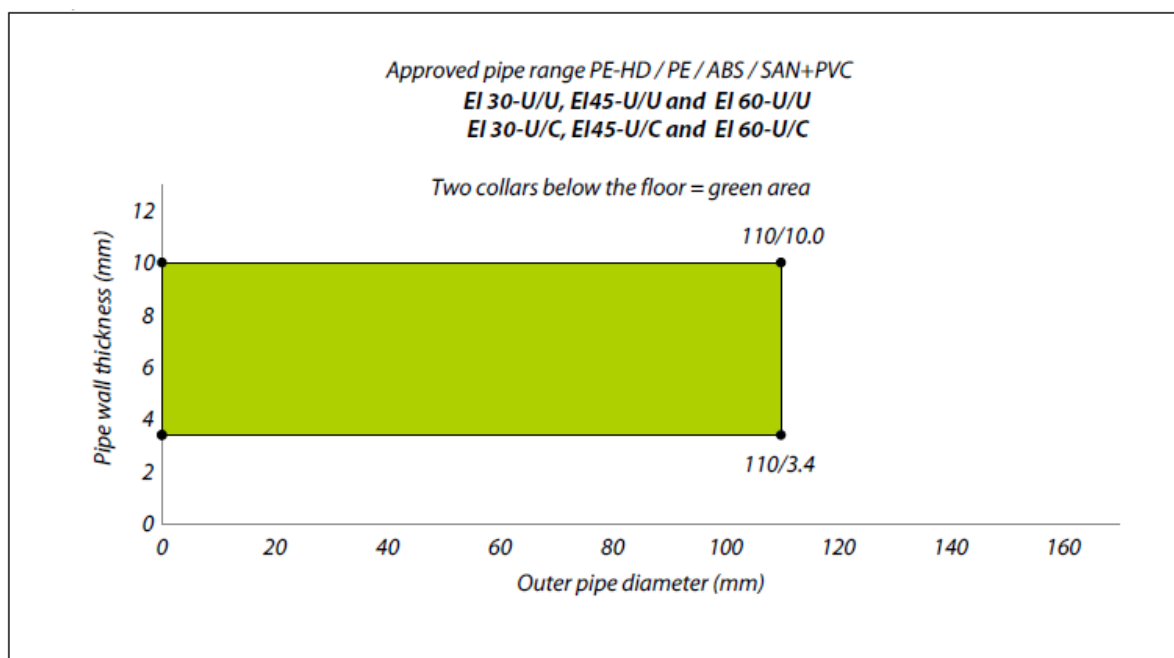

Approved pipe range PP
EI 30-U/U, EI45-U/U, EI 60-U/U and EI 90-U/U
EI 30-U/C, EI45-U/C, EI 60-U/C and EI 90-U/C

Two collars below the floor = green area

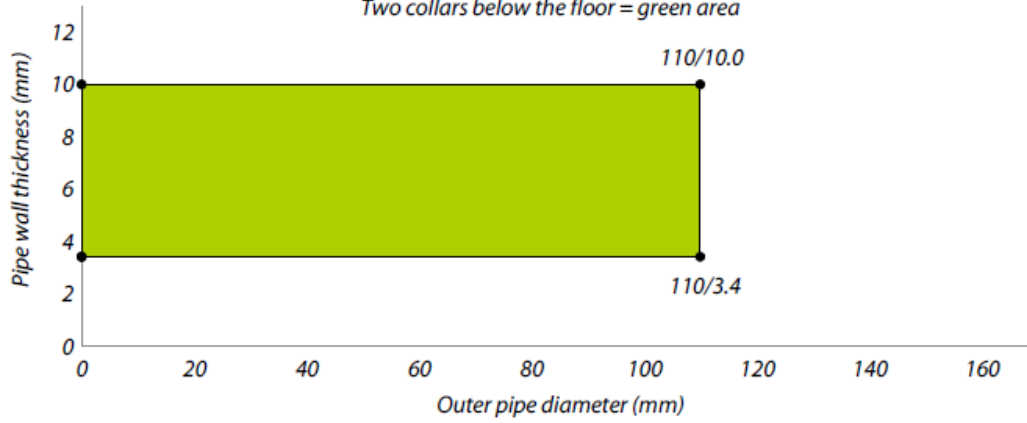

Approved pipe range PVC-U / PVC-C
EI 30-U/U, EI45-U/U and EI 60-U/U
EI 30-U/C, EI45-U/C and EI 60-U/C

Two collars below the floor = green area

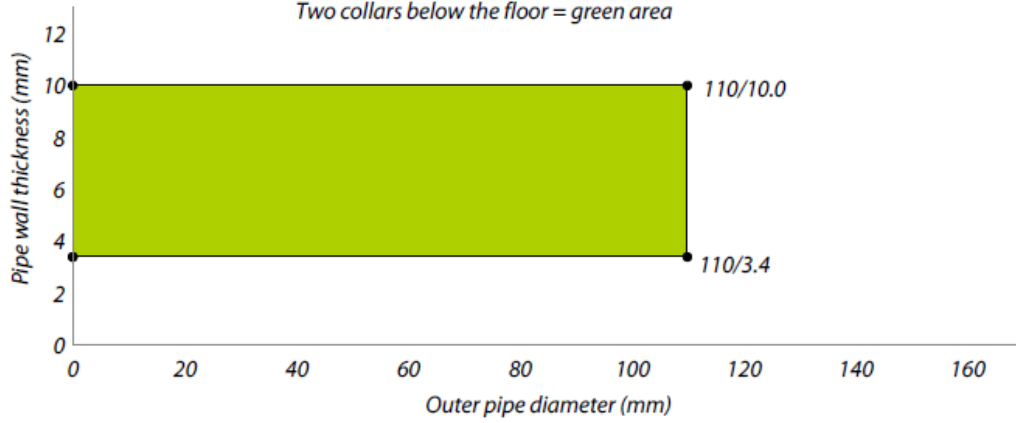

B.1.1.3 Plastic pipes, perpendicular to the floor, in Mulcol® Multimastic FB1 coated board seals , with one Mulcol® Multicollar Slim pipe collars to the soffit

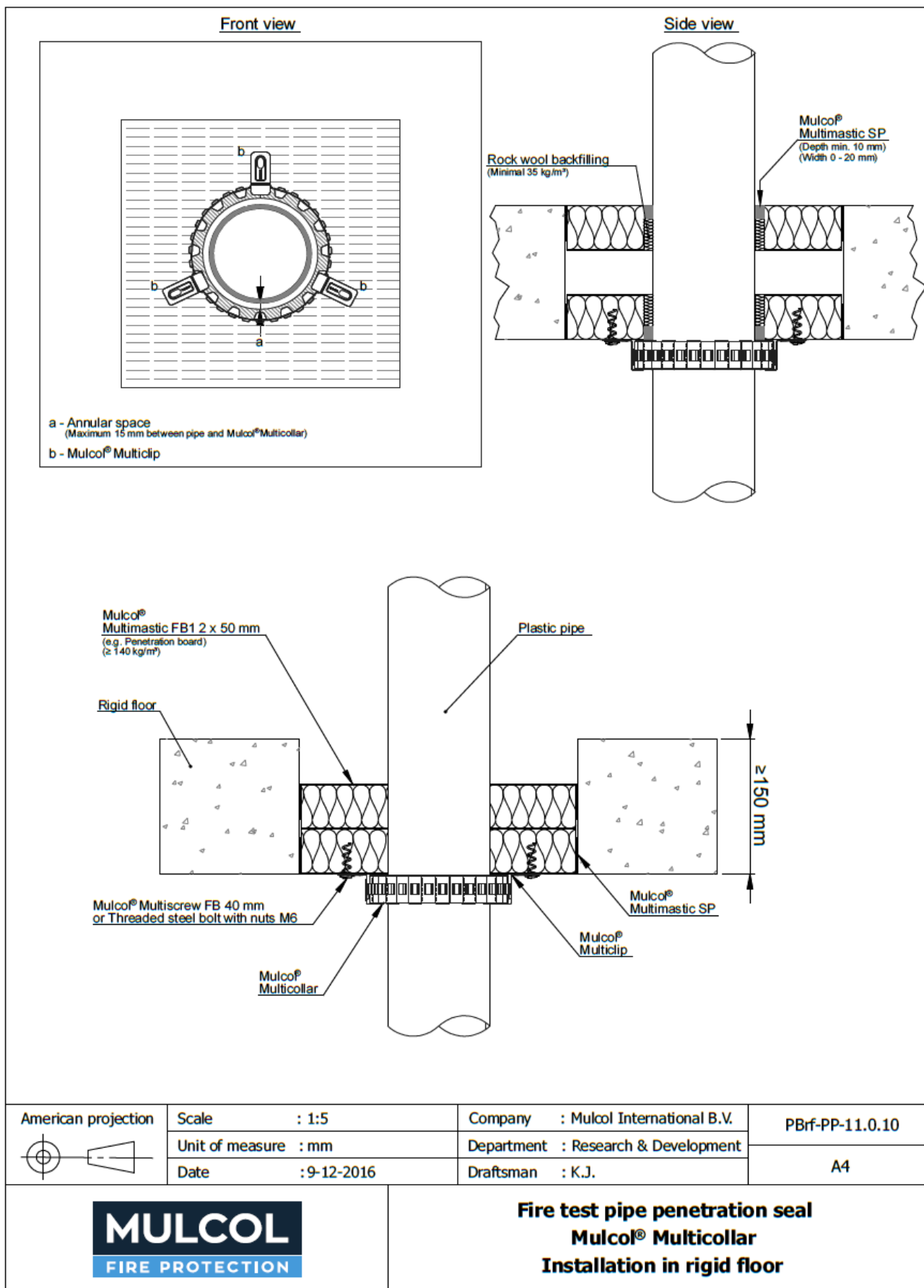

Pipe material	Maximum pipe diameter mm	Pipe wall thickness mm	No. of collars per face	Classification*
PE-HD / PE / ABS / SAN+PVC	110	2.7	one	EI 90 U/U
		2.7-6.6		EI 60 U/U
2.7		EI 90 U/U		
2.7-6.6		EI 60 U/U		
2.7		EI 90 U/U		
2.7-6.3		EI 60 U/U		
PP				
PVC-U / PVC-C				

* U/U pipe end configuration applies to U/C, C/U and C/C also

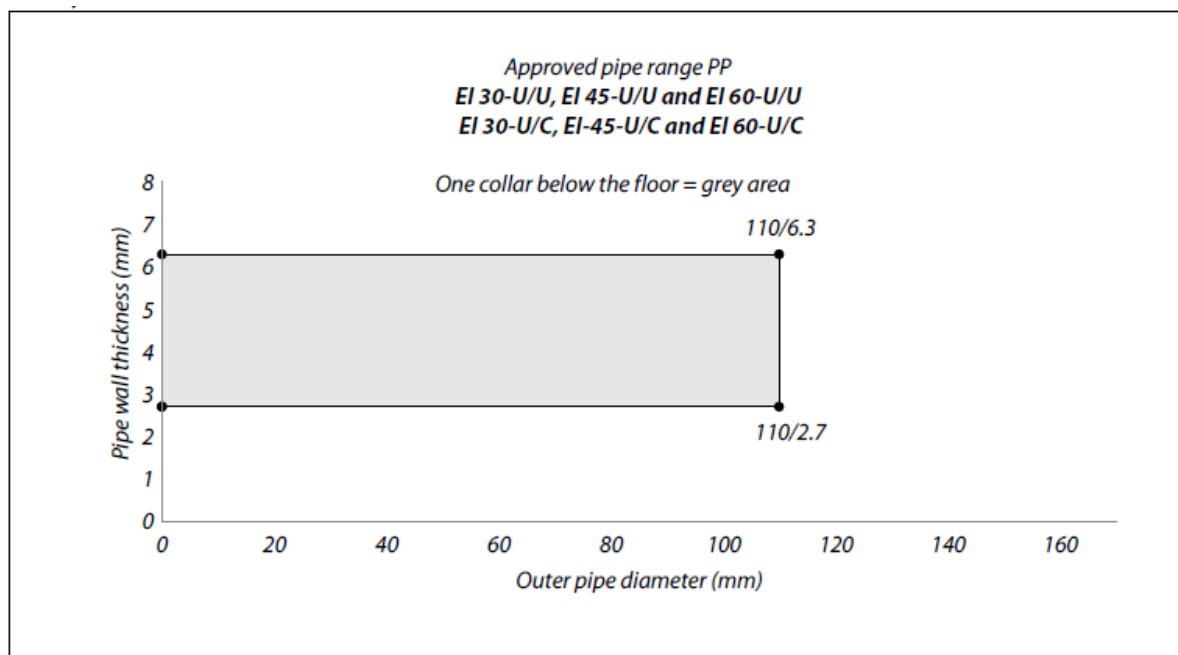
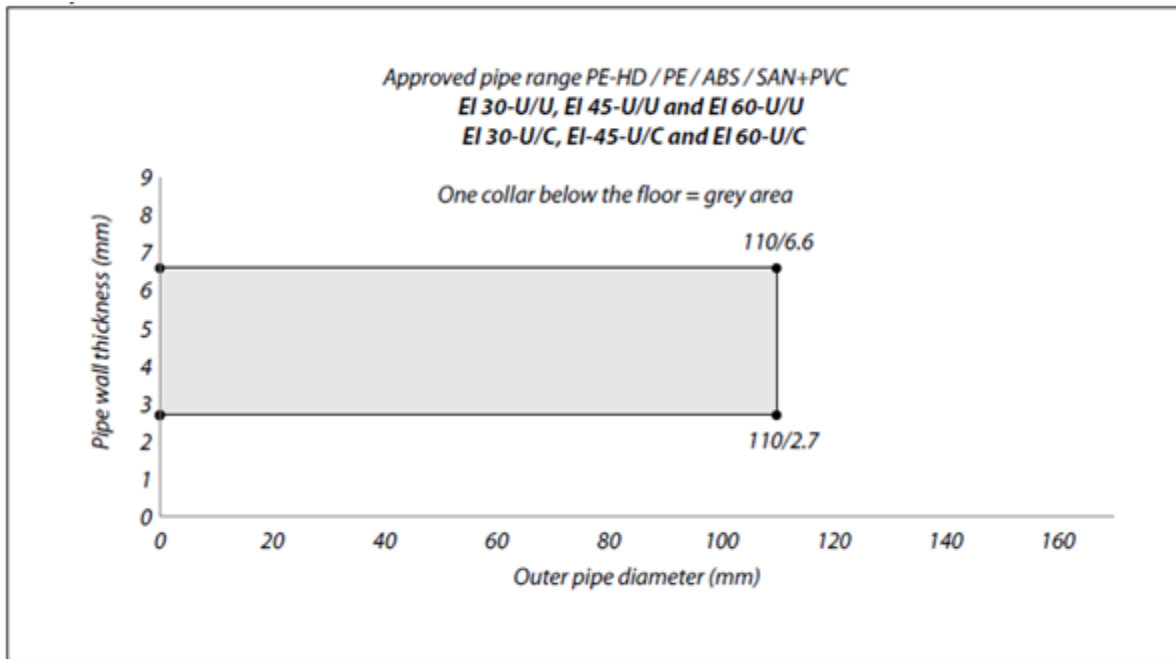

Approved pipe range PVC-U / PVC-C
EI 30-U/U, EI 45-U/U and EI 60-U/U
EI 30-U/C, EI-45-U/C and EI 60-U/C

One collar below the floor = grey area

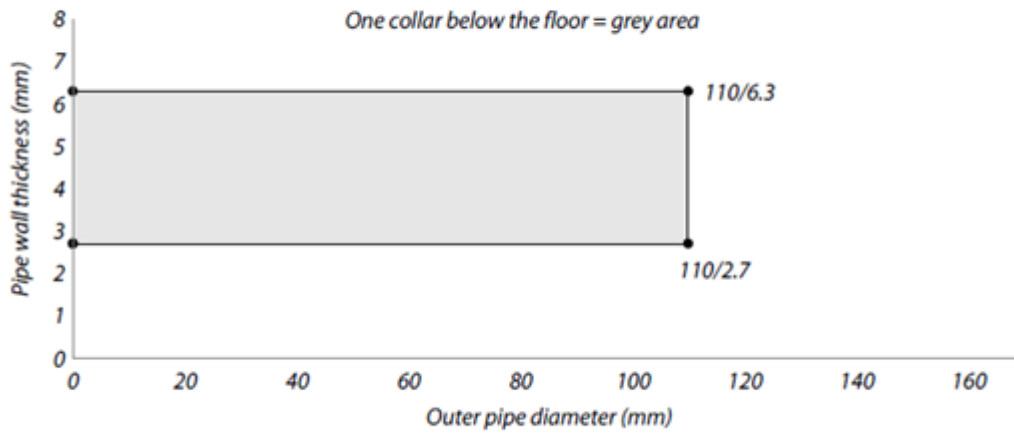

B.1.1.4 Plastic pipes insulated with AF/Armaflex made out of flexible elastomeric EPDM rubber foam with a min. reaction to fire class BL-s3, d0 or B-s3 or, d0 (to EN 13501-1), perpendicular to the floor, with two Mulcol® Multicollar Slim pipe collars to the soffit.

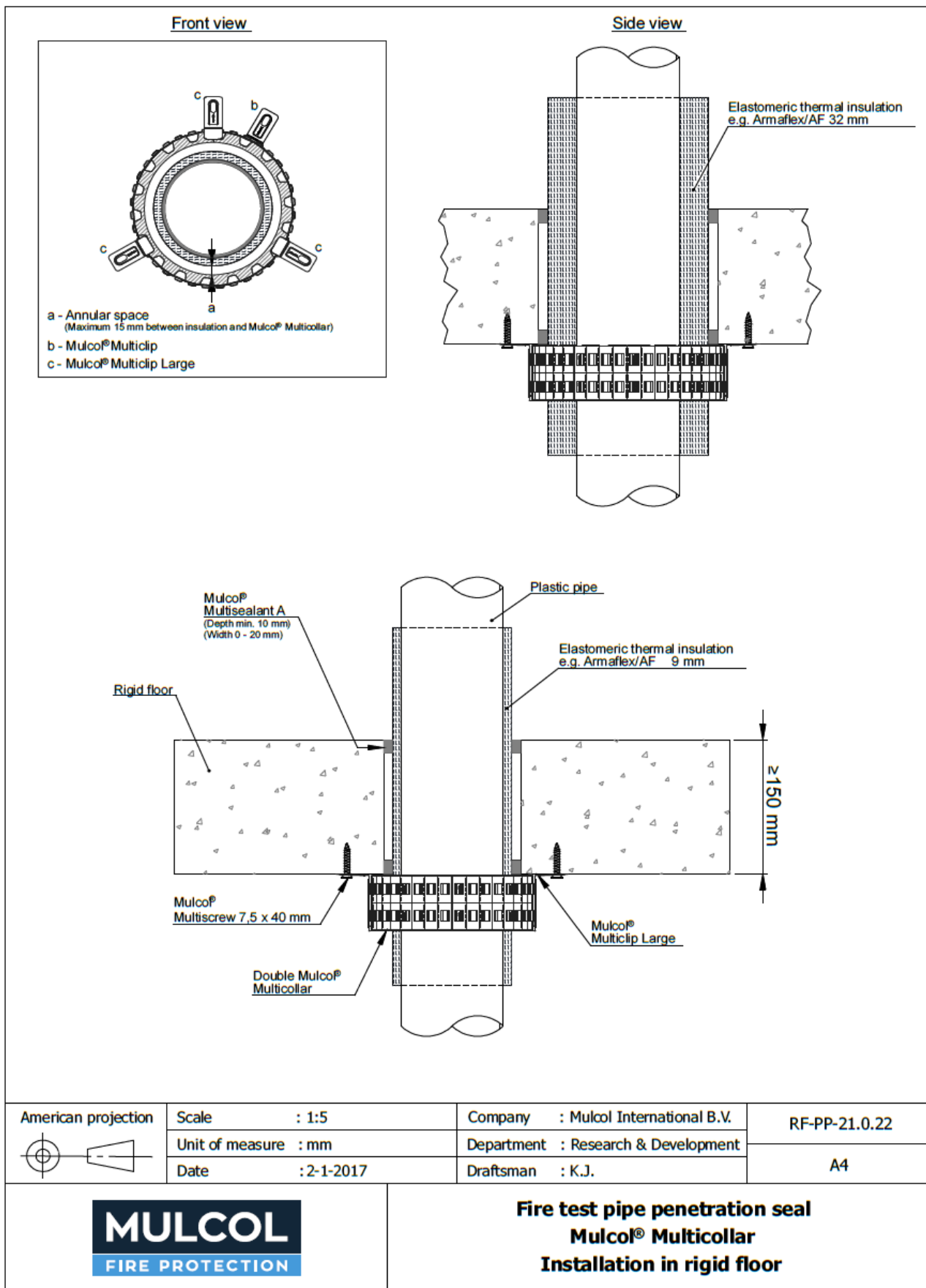

Pipe material [^]	Maximum pipe diameter mm	Pipe wall thickness mm	Insulation LS/CS/LI/CI thickness/ length mm	No. of collars per face	Classification*
PVC-U / PVC-C	110	3.2	9-32 / 450 (min.)	Two	EI 120 U/U

* U/U pipe end configuration applies to U/C, C/U and C/C also

B.1.2 Plastic pipes recessed into the soffit

B.1.2.1 Plastic pipes fitted perpendicular to the floor, with one Mulcol® Multicollar Slim pipe collar cast into the soffit

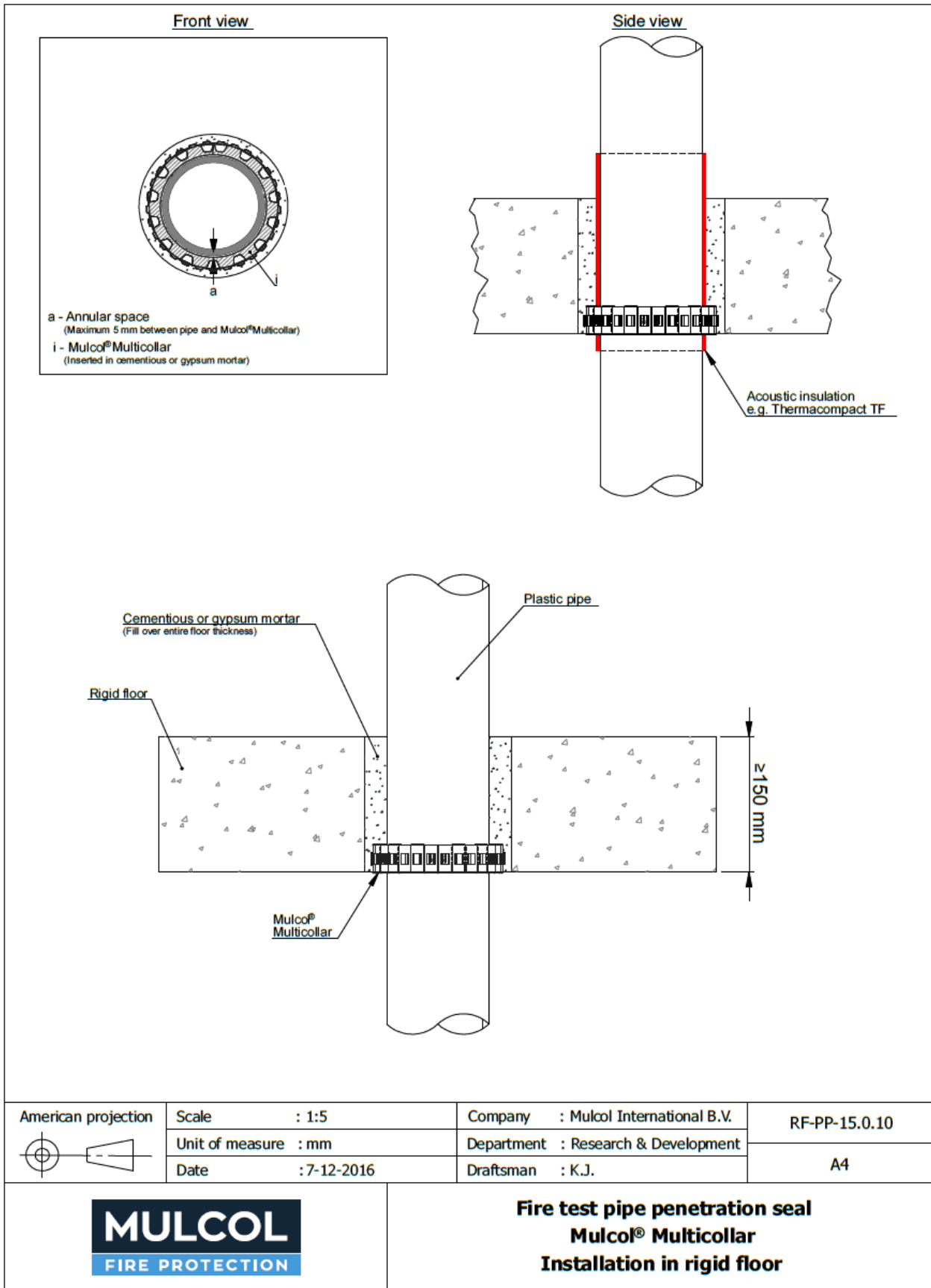

Pipe material[^]	Maximum pipe diameter mm	Pipe wall thickness mm	No. of collars per face	Classification*
PP	110	6.3	one	EI 30 U/U

* U/U pipe end configuration applies to U/C, C/U and C/C also

[^] Pipes may optionally be fitted with up to 4 mm thick sound decoupling insulation, min. 50 mm long (LS/CS/LI/CI)

B.1.3 Plastic pipes with an (electrofusion) pipe coupling

B.1.3.1 Plastic pipes with (electrofusion) pipe coupling fitted perpendicular to the floor, with one Mulcol® Multicollar Slim pipe collars to the soffit

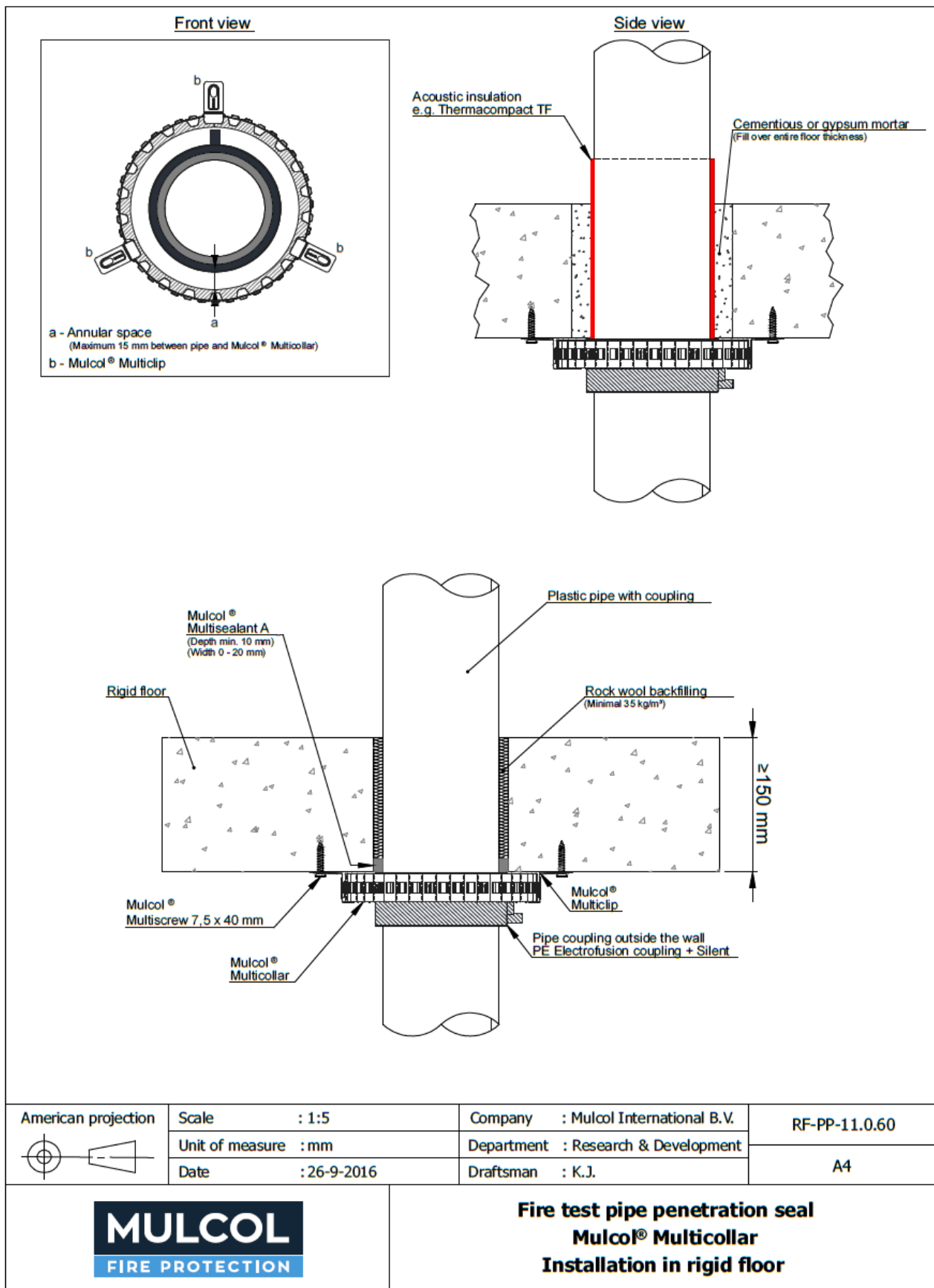

Pipe material [^]	Maximum pipe diameter mm	Pipe wall thickness mm	Type of coupling	Classification*
PE-HD / PE / ABS / SAN+PVC	110	4.3	Electric Geberit PE	EI 90 U/C
	125	7.4		EI 60 U/C

* U/C pipe end configuration applies to C/C also

[^] Pipes may optionally be fitted with up to 4 mm thick sound decoupling insulation, min. 50 mm long (LS/CS/LI/CI)

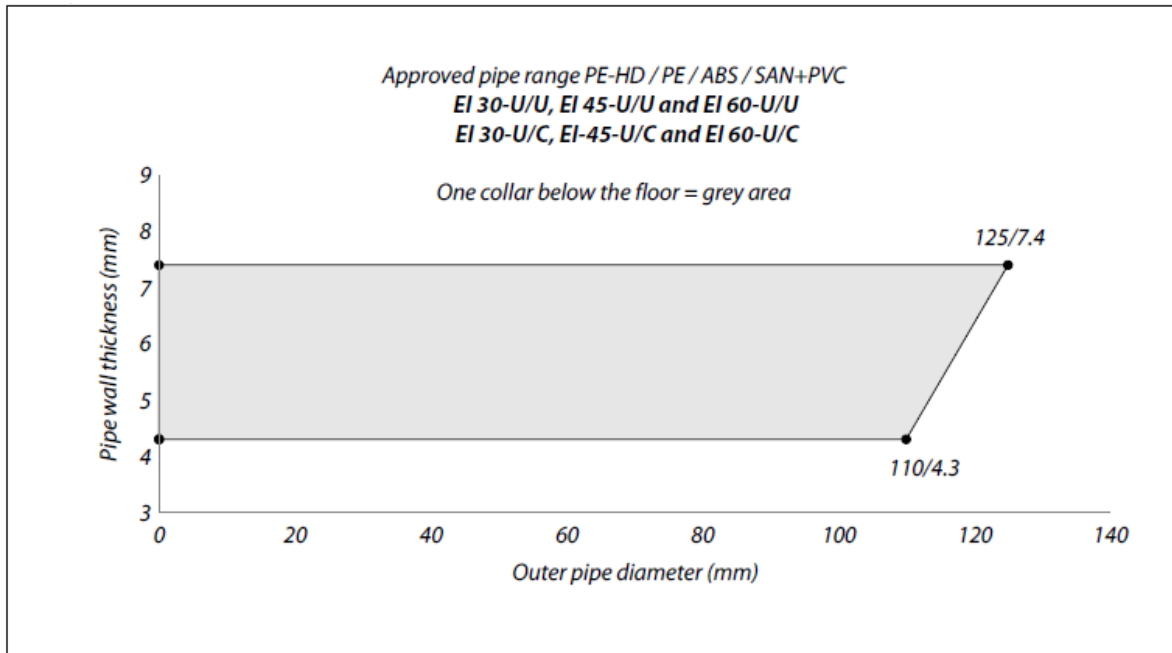

B.1.4 Plastic pipes with elbows

B.1.4.1 Plastic pipes with an elbow, perpendicular to the floor, with one Mulcol® Multicollar Slim pipe collar to the soffit in an 'U' shape

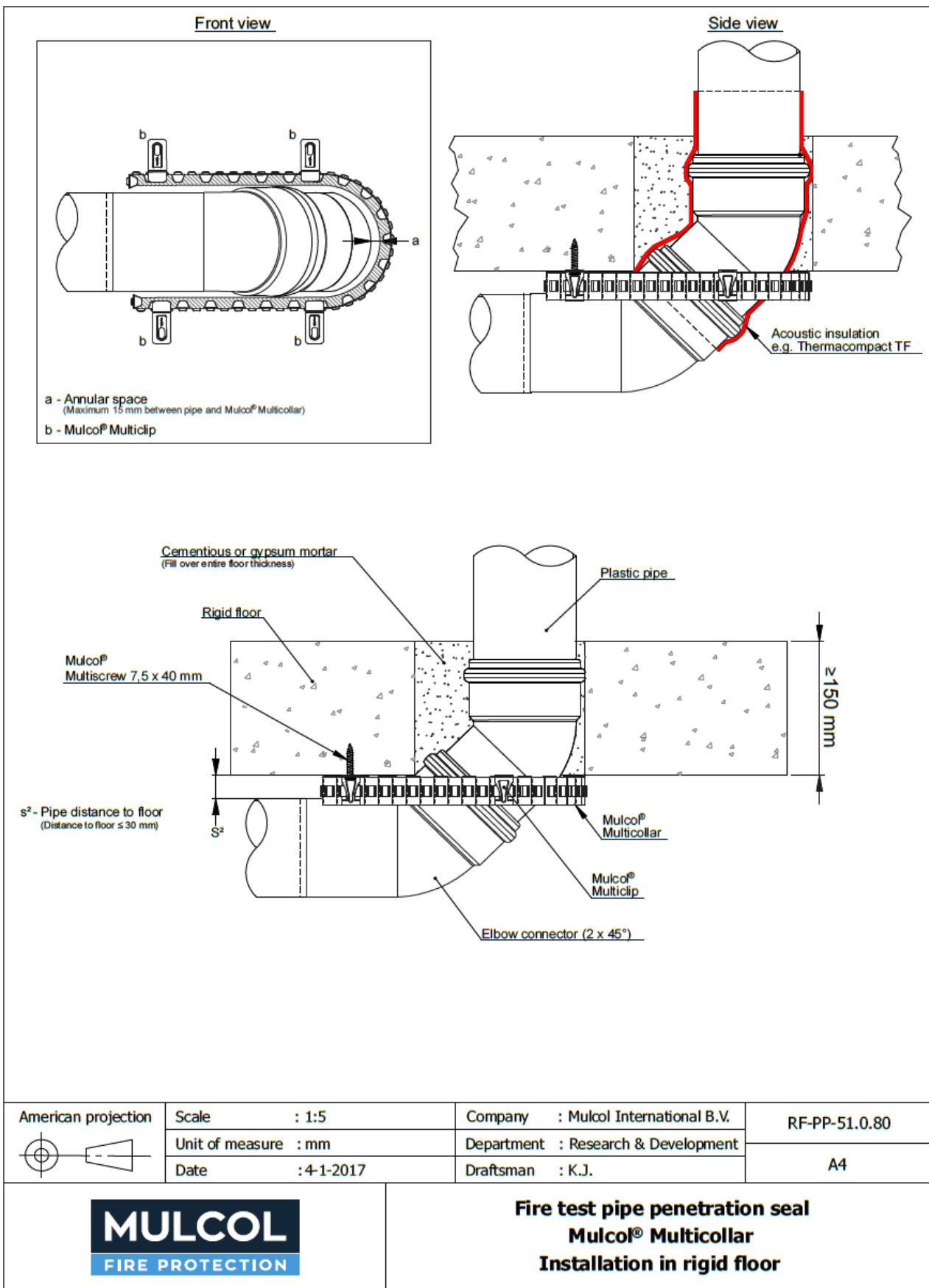

Pipe material [^]	Maximum pipe diameter mm	Pipe wall thickness mm	Elbow type	No. of collars per face	Classification*
PVC-U, PVC-C	50	3.0	PVC-U / PVC-C Ø50 mm 2x 45°	One	EI 90 U/U
	110	3.2	PVC-U / PVC-C Ø110 mm 2x 45°		E 60 U/U EI 45 U/U

* U/U pipe end configuration applies to U/C, C/U and C/C also

[^] Pipes may optionally be fitted with up to 4 mm thick sound decoupling insulation, min. 50 mm long (LS/CS/LI/CI)

B.1.5 Plastic pipes with zero distance to the wall

B.1.5.1 Plastic pipes, perpendicular to the floor, in floor corner, with one Mulcol® Multicollar Slim pipe collars to the soffit

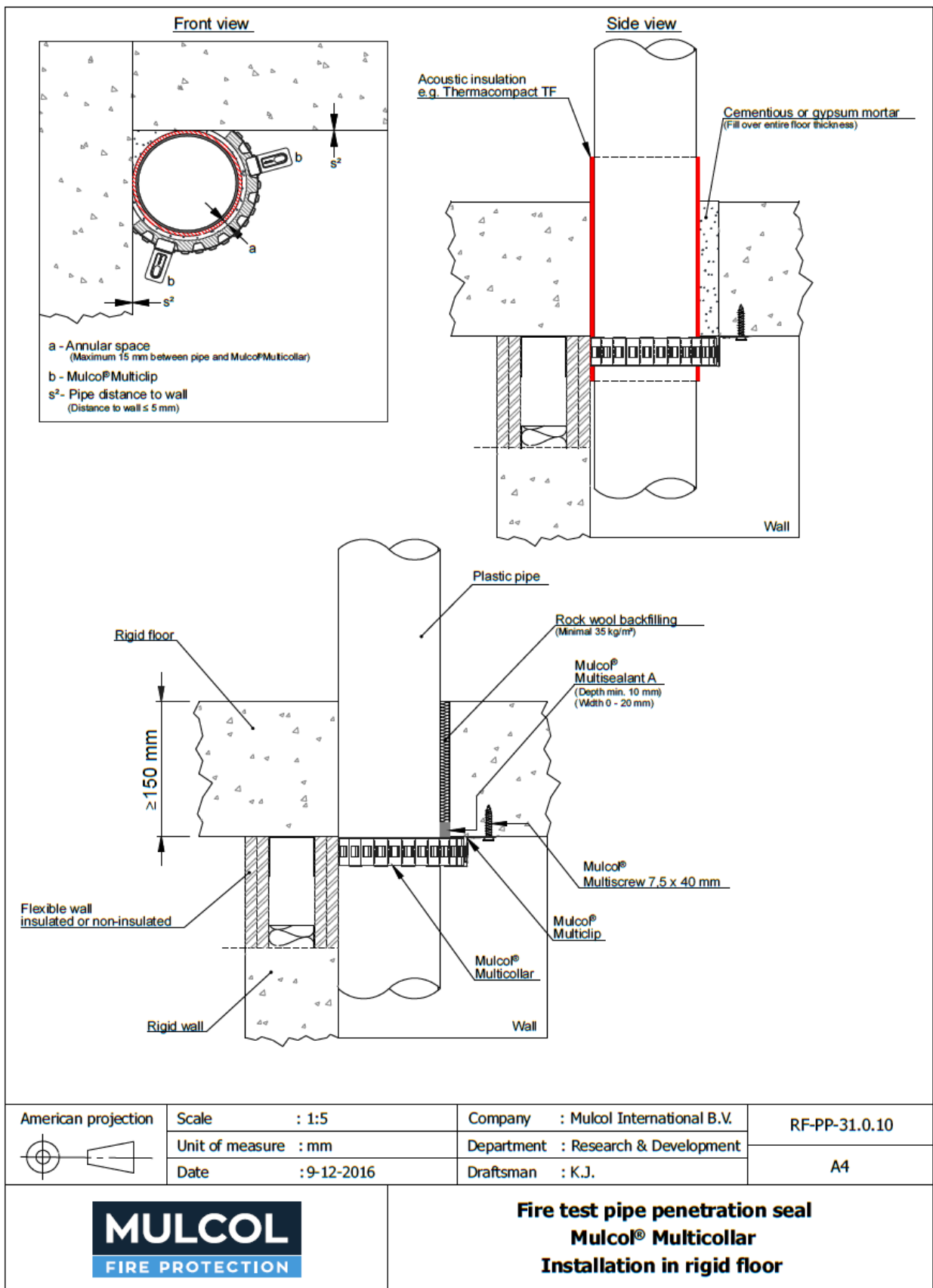

Pipe material [^]	Maximum pipe diameter mm	Pipe wall thickness mm	No. of collars	Location	Classification*
PE-HD / PE / ABS / SAN+PVC	110	6.6	one	In corner	EI 120 U/U
PP	110	6.3			EI 90 U/U
PVC-U / PVC-C	125	7.4			EI 60 U/C

* U/U pipe end configuration applies to U/C, C/U and C/C also

[^] Pipes may optionally be fitted with up to 4 mm thick sound decoupling insulation, min. 50 mm long (LS/CS/LI/CI)

B.2 Plastic pipes (Silent)

B.2.1 Plastic pipes (Silent) in regular configurations

B.2.1.1 Plastic pipes (silent), perpendicular to the floor, with one or two Mulcol® Multicollar Slim pipe collars to the soffit.

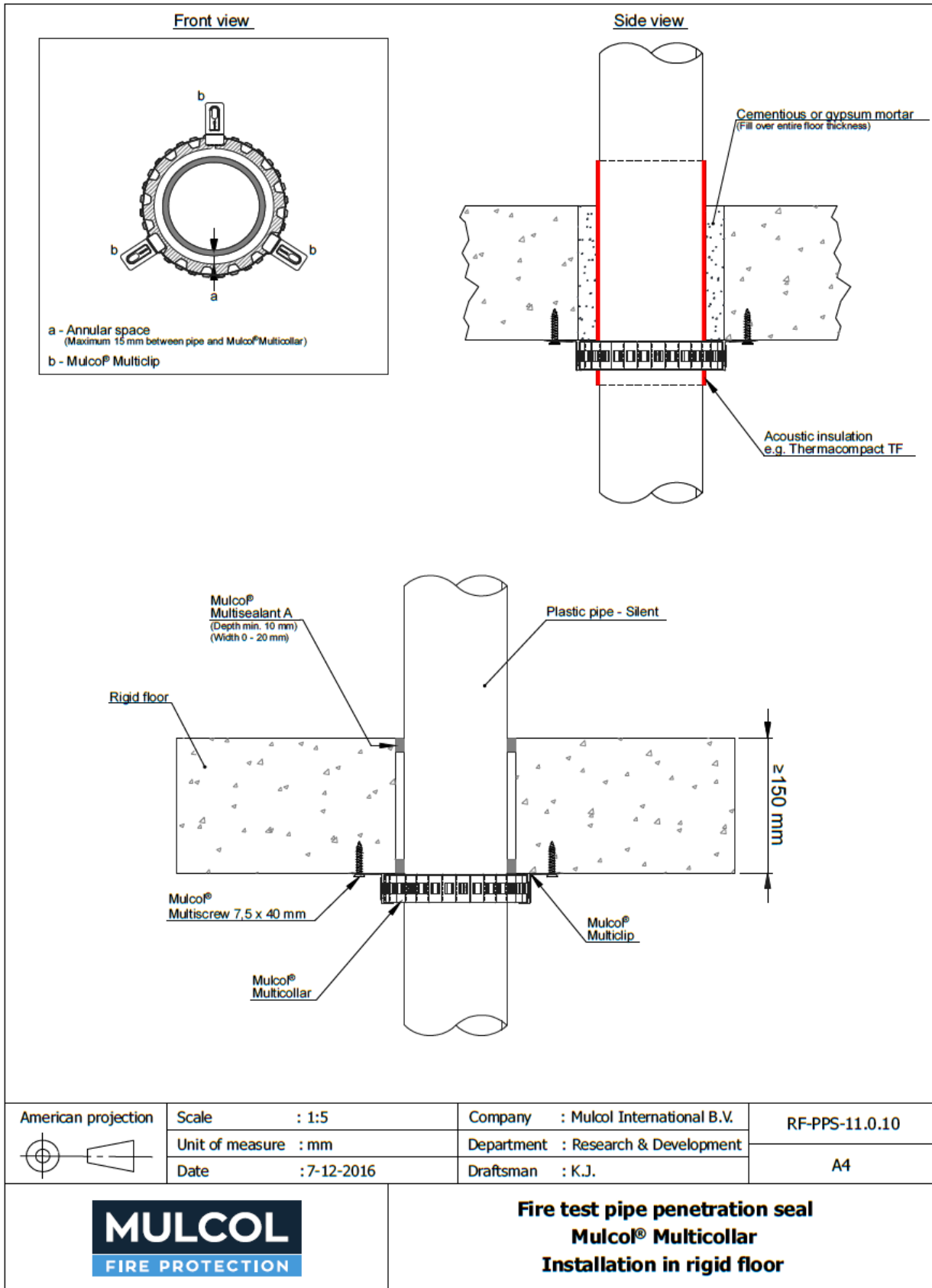

Pipe material [^]	Maximum pipe diameter mm	Pipe wall thickness mm	No. of collars per face	Classification*
Raupiano Plus	50	1.8-4.0	one	EI 120 U/U
	110	2.7-4.0		
	160	4.0		
Geberit Silent dB 20	56	3.2-7.0		
	110	6.0-7.0		
	160	7.0		
Wavin SiTech+	110	3.6		

* U/U pipe end configuration applies to U/C, C/U and C/C also

[^] Pipes may optionally be fitted with up to 4 mm thick sound decoupling insulation, min. 50 mm long (LS/CS/LI/CI)

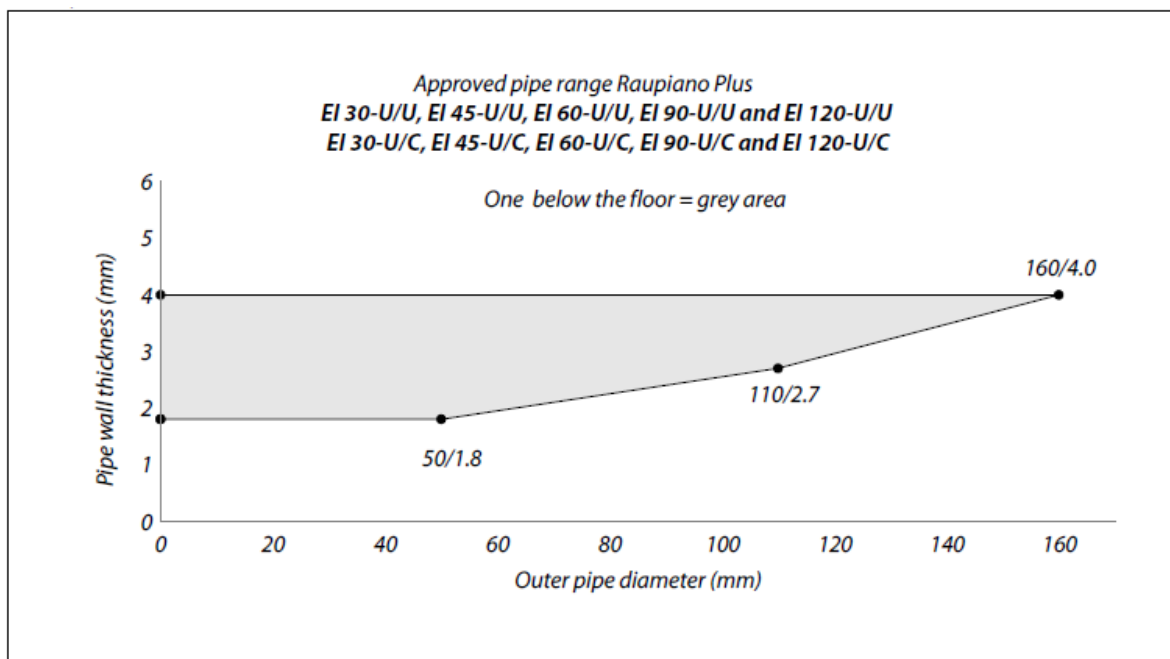

Approved pipe range Geberit Silent dB 20
EI 30-U/U, EI 45-U/U, EI 60-U/U, EI 90-U/U and EI 120-U/U
EI 30-U/C, EI 45-U/C, EI 60-U/C, EI 90-U/C and EI 120-U/C

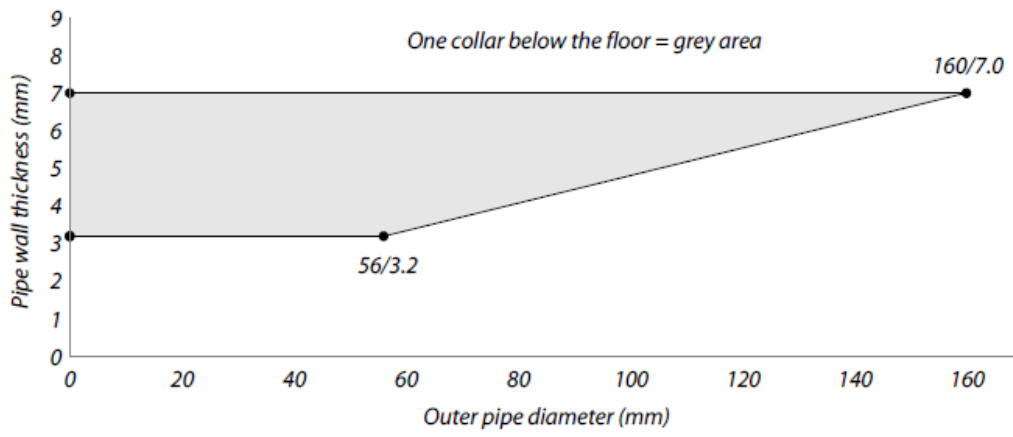

B.2.1.2 Plastic pipes (silent) fitted at angles 45°-90° to the floor, with two Mulcol® Multicollar *Slim* pipe collars to the soffit.

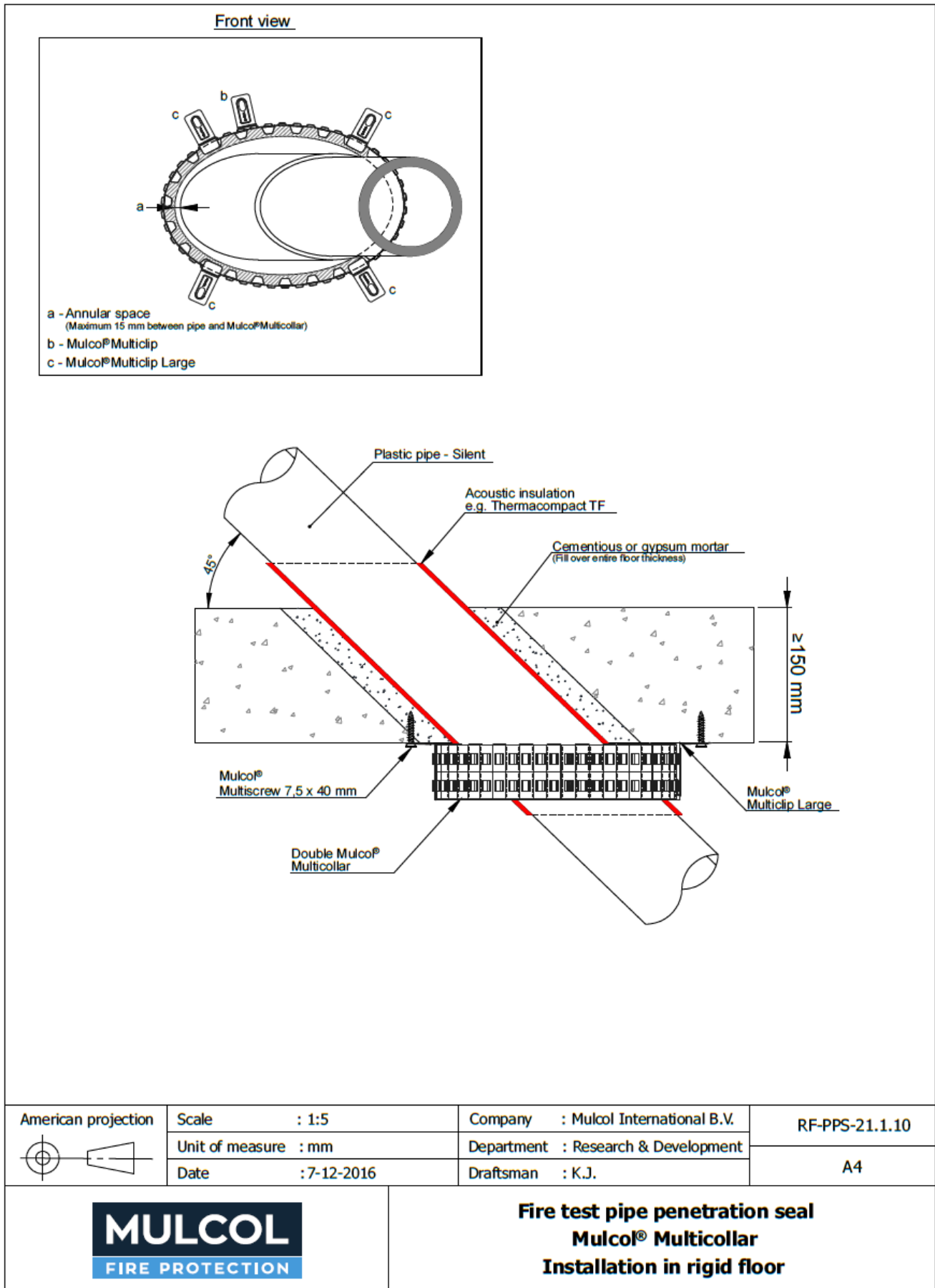

Pipe material [^]	Maximum pipe diameter mm	Pipe wall thickness mm	No. of collars per face	Classification*
Geberit Silent dB 20	110	6.0	two	EI 120 U/U

* U/U pipe end configuration applies to U/C, C/U and C/C also

[^] Pipes may optionally be fitted with up to 4 mm thick sound decoupling insulation, min. 50 mm long (LS/CS/LI/CI)

B.2.1.3 Plastic pipes (silent), perpendicular to the floor, in Mulcol® Multimastic FB1 coated board seals, with one Mulcol® Multicollar Slim pipe collars to the soffit

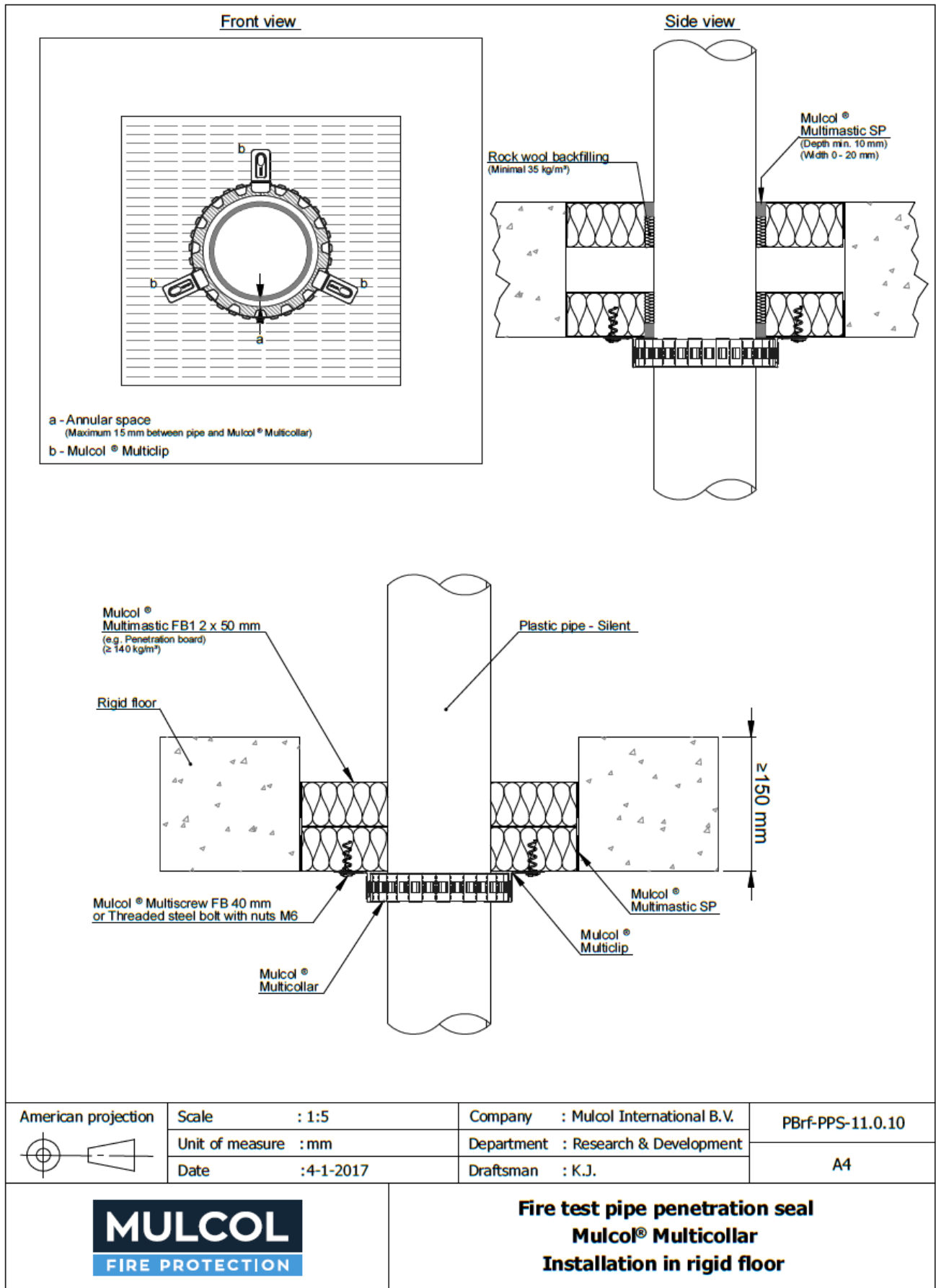

Pipe material	Maximum pipe diameter mm	Pipe wall thickness mm	No. of collars per face	Classification*
Geberit Silent dB 20	110	6.0	one	EI 90 U/U

* U/U pipe end configuration applies to U/C, C/U and C/C also

B.2.2 Plastic pipes (Silent) with moulded socket or expansion pipe coupling

B.2.2.1 Plastic pipes (silent) with moulded socket or expansion pipe coupling, perpendicular to the floor, with one Mulcol® Multicollar Slim pipe collar to the soffit

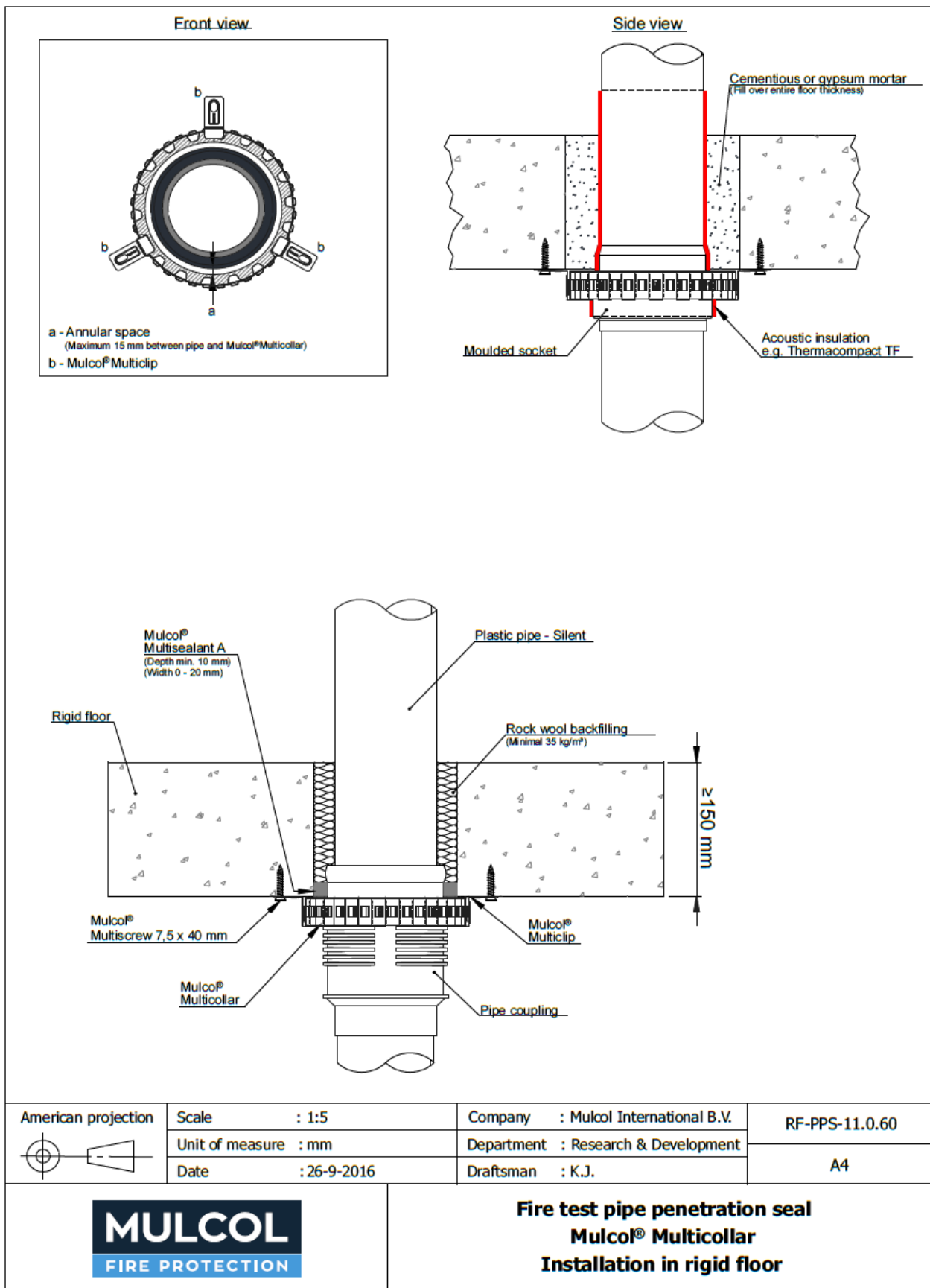

Pipe material [^]	Maximum pipe diameter mm	Pipe wall thickness mm	Type of coupling	No. of collars per face	Classification*
Geberit Silent dB 20	110	6.0	Geberit Silent dB 20 Ø110 mm expansion coupling	One	EI 120 U/C
Raupiano Plus		2.7	Raupiano Plus Ø110 mm Moulded socket		EI 120 U/U
Wavin SiTech+		3.6	Wavin SiTech+ Ø110 mm socket		

* U/U pipe end configuration applies to U/C, C/U and C/C also

[^] Pipes may optionally be fitted with up to 4 mm thick sound decoupling insulation, min. 50 mm long (LS/CS/LI/CI)

B.2.3 Plastic pipes (Silent) with an elbow

B.2.3.1 Plastic pipes (silent) with an elbow, perpendicular to the floor, with one Mulcol® Multicollar Slim pipe collar to the soffit

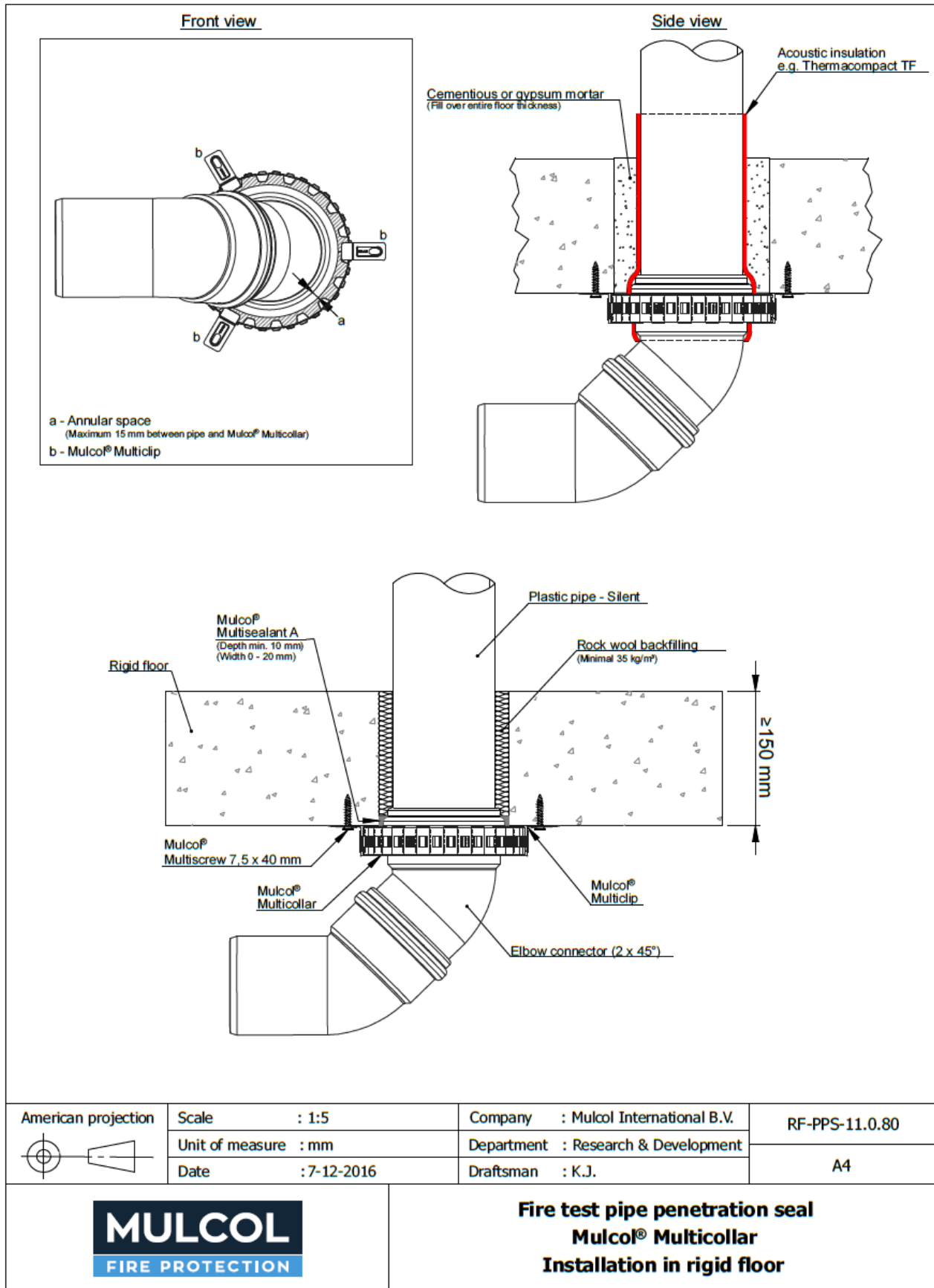

Pipe material [^]	Maximum pipe diameter mm	Pipe wall thickness mm	Type of elbow	No. of collars per face	Classification*
Wavin AS (PP)	110	5.3	Wavin AS PP Ø110 mm 2x 45°	One	EI 120 U/U
Geberit Silent dB 20		6.0	Geberit Silent dB 20 Ø110 mm 2x 45°		EI 90 U/U

* U/U pipe end configuration applies to U/C, C/U and C/C also

[^] Pipes may optionally be fitted with up to 4 mm thick sound decoupling insulation, min. 50 mm long (LS/CS/LI/CI)

B.2.3.2 Plastic pipes (silent) with an elbow, perpendicular to the floor, with one Mulcol® Multicollar Slim pipe collar to the soffit in an 'U' shape.

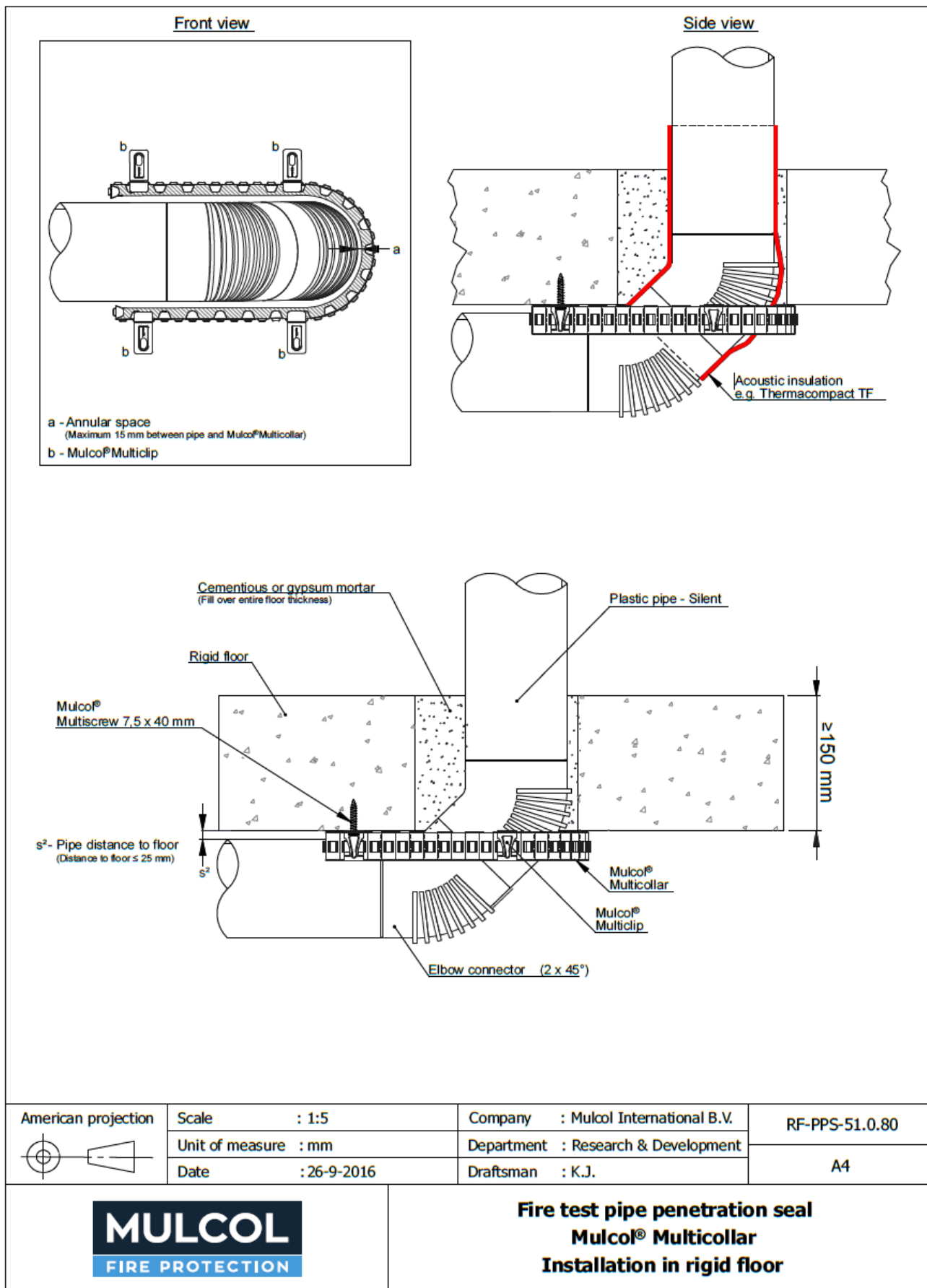

Pipe material [^]	Maximum pipe diameter mm	Pipe wall thickness mm	Type of elbow	No. of collars per face	Classification*
Geberit Silent dB 20	110	6.0	Geberit Silent dB 20 Ø110 mm 2x 45°	One	EI 90 U/U

* U/U pipe end configuration applies to U/C, C/U and C/C also

[^] Pipes may optionally be fitted with up to 4 mm thick sound decoupling insulation, min. 50 mm long (LS/CS/LI/CI)

B.2.4 Plastic Pipes (Silent) with zero distance to the wall

B.2.4.1 Plastic pipes (silent), perpendicular to the floor, in floor corner, with one Mulcol® Multicollar Slim pipe collars to the soffit.

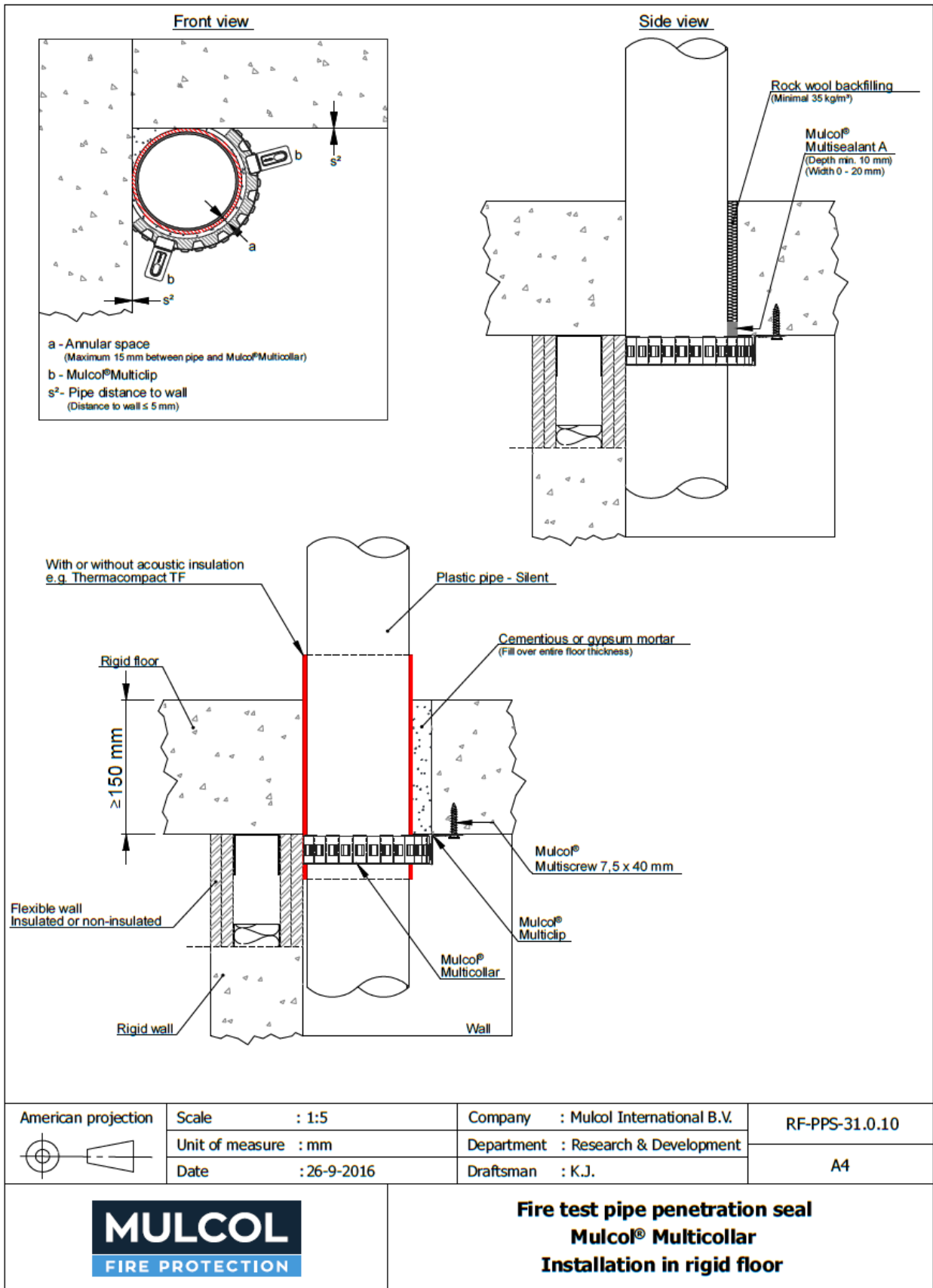

Pipe material [^]	Maximum pipe diameter mm	Pipe wall thickness mm	No. of collars per face	Location	Classification [*]
Geberit Silent dB 20	110	6.0	one	In corner	EI 120 U/C

* U/C pipe end configuration applies to C/C also

[^] Pipes may optionally be fitted with up to 4 mm thick sound decoupling insulation, min. 50 mm long (LS/CS/LI/CI)

B.3 PP-R multilayer pipes

B.3.1 PP-R multilayer pipes in regular configurations

B.3.1.1 PP-R multilayer pipes, perpendicular to the floor, with one or two Mulco® Multicollar Slim pipe collars to the soffit.

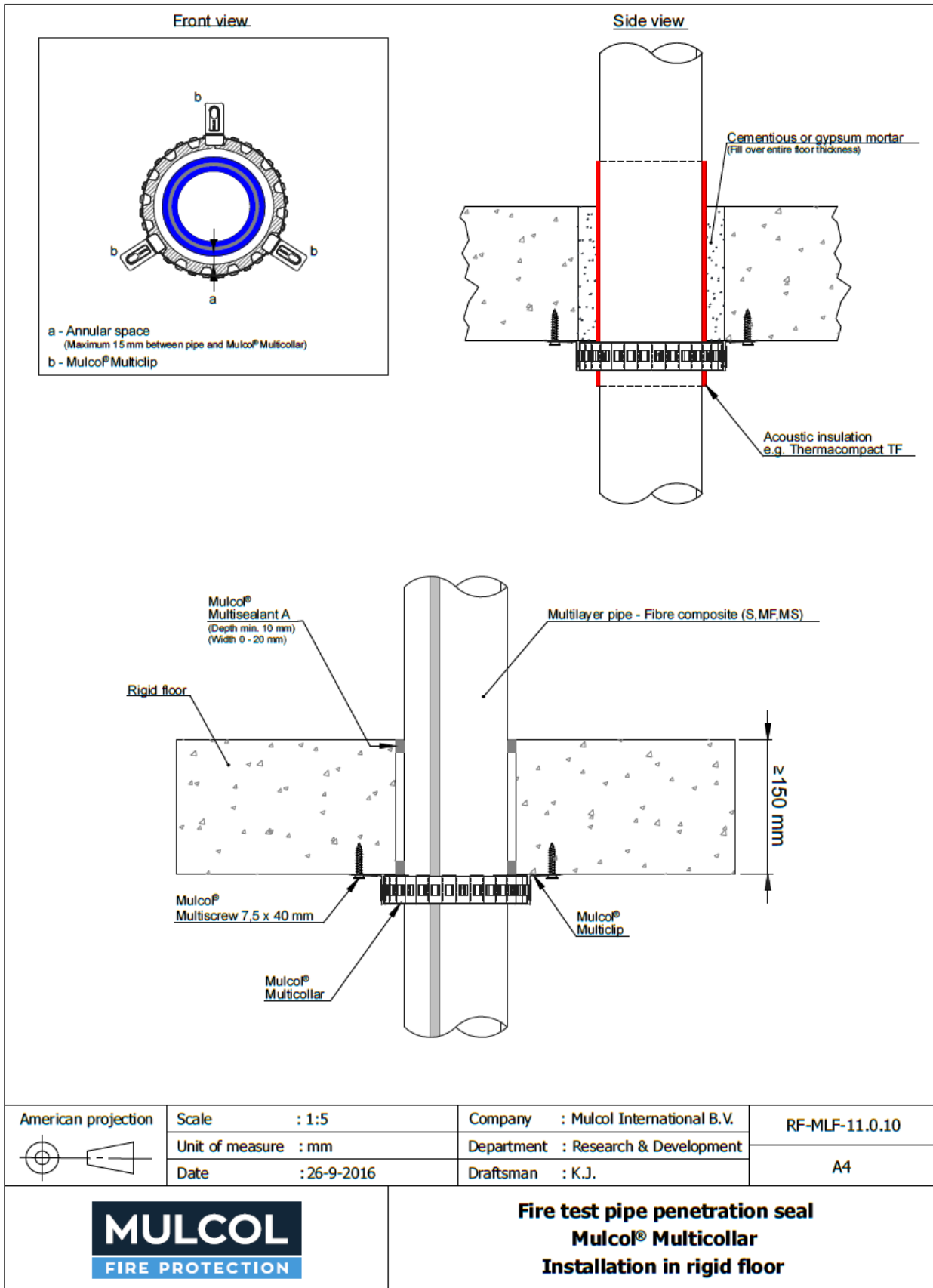

Front view

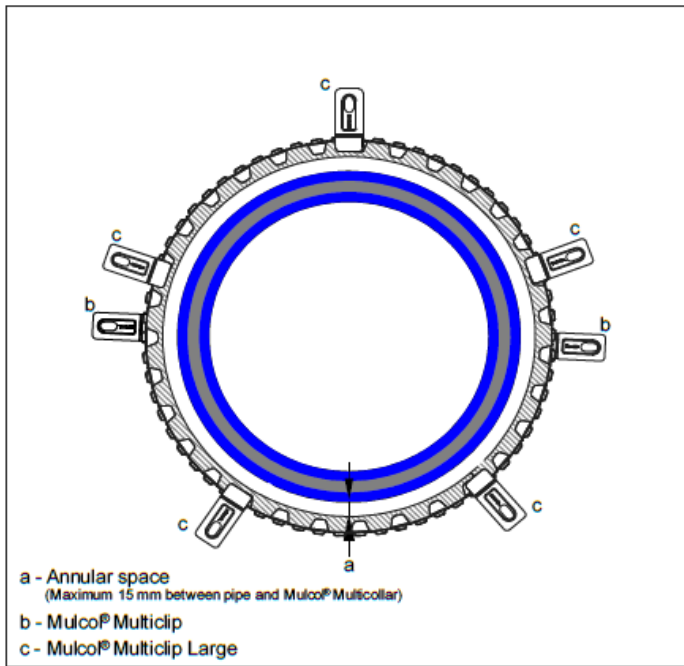

Side view

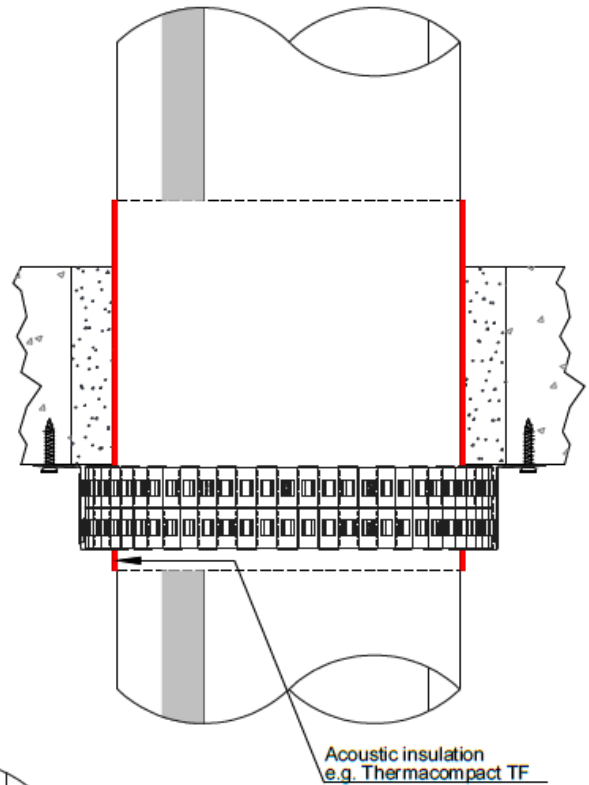

Cementious or gypsum mortar
(Fill over entire floor thickness)

Rigid floor

Mulco®
Multiscrew 7,5 x 40 mm

Double Mulco®
Multicollar

Multilayer pipe - Fibre composite (S,M,F,MS)

≥150 mm

Mulco®
Multiclip Large

American projection

Scale : 1:5

Company : Mulcol International B.V.

RF-MLF-21.0.10

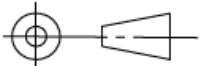

Unit of measure : mm

Department : Research & Development

Date : 8-12-2016

Draftsman : K.J.

A4



Fire test pipe penetration seal
Mulcol® Multicollar
Installation in rigid floor

Pipe material [^]	Maximum pipe diameter mm	Pipe wall thickness mm	No. of collars per face	Classification*
Aquatherm Blue-MF	20	2.8	one	EI 120 U/C
	110	10.0-14.6		EI 90 U/C
	160	14.6		EI 120 U/C
Aquatherm Red-MF	110	15.1		EI 120 U/C
Aquatherm Blue-MF	250	22.7	two	EI 120 U/C

* U/C pipe end configuration applies to C/C also

[^] Pipes may optionally be fitted with up to 4 mm thick sound decoupling insulation, min. 50 mm long (LS/CS/LI/CI)

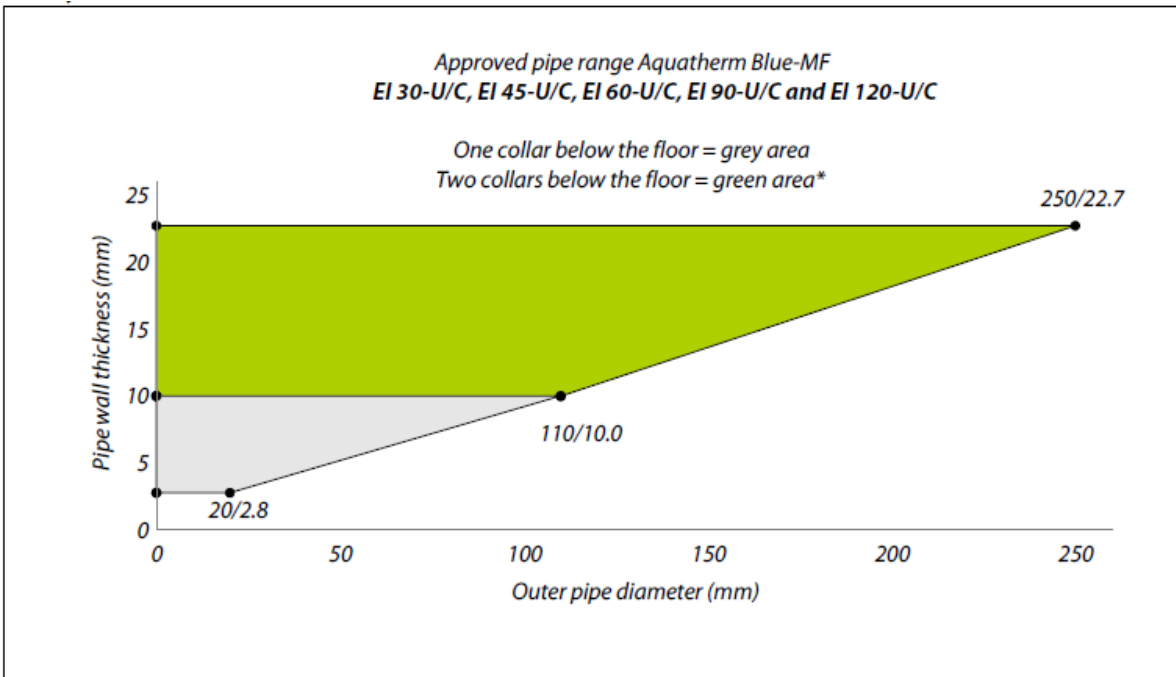
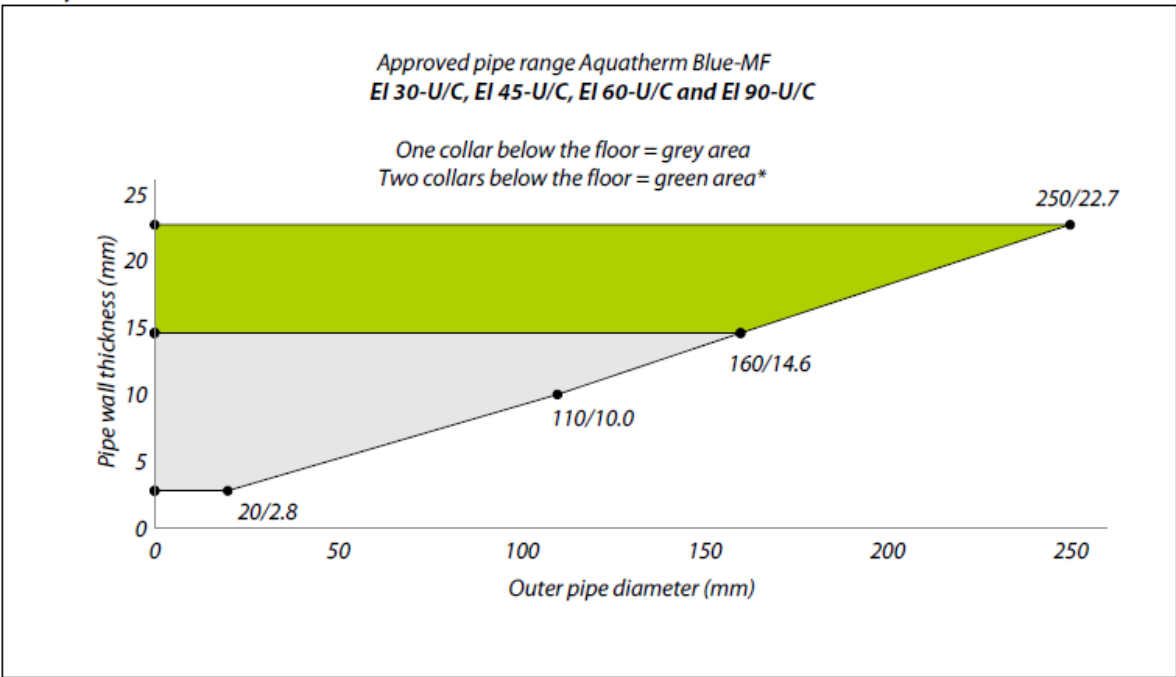

B.3.1.2 PP-R multilayer pipes, perpendicular to the floor, in Mulcol® Multimastic FB1 coated board seals, with one Mulcol® Multicollar Slim pipe collars to the soffit.

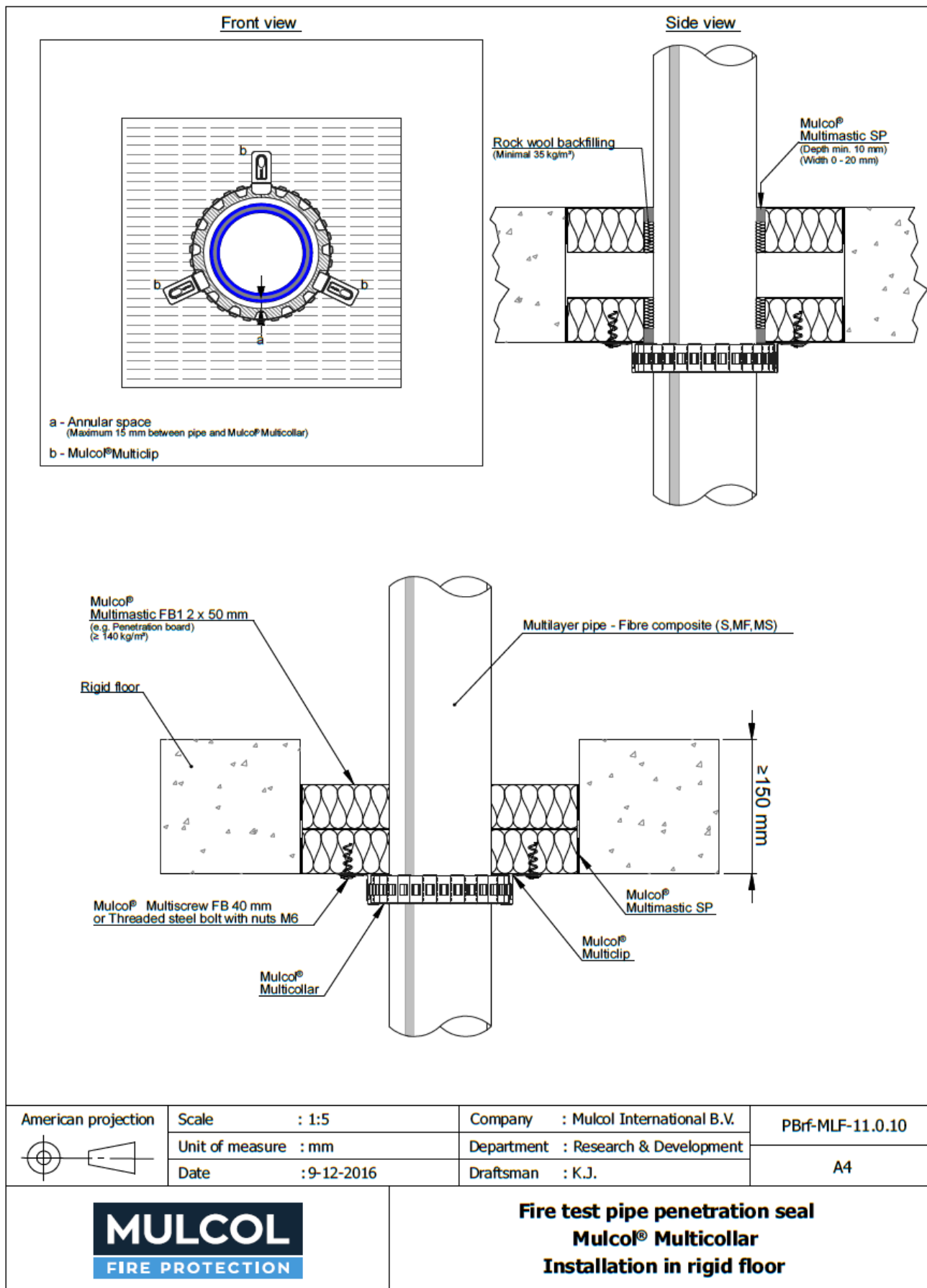

Pipe material	Maximum pipe diameter mm	Pipe wall thickness mm	No. of collars per face	Classification*
Aquatherm Blue-MF	50	6.9	one	EI 90 U/C
Aquatherm Green-MF	110	10.0	one	EI 120 U/C

* U/C pipe end configuration applies to C/C also

B.3.1.3 PP-R multilayer pipes insulated with AF/Armaflex made out of flexible elastomeric EPDM rubber foam with a min. reaction to fire class BL-s3, d0 or B-s3 or, d0 (to EN 13501-1), perpendicular to the floor, with one Mulcol® Multicollar Slim pipe collars to the soffit.

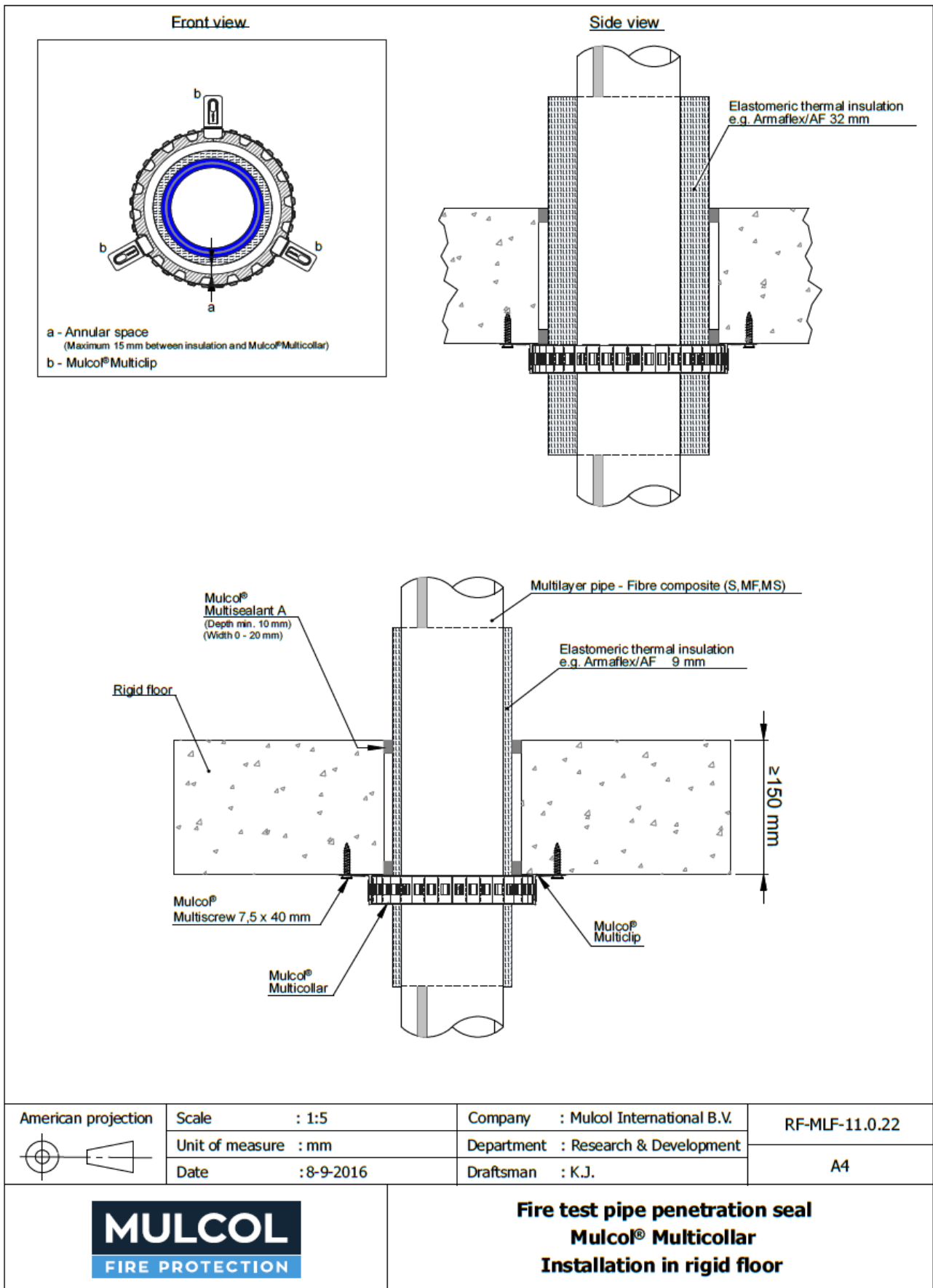

Pipe material [^]	Maximum pipe diameter mm	Pipe wall thickness mm	Insulation LS/CS/LI/CI thickness/ length mm	No. of collars per face	Classification*
Aquatherm Green-S	110	18.3	9-32 / 300 (min.)	One	EI 120 U/C
Aquatherm Green-MS		15.2			
Aquatherm Green-MF		15.1			
Aquatherm Blue-MF	20	2.8	9-32 / 300 (min.)		
	110	10.0			

* U/C pipe end configuration applies to C/C also

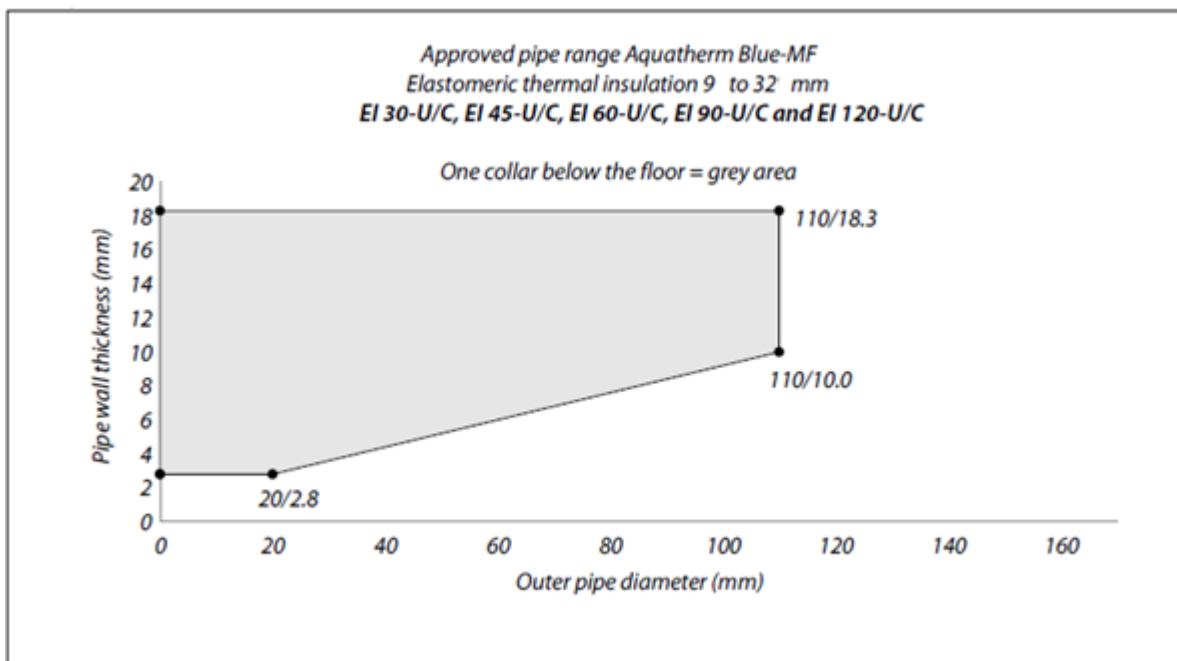

B.3.2 PP-R multilayer pipes with zero distance to the wall

B.3.2.1 PP-R multilayer pipes, perpendicular to the floor, in corner of floor, with one Mulcol® Multicollar Slim pipe collars to the soffit.

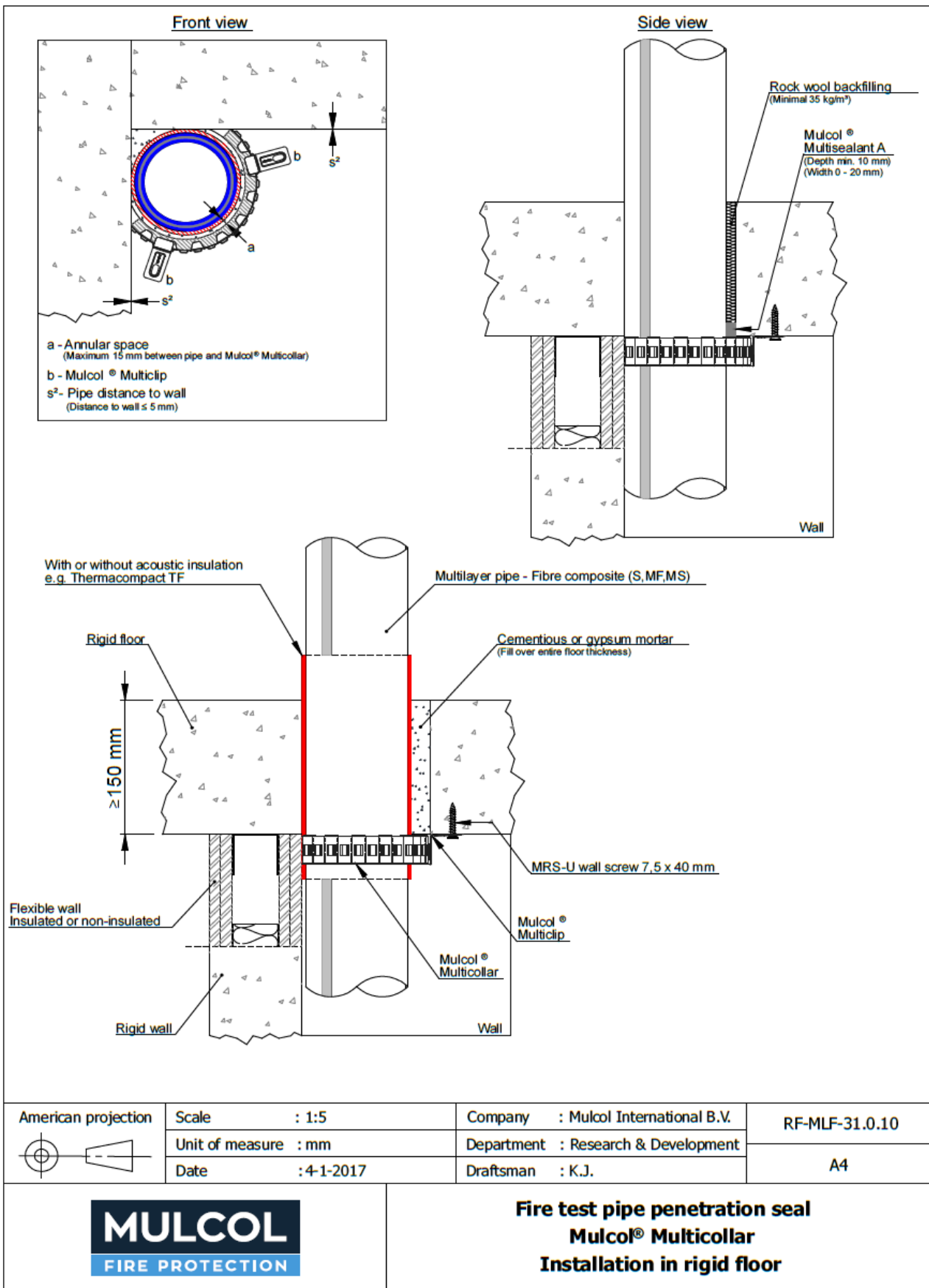

Pipe material	Maximum pipe diameter mm	Pipe wall thickness mm	No. of collars per face	Location	Classification*
Aquatherm Blue-MF	110	10.0	one	In corner	EI 90 U/C

* U/C pipe end configuration applies to C/C also

B.4 Aluminium composite pipes

B.4.1 Aluminium composite pipes in regular configurations

B.4.1.1 Aluminium composite pipes fitted perpendicular to the floor, with one Mulcol® Multicollar Slim pipe collars to the soffit.

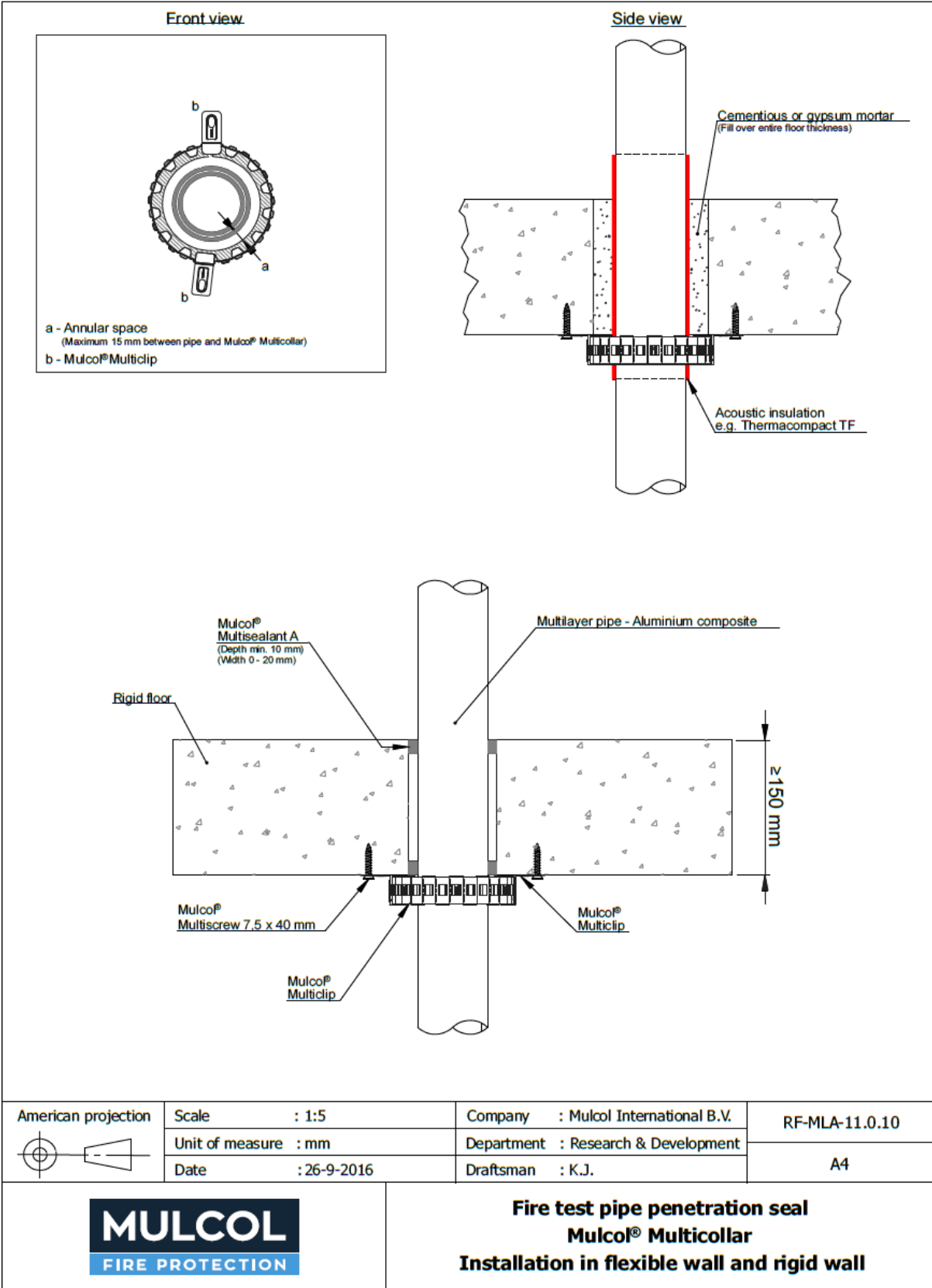

Pipe material [^]	Maximum pipe diameter mm	Pipe wall thickness mm	No. of collars per face	Classification*
Henco PE-Xc/AL/PE-Xc	20	2.0	one	EI 120 U/C
Uponor PE-Xa Aqua Pipe	25	3.5		
Henco PE-Xc/AL/PE-Xc	32	3.0		
	40	4.0		
Uponor PE-Xa Aqua Pipe	50	4.0		
Henco PE-Xc/AL/PE-Xc		63		4.5
		75		6.0
				E 120 U/C EI 60 U/C

* U/C pipe end configuration applies to C/C also

[^] Pipes may optionally be fitted with up to 4 mm thick sound decoupling insulation, min. 50 mm long (LS/CS/LI/CI)

B.4.1.2 Aluminium composite pipes fitted perpendicular to the floor, with two Mulcol® Multicollar Slim pipe collars to the soffit.

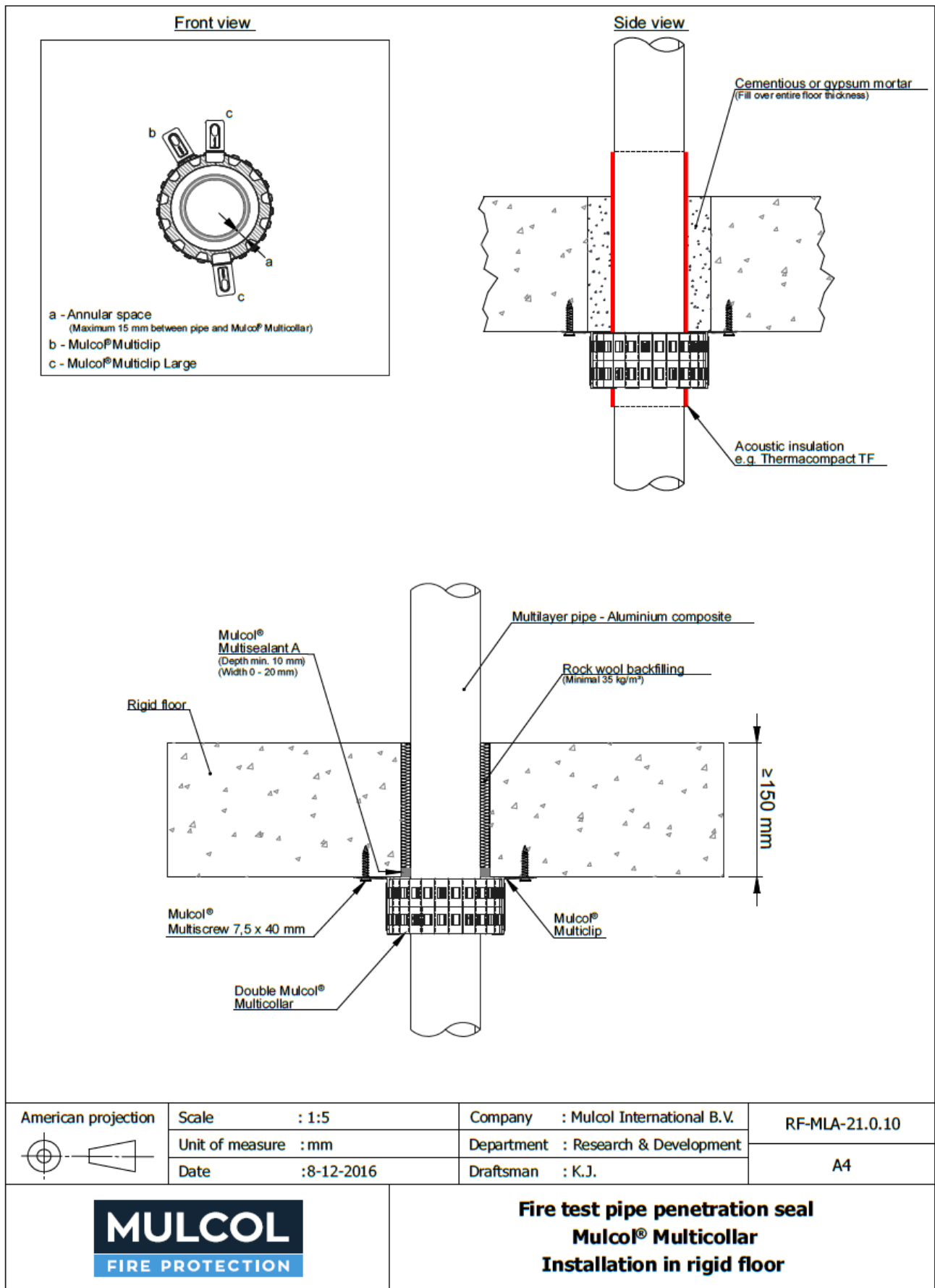

Pipe material [^]	Maximum pipe diameter mm	Pipe wall thickness mm	No. of collars per face	Classification*
Henco PE-Xc/AL/PE-Xc	63	4.5	two	EI 90 U/C
	75	6.0		

* U/C pipe end configuration applies to C/C also

[^] Pipes may optionally be fitted with up to 4 mm thick sound decoupling insulation, min. 50 mm long (LS/CS/LI/CI)

B.4.1.3 Aluminium composite pipes insulated with PE-foam with a min. reaction to fire class CL-s1-d0 (to EN 13501-1), perpendicular to the floor, with one Mulcol® Multicollar Slim pipe collars to the soffit

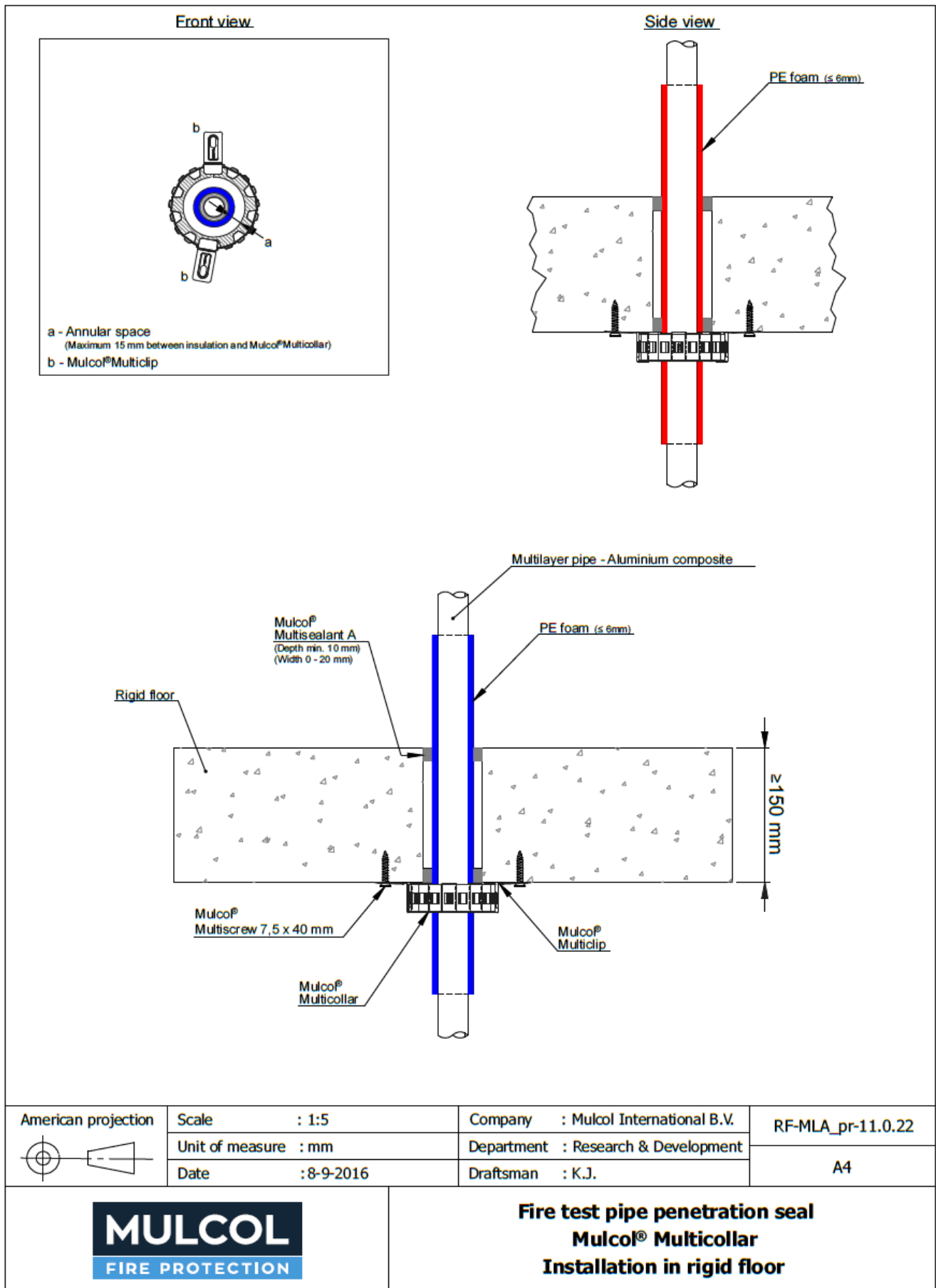

Pipe material^	Maximum pipe diameter mm	Pipe wall thickness mm	Insulation LS/CS/LI/CI thickness/length mm	No. of collars per face	Classification*
Henco PE-Xc/AL/PE-Xc	32	3.0	6 / 300 (min.)	One	EI 120 U/C

* U/C pipe end configuration applies to C/C also

B.4.1.4 Aluminium composite pipes insulated with AF/Armaflex made out of flexible elastomeric EPDM rubber foam with a min. reaction to fire class BL-s3, d0 or B-s3, d0 (to EN 13501-1), perpendicular to the floor, with one Mulcol® Multicollar Slim pipe collars to the soffit

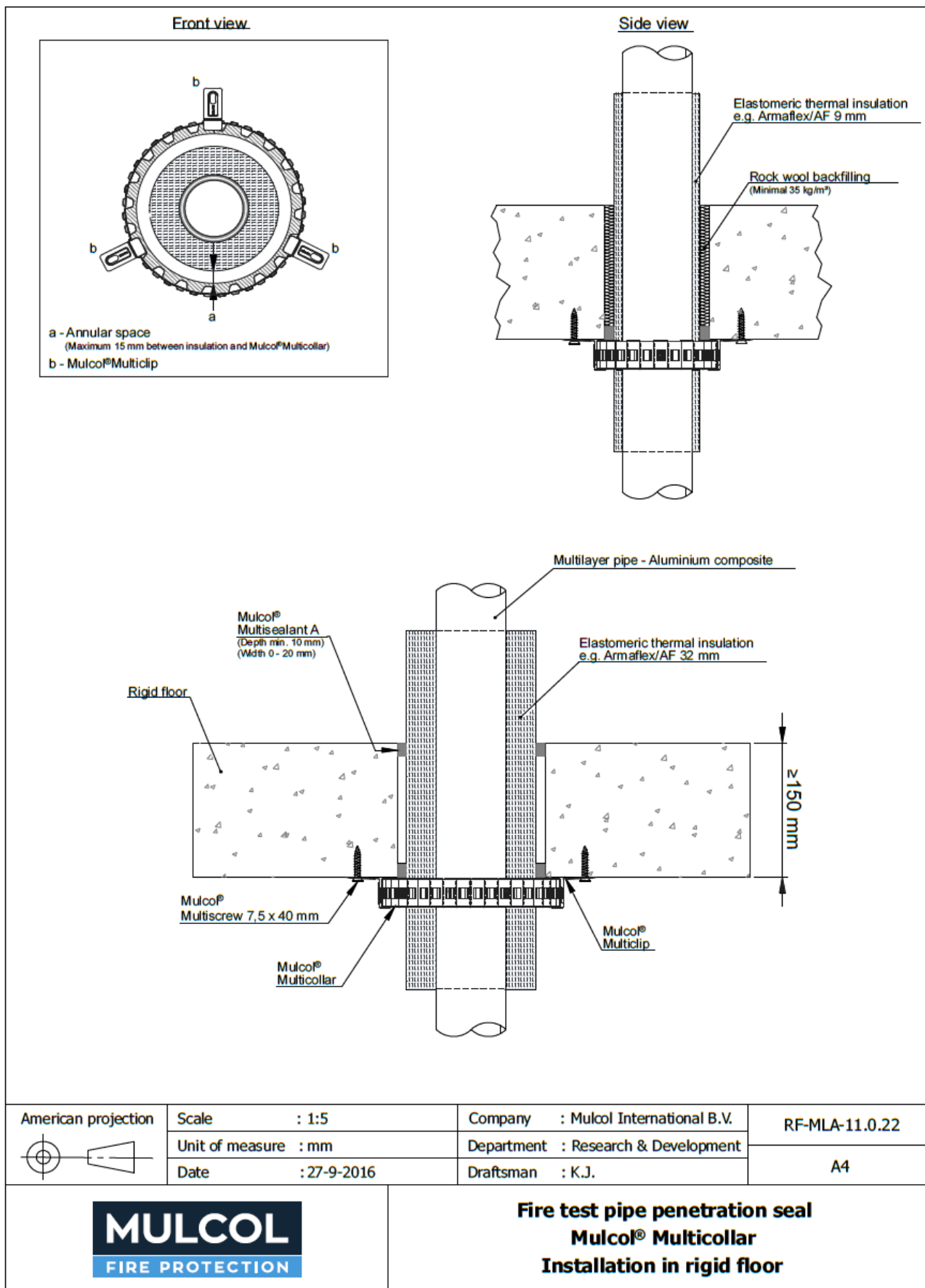

Pipe material [^]	Maximum pipe diameter mm	Pipe wall thickness mm	Insulation LS/CS/LI/CI thickness/ length mm	No. of collars per face	Classification*
Henco PE-Xc/AL/PE-Xc	20	2.0	9-32 / 500 (min.)	One	EI 120 U/C
Uponor PE-Xa Aqua Pipe	25	3.5			
Henco PE-Xc/AL/PE-Xc	32	3.0			
	40	3.5			
Uponor PE-Xa Aqua Pipe	40	4.0			
Henco PE-Xc/AL/PE-Xc	50	4.0			
Alpex Duo PE-Xb/AL/PE-Xb	63	4.5			
Henco PE-Xc/AL/PE-Xc	75	6.0			
	90	7.0			
	90	7.0			
Uponor PE-Xa Aqua Pipe	110	10.0	9-32 / 500 (min.)		EI 90 U/C

* U/C pipe end configuration applies to C/C also

B.4.1.5 Aluminium composite pipes in PE conduit, perpendicular to the floor, with one Mulcol® Multicollar Slim pipe collars to the soffit

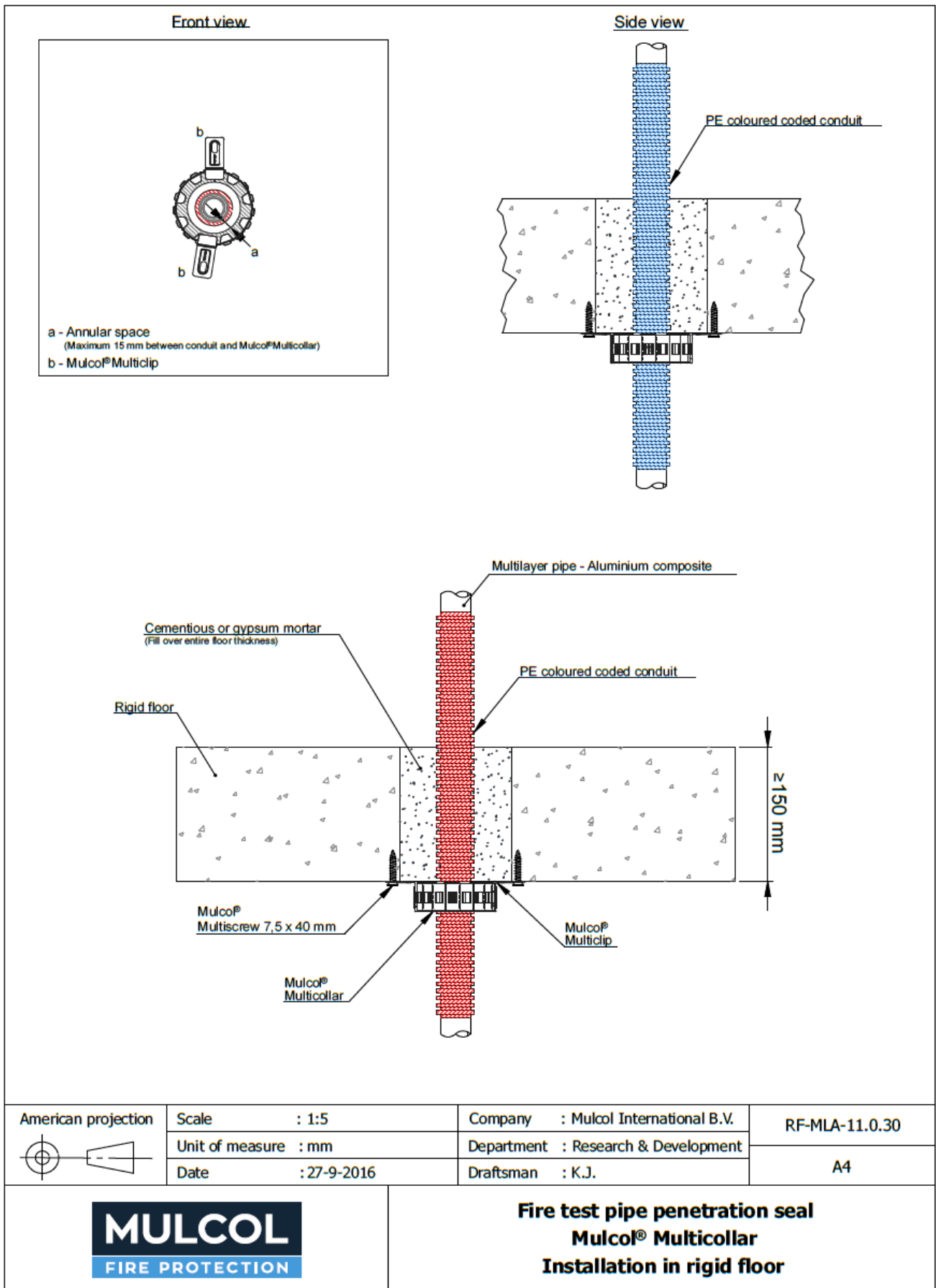

Pipe material [^]	Maximum pipe diameter mm	Pipe wall thickness mm	Conduit diameter / length LS/CS mm	No. of collars per face	Classification*
Henco PE-Xc/AL/PE-Xc pipes with PE conduit insulation	32	3.0	40 / 50 (min.)	One	EI 120 U/C

* U/C pipe end configuration applies to C/C also

B.4.1.6 Up to 4 x Aluminium composite pipes insulated with PE-foam with a min. reaction to fire class CL-s1-d0 (to EN 13501-1), perpendicular to the floor, with two Mulcol® Multicollar Slim pipe collars to the soffit.

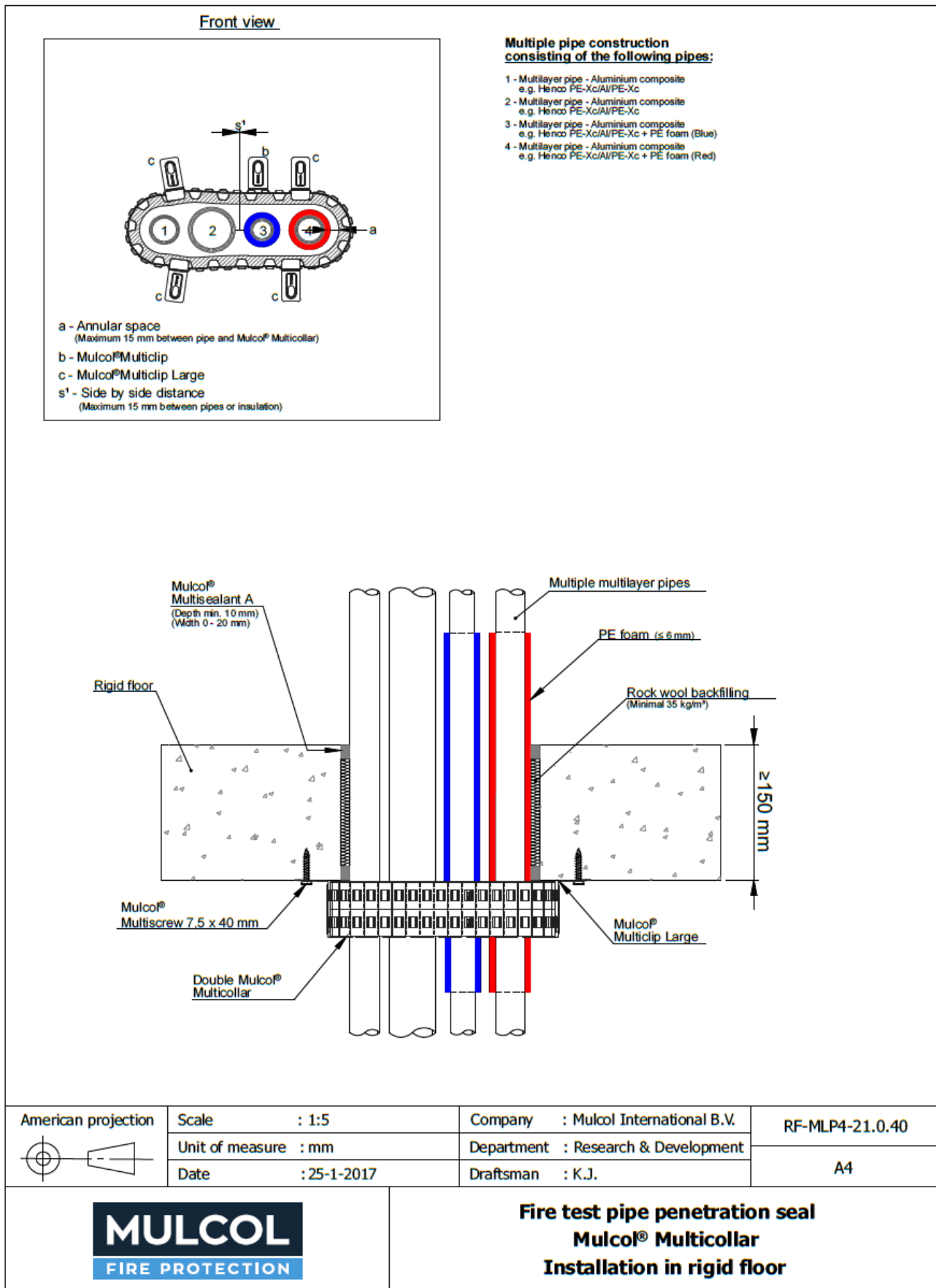

Pipe material [^]	Maximum pipe diameter mm	Pipe wall thickness mm	Insulation LS/CS/LI/CI thickness/ length mm	No. of collars per face	Classification*
Henco PE-Xc/AL/PE-Xc	32	3.0	None	Two	EI 120 U/C
	50	4.0			E 120 U/C EI 90 U/C
	26	3.0	6 / 300 (min.)		EI 120 U/C
	32	3.0			

* U/C pipe end configuration applies to C/C also

B.5 Multiple services in a double collar

B.5.1 Mixed pipes and cables in regular configurations

B.5.1.1 Up to 3 x mixed pipes and cables, perpendicular to the wall, with two Mulcol® Multicollar Slim pipe collars to the soffit.

Front view

a - Annular space
(Maximum 15 mm between pipe and Mulco® Multicollar)

b - Mulco® Multiclip

c - Mulco® Multiclip Large

s¹ - Side by side distance
(Maximum 15 mm between pipes)

Multiple pipe construction consisting of the following pipes:

- 1 - Multilayer pipe - Fibre composite
e.g. Aquatherm green pipe PP-R/GF7/EMF
- 2 - Multilayer pipe - Aluminium composite
e.g. Henco PE-Xc/AMPE-Xc
- 3 - Plastic pipe
e.g. Agru PE-HD
- 4 - Electric cables
e.g. UTP Cable Cat. 5, UTP Cable Cat. 6, YMKV 3 x 2,5 mm,
YMKV Cable 5 x 1,5 mm or YMKV Cable 5 x 2,5 mm

Mulco® Multisealant A
(Depth min. 10 mm)
(Width 0 - 20 mm)

Rigid floor

Mulco® Multiscrew 7,5 x 40 mm

Double Mulco® Multicollar

Mulco® Multiclip Large

Multiple pipes with electric cables

≥ 150 mm

	Scale : 1:5	Company : Mulcol International B.V.	RF-MLP3-21.0.10
	Unit of measure : mm	Department : Research & Development	
	Date : 18-1-2017	Draftsman : K.J.	A4

Fire test pipe penetration seal
Mulcol® Multicollar
Installation in rigid floor

Pipe material / cable	Maximum pipe diameter mm	Pipe wall thickness mm	No. of collars per face	Classification*
PE-HD / PE / ABS / SAN+PVC	90	2.8	Two	EI 120 U/U
Henco PE-Xc/AL/PE-Xc	50	4.0		EI 120 U/C
Aquatherm Green-MF		6.9		
Telecom UTP Cat. 5 or Cat. 6	1 no.	NA		
Sheathed cable YMKV 3 x 2.5 mm ² , YMKV 5 x 1.5 mm ² or YMKV 5 x 2.5 mm ²	1 No.	NA		EI 120

* U/U pipe end configuration applies to U/C, C/U and C/C also

B.5.1.2 Up to 3 x mixed pipes and cables, insulated with PE-foam with a min. reaction to fire class CL-s1-d0 (to EN 13501-1), perpendicular to the floor, with two Mulcol® Multicollar Slim pipe collars to the soffit.

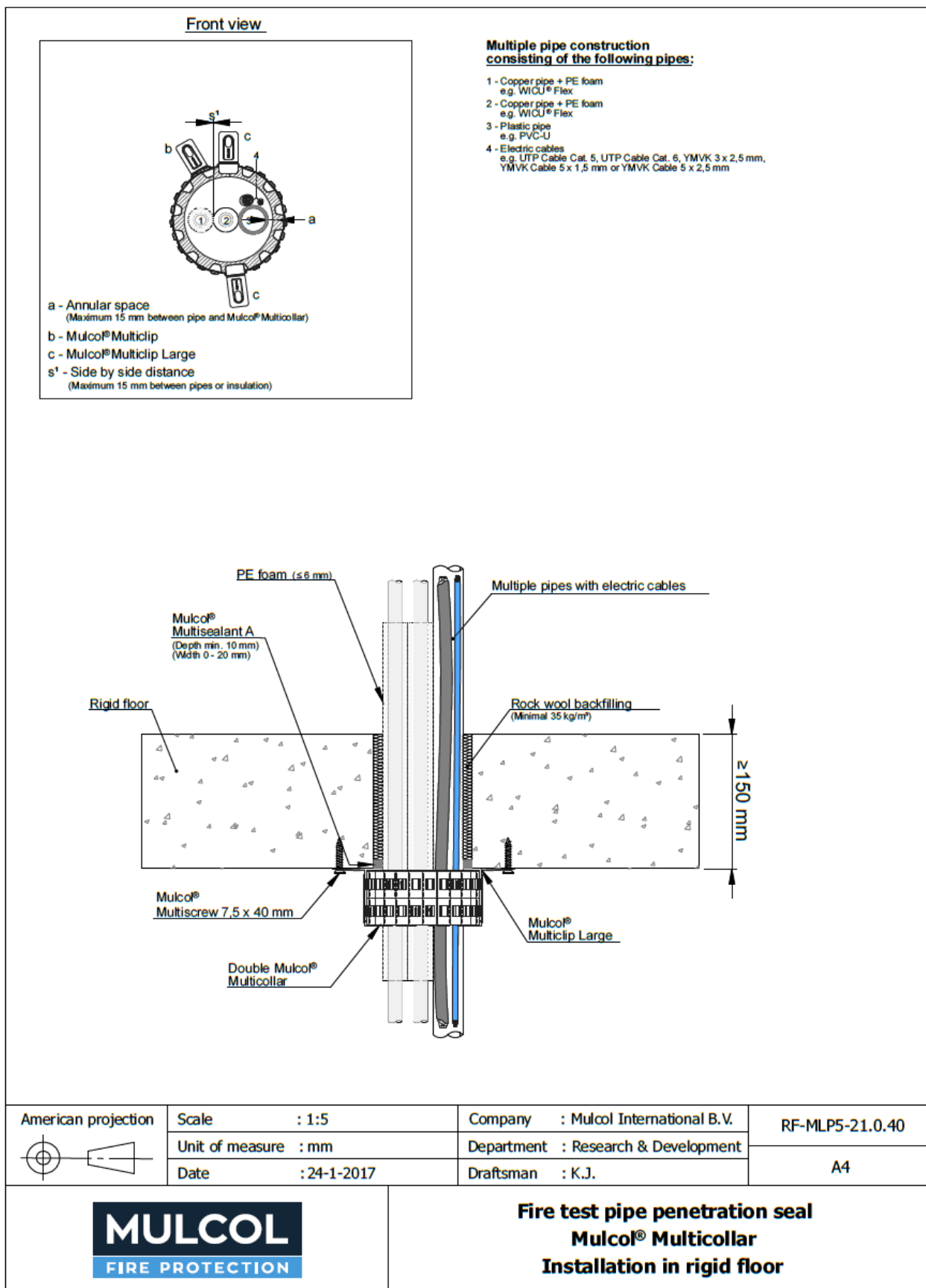

Pipe material	Maximum pipe diameter mm	Pipe wall thickness mm	Insulation LS/CS/LI/CI thickness/length mm	No. of collars per face	Classification*
Copper with Wicu-flex PE foam insulation	15	1.5	6 / 300 (min.)	Two	EI 120 C/U
PVC-U / PVC-C	32	3.0	None		EI 120 U/U
Telecom UTP Cat. 5 or Cat. 6	1 No.	NA			EI 120
Sheathed cable YMVK 3 x 2.5 mm ² , YMVK 5 x 1.5 mm ² or YMVK 5 x 2.5 mm ²	1 No.	NA			EI 120

* U/U pipe end configuration applies to U/C, C/U and C/C also

B.5.1.3 Up to 4 x Aluminium composite pipes insulated with PE-foam with a min. reaction to fire class CL-s1-d0 (to EN 13501-1), perpendicular to the floor, with two Mulcol® Multicollar Slim pipe collars to the soffit.

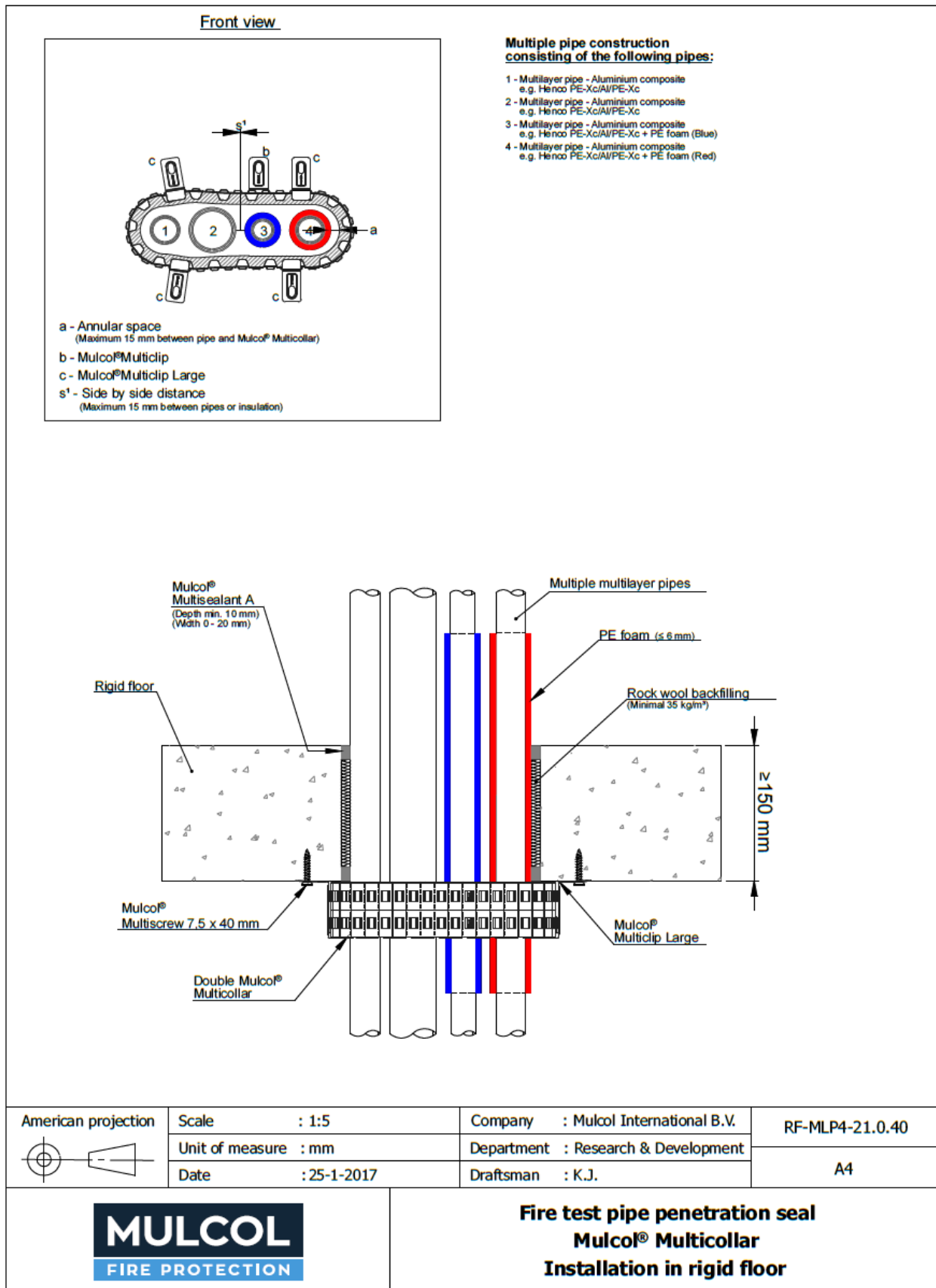

Pipe material [^]	Maximum pipe diameter mm	Pipe wall thickness mm	Insulation LS/CS/LI/CI thickness/ length mm	No. of collars per face	Classification*
Henco PE-Xc/AL/PE-Xc	32	3.0	None	Two	EI 120 U/C
	50	4.0			E 120 U/C EI 90 U/C
	26	3.0	6 / 300 (min.)		EI 120 U/C
	32	3.0			

* U/C pipe end configuration applies to C/C also

B.6 Electrical cables

B.6.1 Electrical cables in regular configurations

B.6.1.1 Electrical cables, fitted perpendicular to the floor, with one Mulcol® Multicollar Slim pipe collars to the soffit

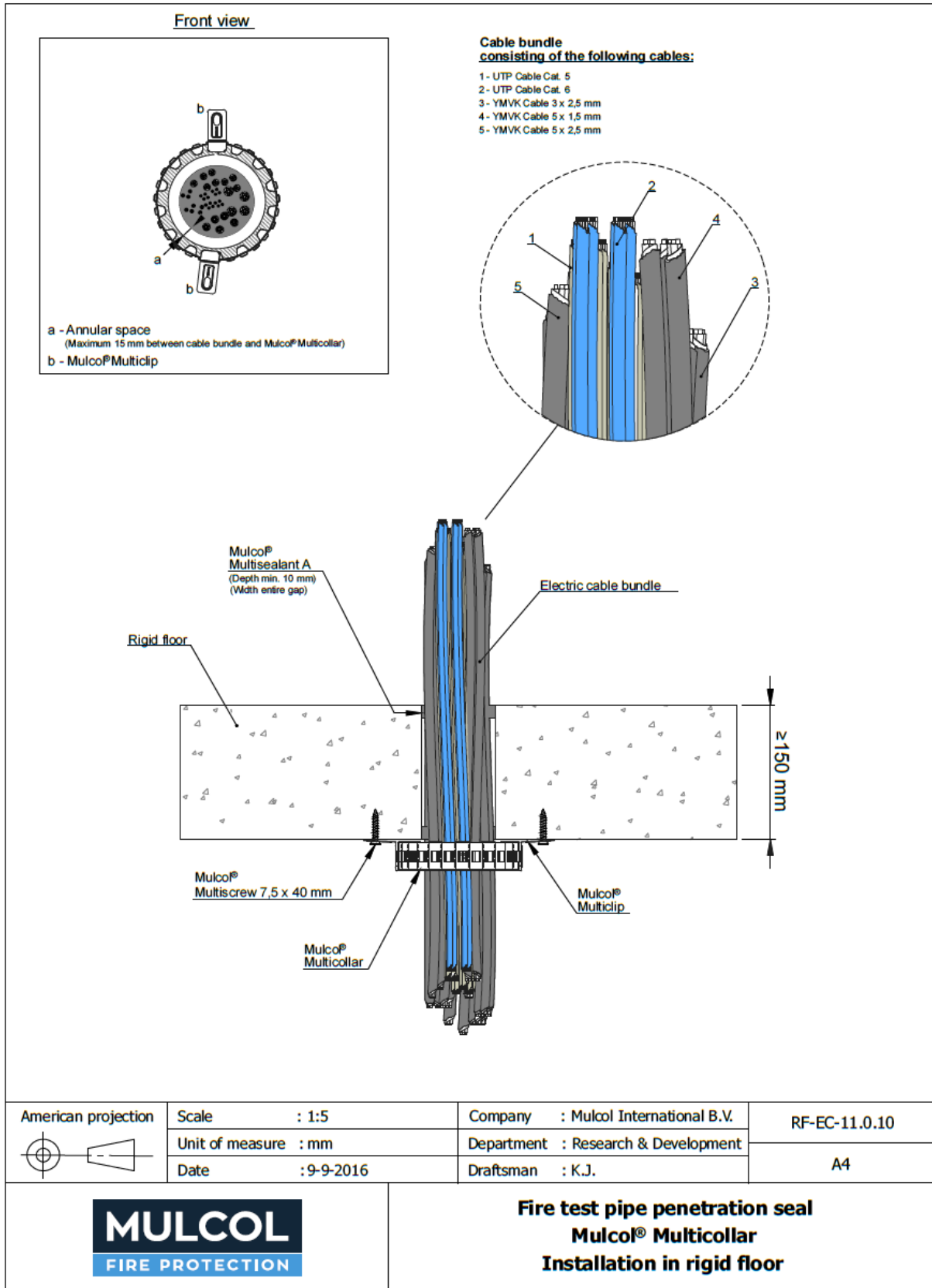

Max. number	Maximum aperture diameter mm	Permitted cables (empty to full fill)	No. of collars per face	Classification*
42	80	Telecommunication cables UTP Cat. 5	One	EI 120
		Telecommunication cables UTP Cat. 6		
		Sheathed cable YMKV 3 x 2.5 mm ²		
		Sheathed cable YMKV 5 x 1.5 mm ²		
		Sheathed cable YMKV 5 x 2.5 mm ²		

B.6.1.2 PE conduits containing electrical cables, fitted perpendicular to the floor, with one Mulcol® Multicollar Slim pipe collars to the soffit

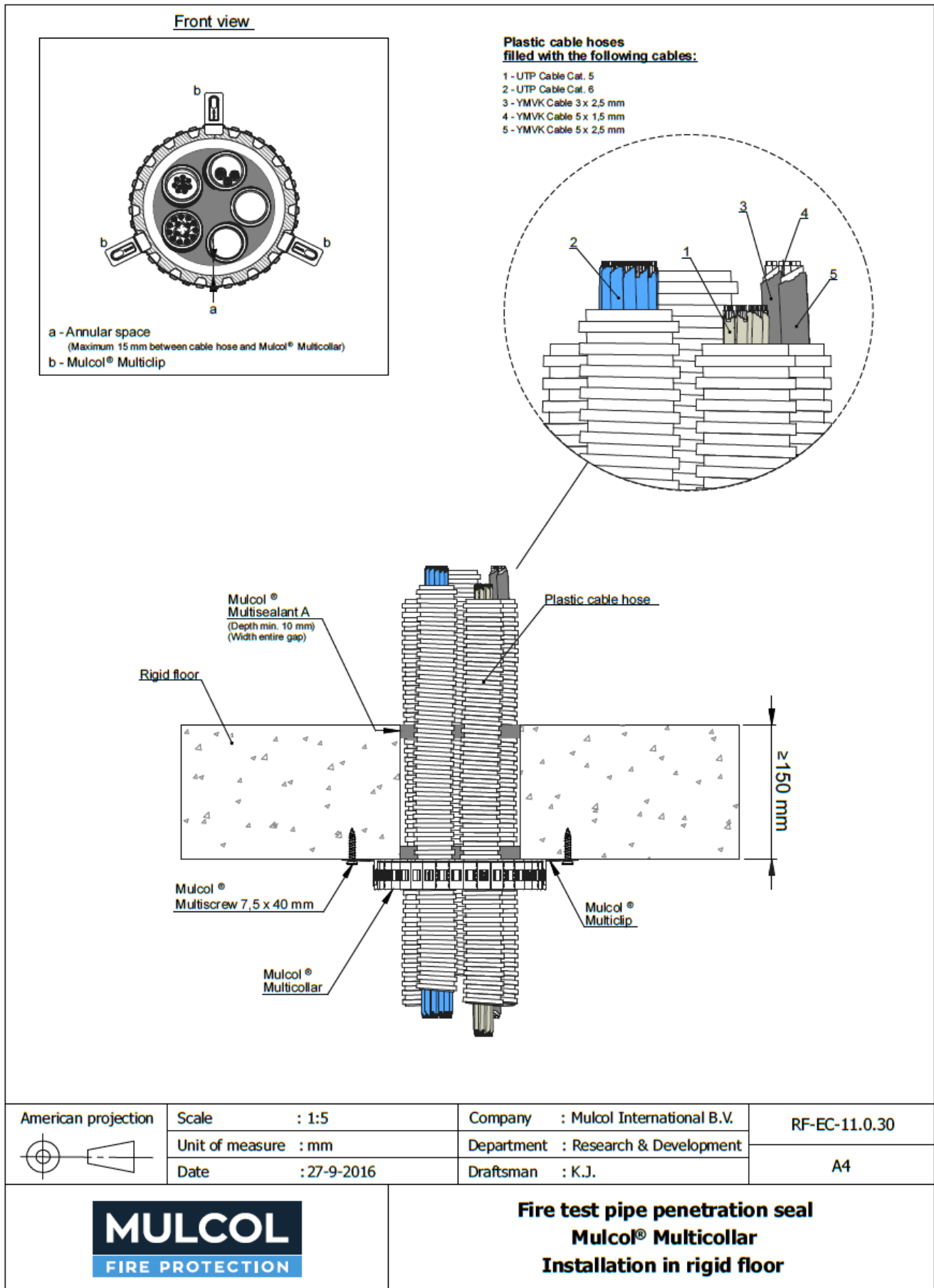

Pipe material / max. number	Maximum pipe diameter mm	Maximum aperture diameter mm	Permitted cables (empty to full fill)	No. of collars per face	Classification*
PE / 5	50	130	Telecommunication cables UTP Cat. 5	One	EI 60 U/U
			Telecommunication cables UTP Cat. 6		
			Sheathed cable YMVK 3 x 2.5 mm ²		
			Sheathed cable YMVK 5 x 1.5 mm ²		
			Sheathed cable YMVK 5 x 2.5 mm ²		

* U/U pipe end configuration applies to U/C, C/U and C/C also

B.6.1.3 PVC pipes containing electrical cables, fitted perpendicular to the floor, with one Mulcol® Multicollar Slim pipe collars to the soffit

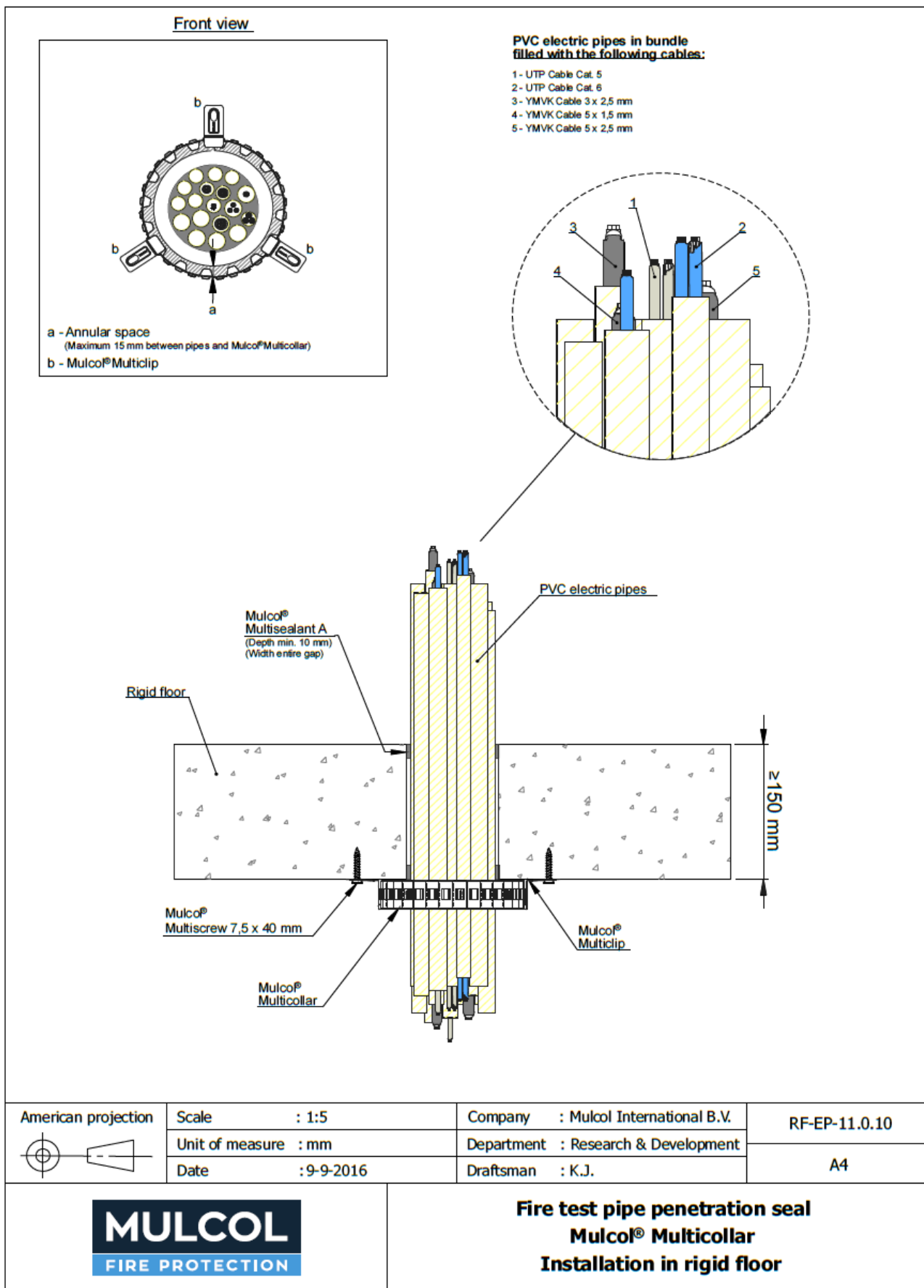

C:\1744\15\PA_011_116

Pipe material / max. number	Maximum pipe diameter mm	Maximum aperture diameter mm	Permitted cables (empty to full fill)	No. of collars per face	Classification*
PVC / 18	25	100	Telecommunication cables UTP Cat. 5	One	EI 120 U/U
			Telecommunication cables UTP Cat. 6		
			Sheathed cable YMVK 3 x 2.5 mm ²		
			Sheathed cable YMVK 5 x 1.5 mm ²		
			Sheathed cable YMVK 5 x 2.5 mm ²		

* U/U pipe end configuration applies to U/C, C/U and C/C also

B.7 Flue Gas Pipes

B.7.1 Flue Gas Pipes in regular configurations

B.7.1.1 Aluminium flue gas pipes fitted perpendicular to the floor, with two Mulcol® Multicollar Slim pipe collars to the soffit.

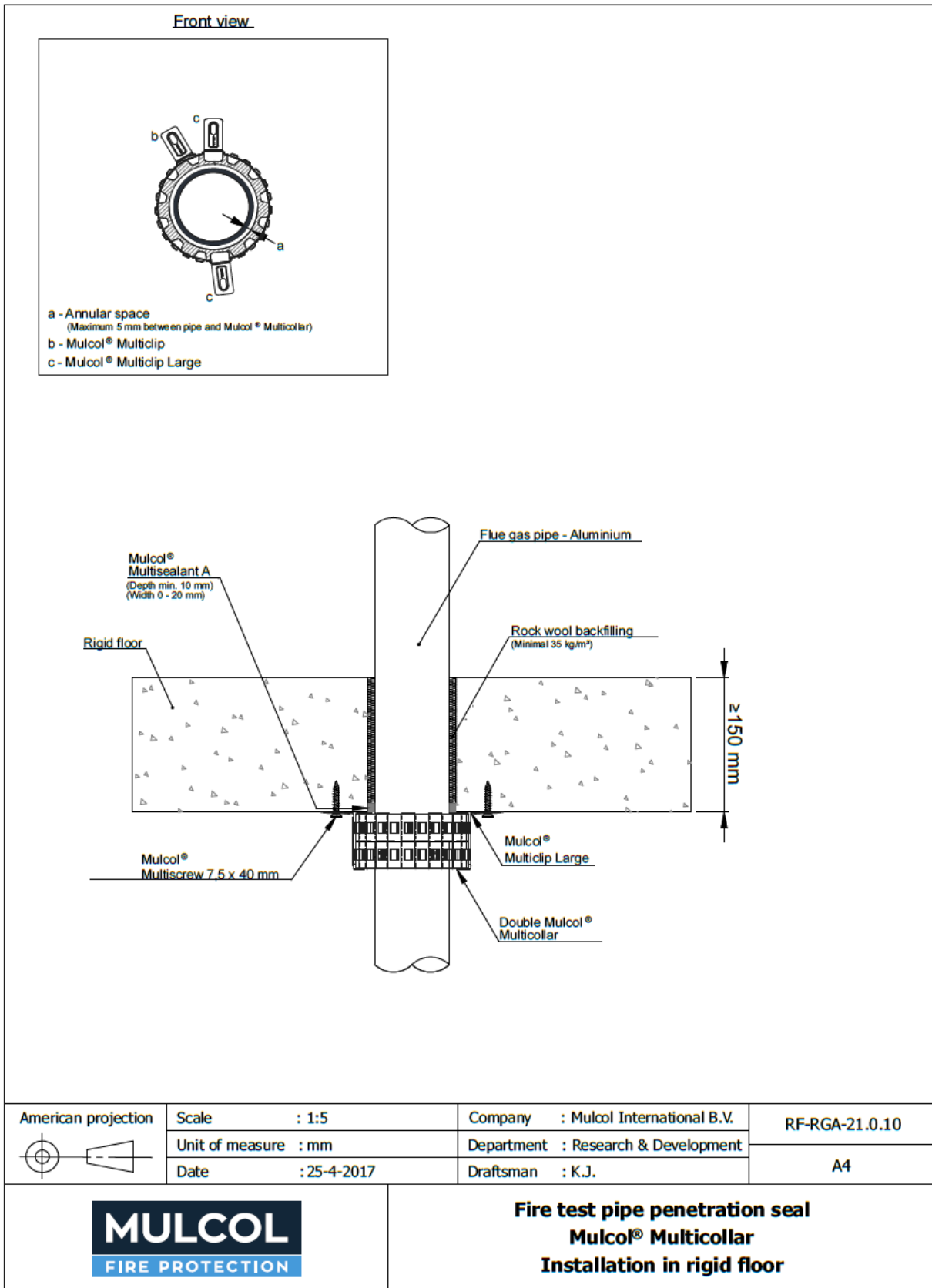

Pipe material	Maximum pipe diameter mm	Pipe wall thickness mm	No. of collars per face	Classification*
Aluminium	100	1.5	two	E 90 U/C EI 15 U/C
	130			E 90 U/C

* U/C pipe end configuration applies to C/U and C/C also

B.7.1.2 Concentric steel flue gas pipes fitted perpendicular to the floor, with two Mulcol® Multicollar Slim pipe collars to the soffit.

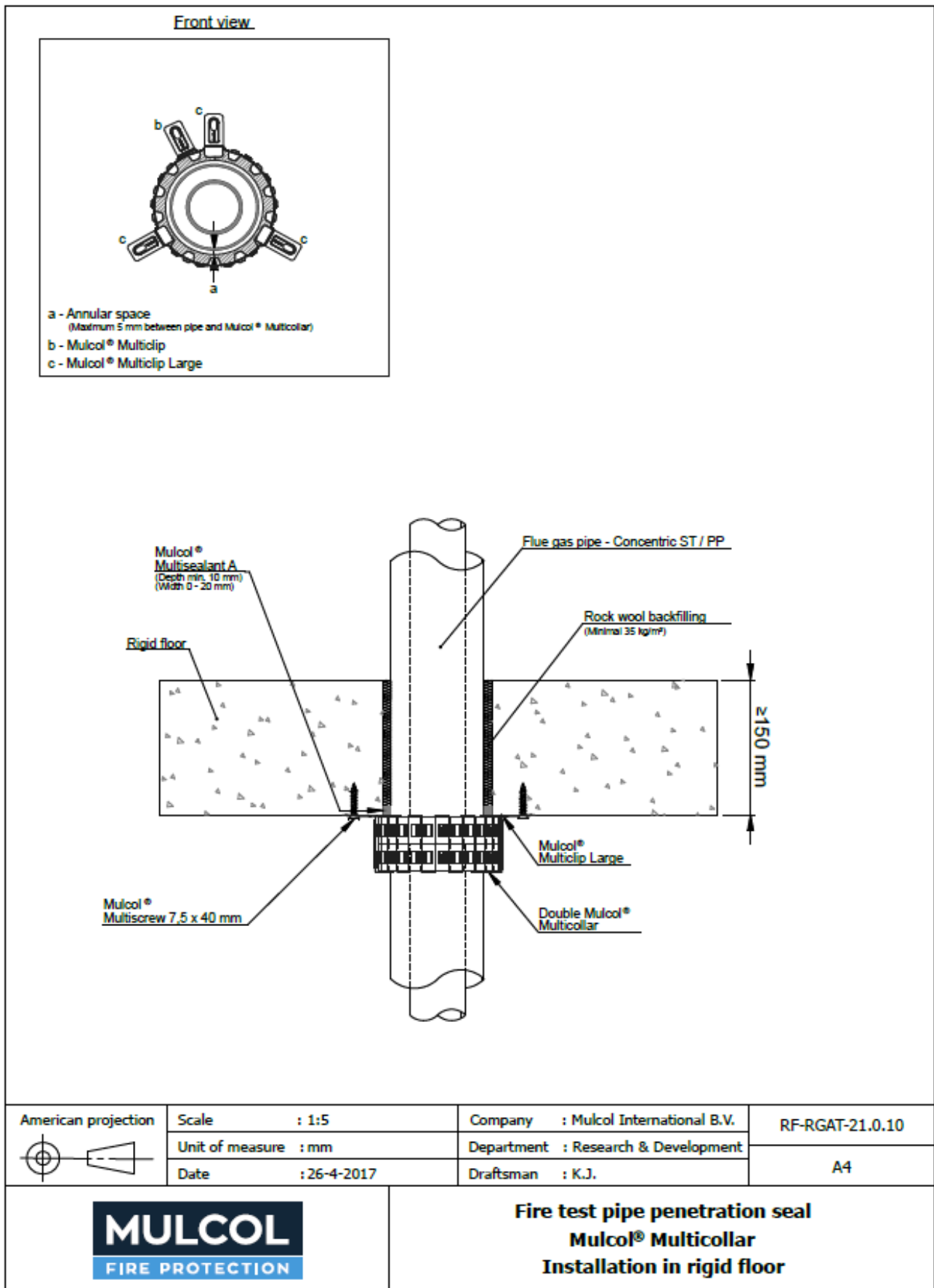

Pipe material	Outer Steel pipe diameter mm	Inner PP pipe diameter mm	No. of collars per face	Classification*
Steel/PP flue gas system Concentric	100	60	two	E 90 U/C
	125	80		
	150	100		
	200	130		

* U/C pipe end configuration applies to C/U and C/C also

B.7.1.3 Plastic flue gas pipes fitted perpendicular to the floor, with one Mulcol® Multicollar Slim pipe collars to the soffit

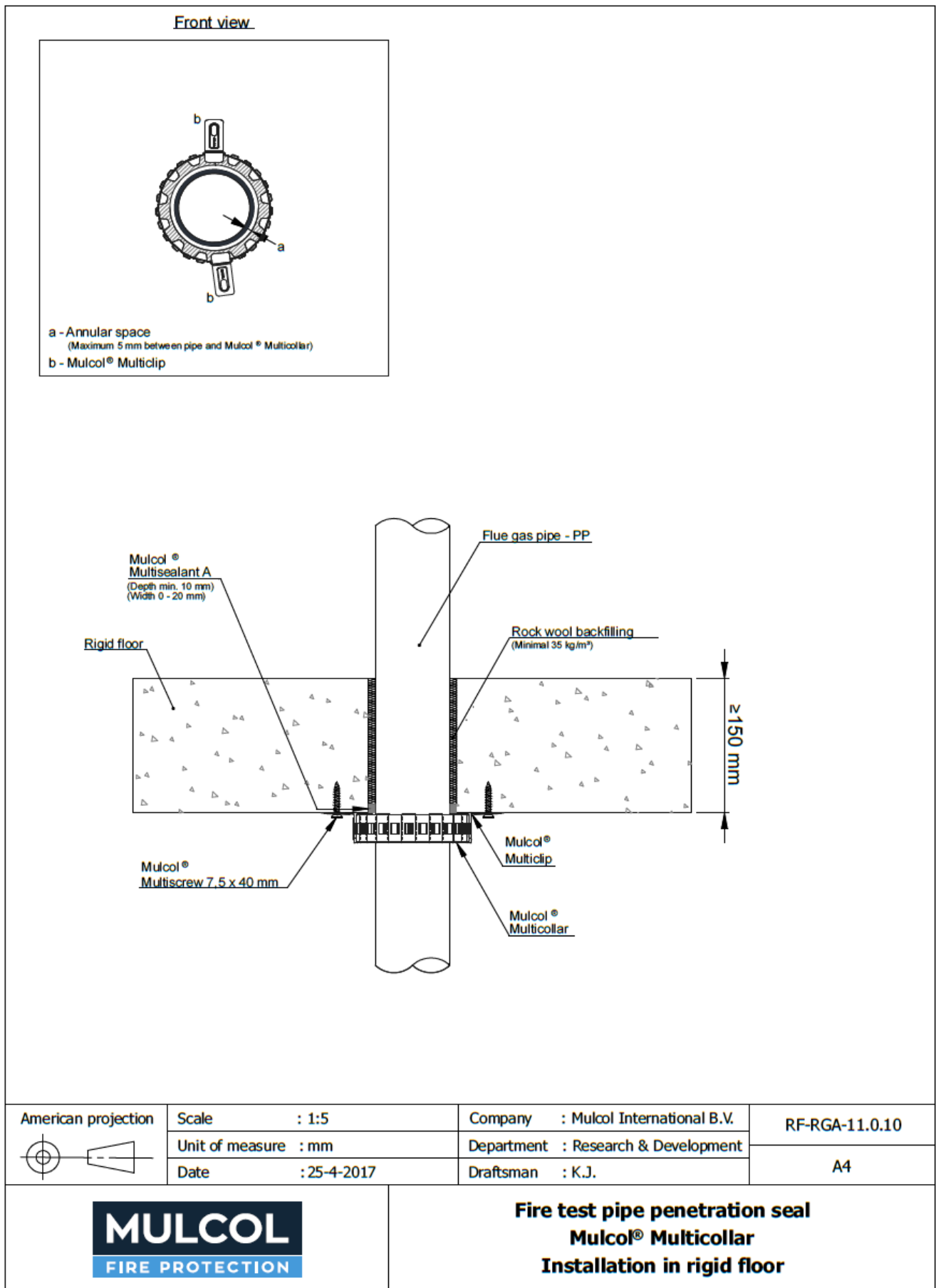

Pipe material	Maximum Pipe diameter mm	Pipe wall thickness mm	No. of collars per face	Classification*
PP	40	1.8-4.0	one	EI 90 U/U
	125	3.1-4.0		

* U/U pipe end configuration applies to U/C, C/U and C/C also

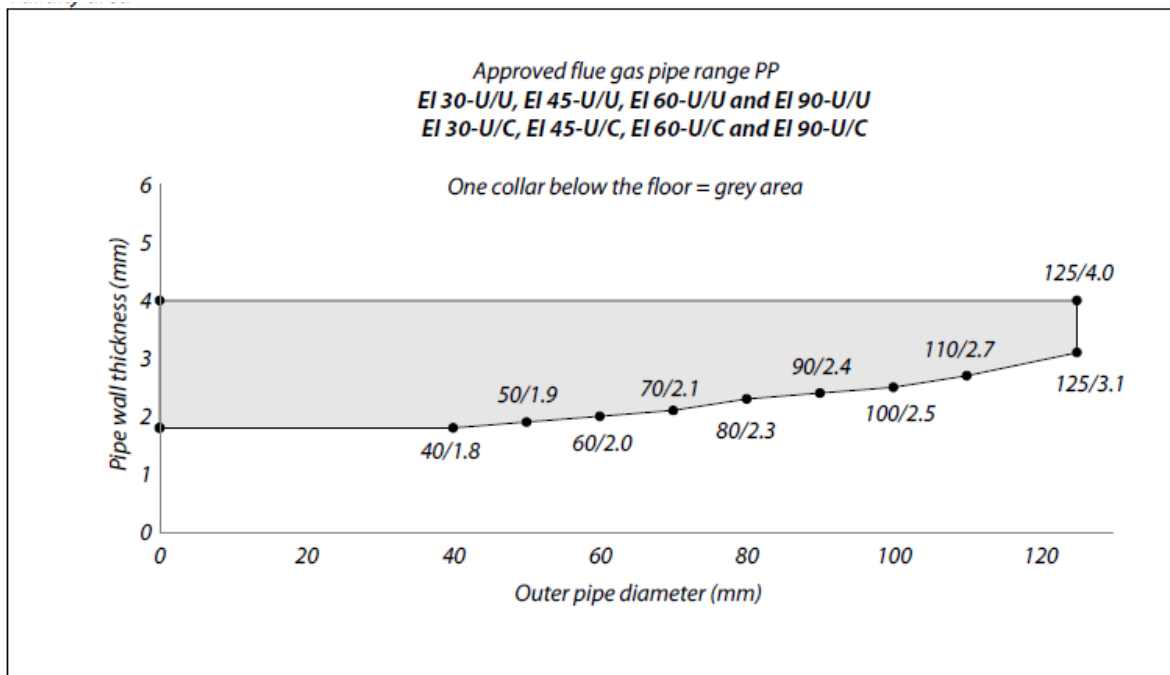

B.7.1.4 Concentric plastic flue gas pipes fitted perpendicular to the floor, with one Mulcol® Multicollar Slim pipe collars to the soffit

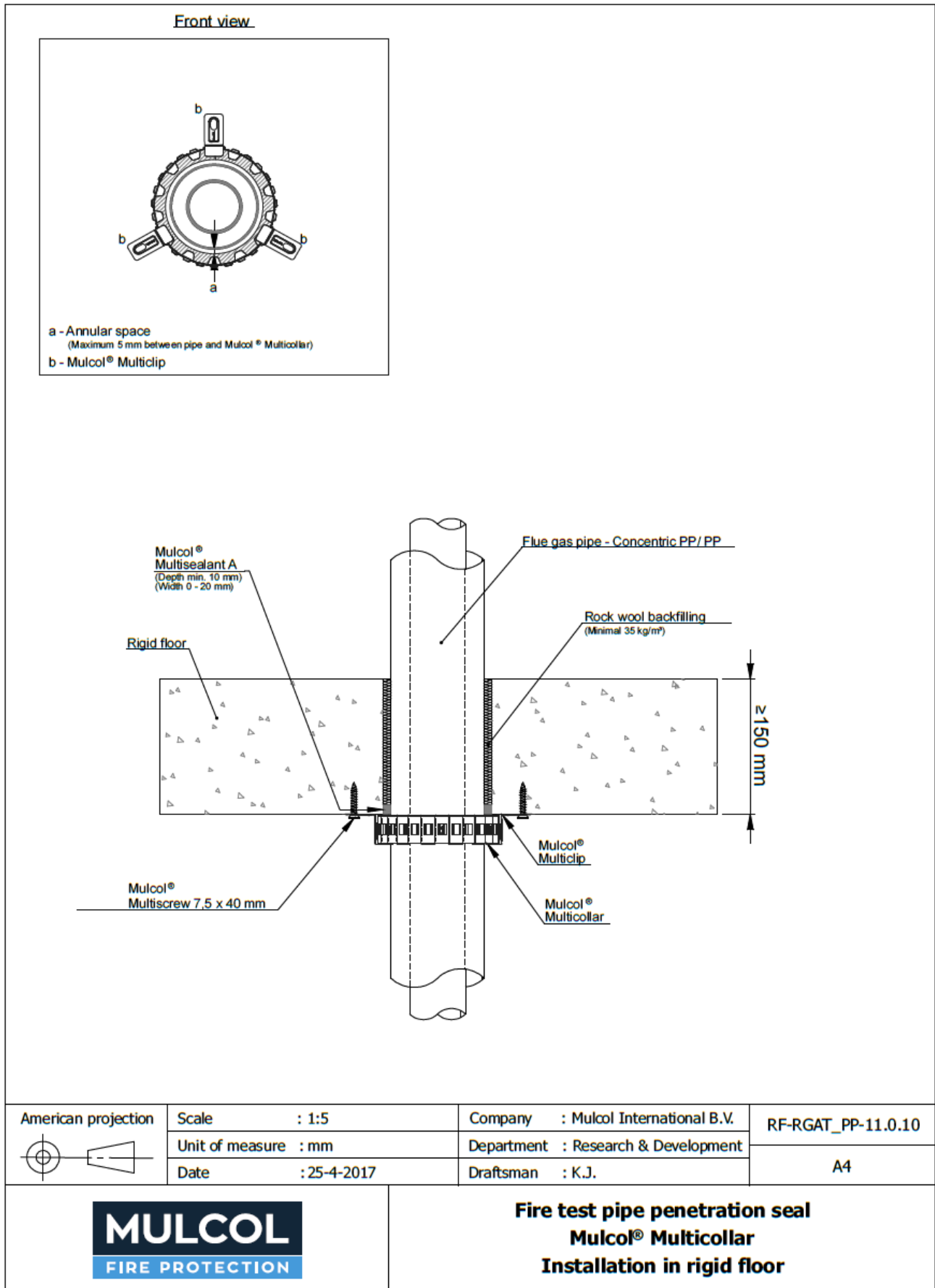

Pipe material	Maximum Pipe diameter mm	Pipe wall thickness mm	No. of collars per face	Classification*
PP/PP Concentric	40	1.8-4.0	one	EI 90 U/U
	125	3.1-4.0		

* U/U pipe end configuration applies to U/C, C/U and C/C also

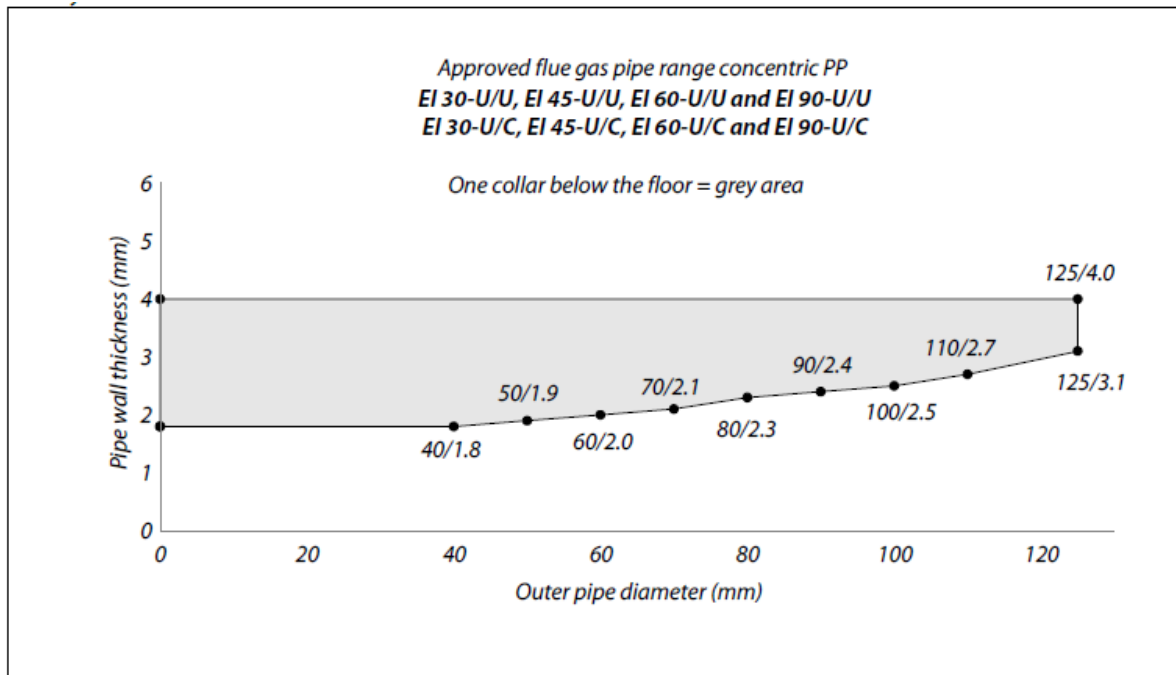

B.8 Metal pipes

B.8.1 Metal pipes in regular configurations

B.8.1.1 Metal pipes fitted perpendicular to the floor, with one Mulcol® Multicollar Slim pipe collars to the soffit

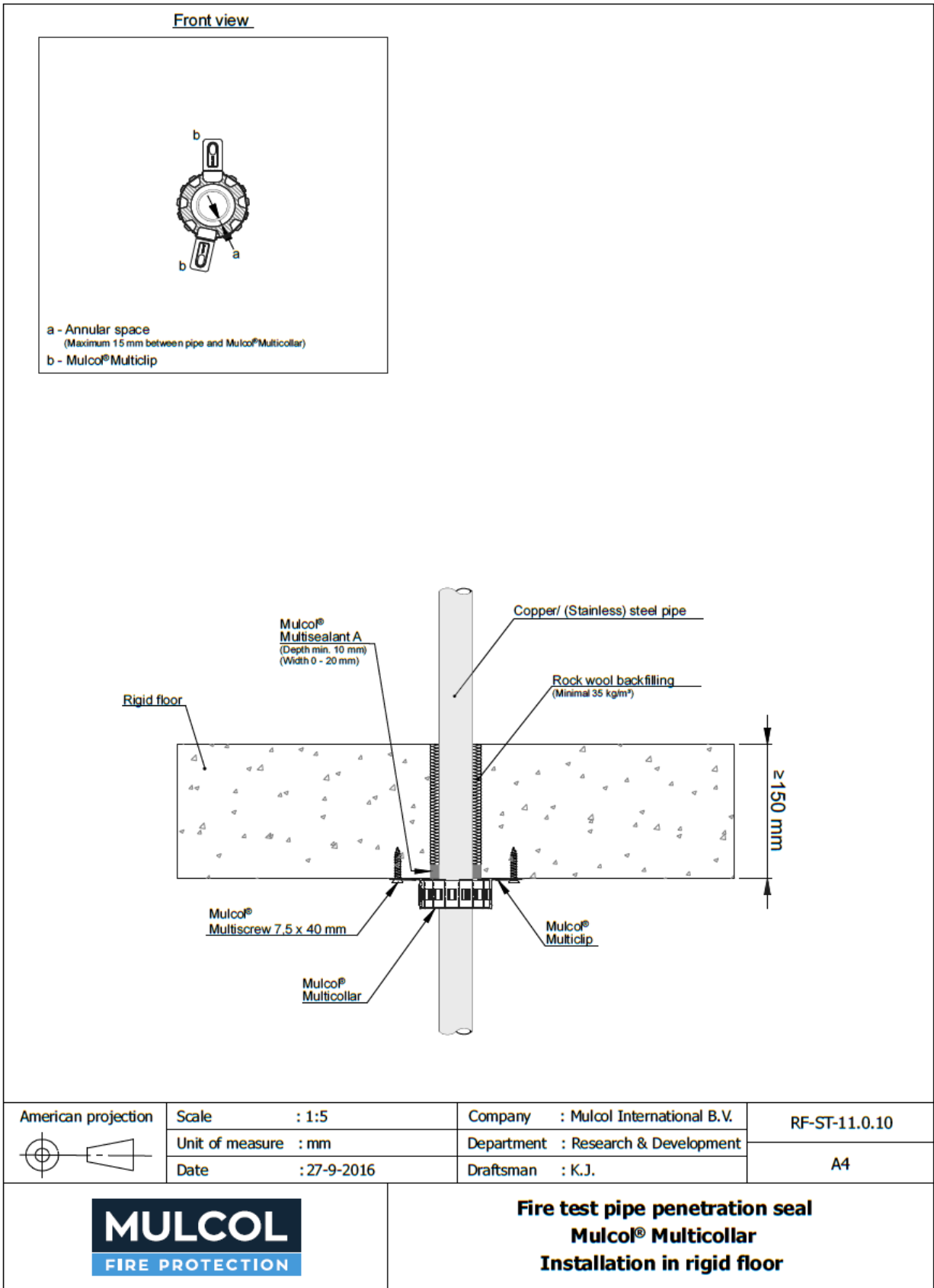

Pipe material	Maximum Pipe diameter mm	Pipe wall thickness mm	No. of collars per face	Classification*
Copper / Steel / Iron / Stainless steel	35	1.5-14.2	One	E 120 C/U EI 20 C/U

* C/U pipe end configuration applies to C/C also

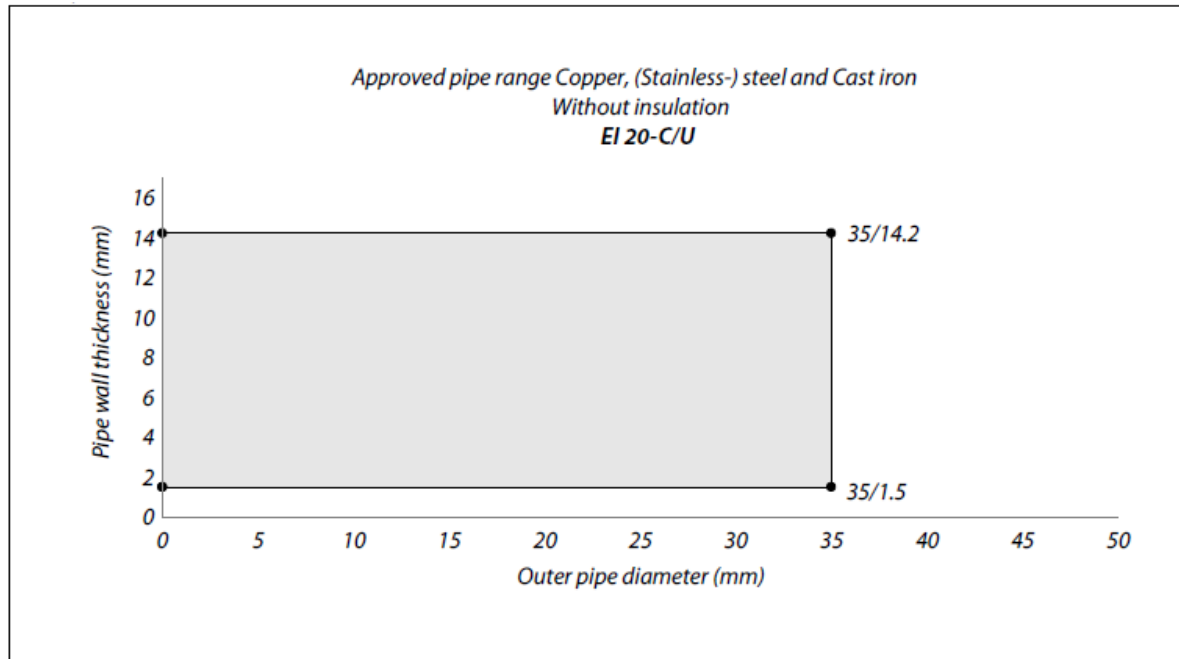

B.8.1.2 Metal pipes insulated with AF/Armaflex made out of flexible elastomeric EPDM rubber foam with min. reaction to fire class BL-s3, d0 or B-s3, d0 (EN 13501-1), fitted perpendicular to the floor, with one Mulcol® Multicollar Slim pipe collars to the soffit.

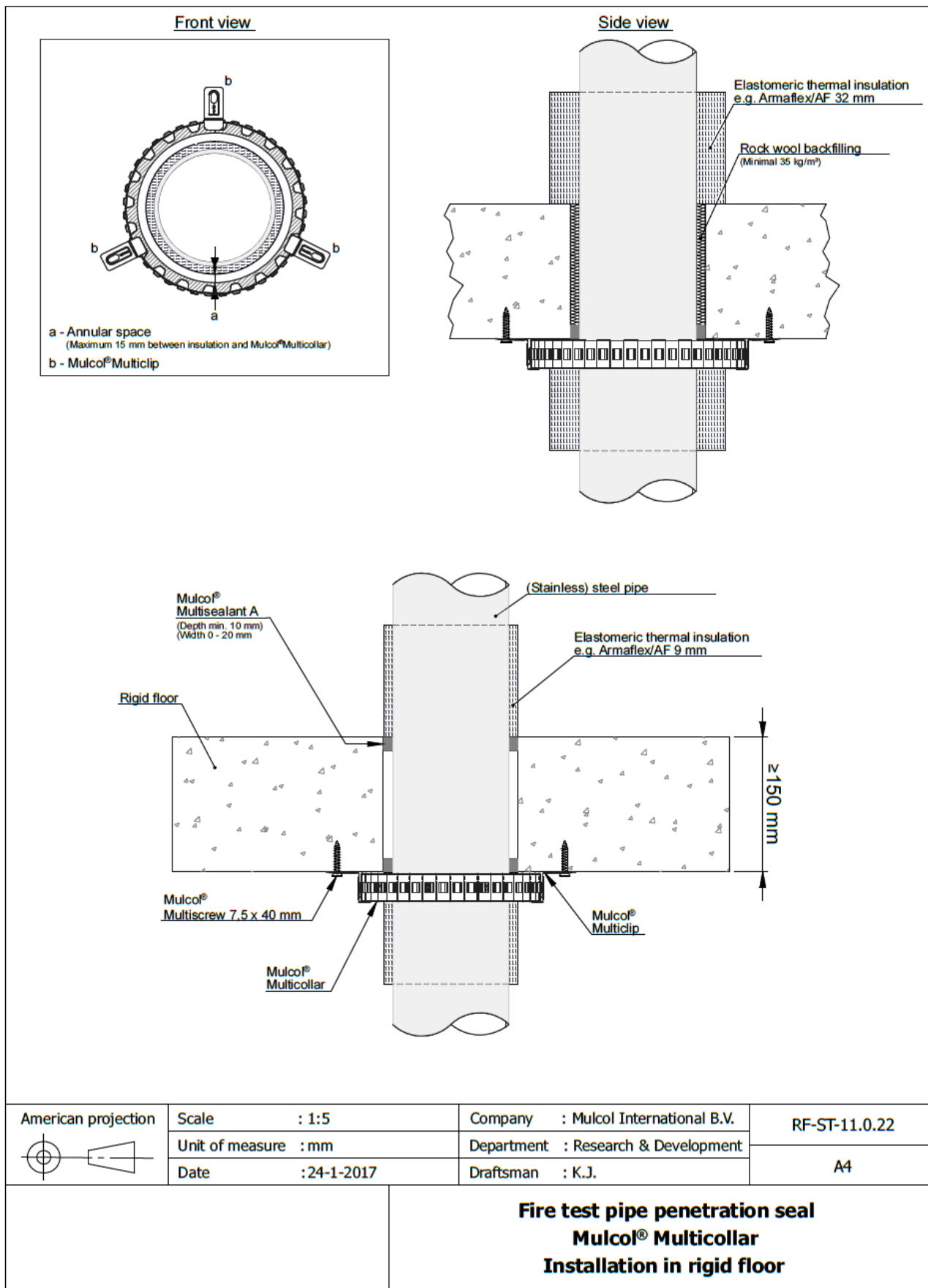

Pipe material	Maximum Pipe diameter mm	Pipe wall thickness mm	Insulation LI/CI thickness / length mm	No. of collars per face	Classification*
Steel / Iron / Stainless steel	114.3	3.6-14.2	9-32 / 500 (min.)	One	E 90 C/U EI 60 C/U
	168.3	4.5-14.2			
	114.3	3.6-14.2	32 / 500 (min.)		EI 90 C/U
	168.3	4.5-14.2			

* C/U pipe end configuration applies to C/C also

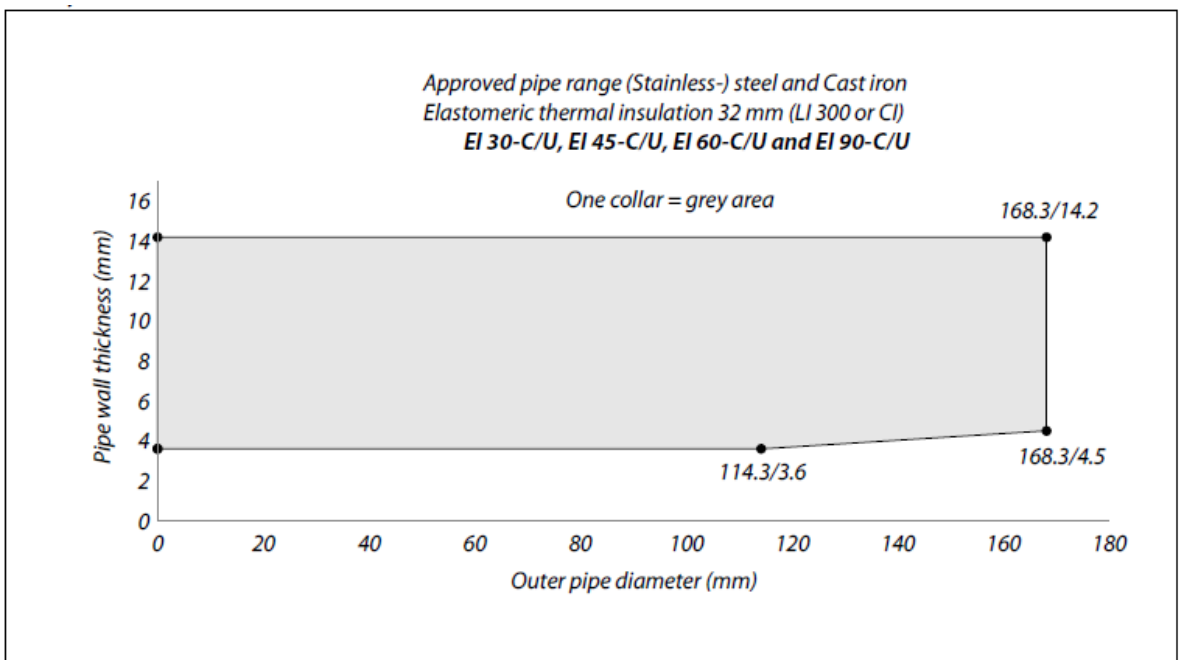
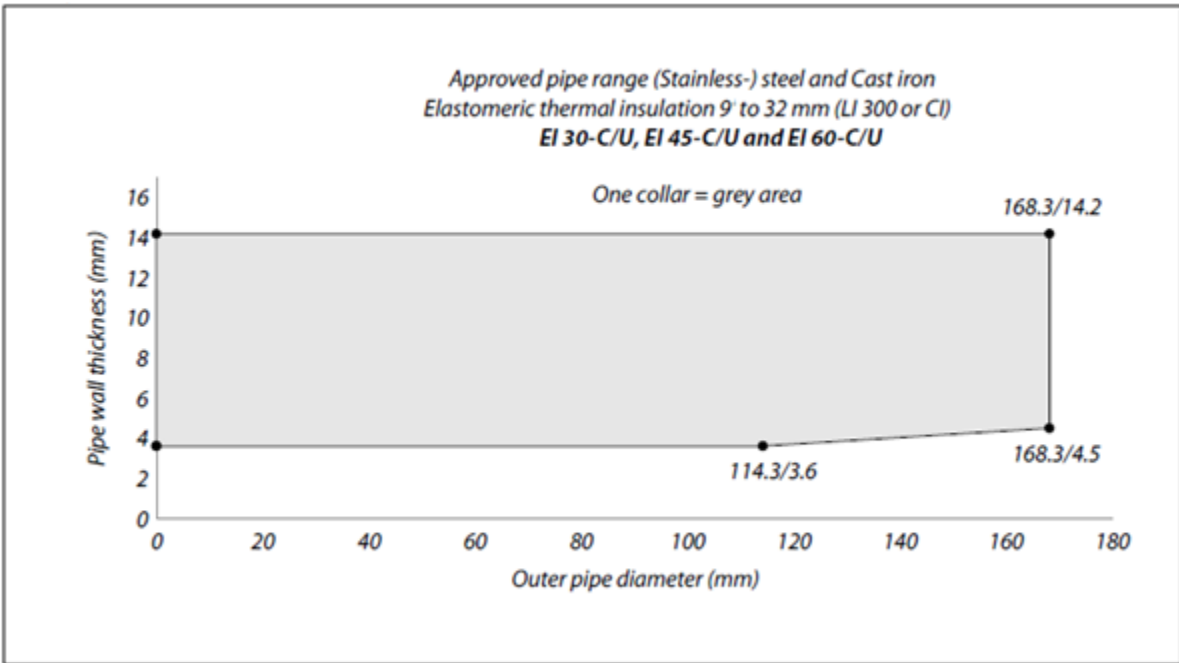

B.8.1.3 Metal pipes insulated with AF/Armaflex made out of flexible elastomeric EPDM rubber foam with min. reaction to fire class BL-s3, d0 or B-s3, d0 (EN 13501-1), fitted perpendicular to the floor, with one Mulcol® Multicollar Slim pipe collars to the soffit.

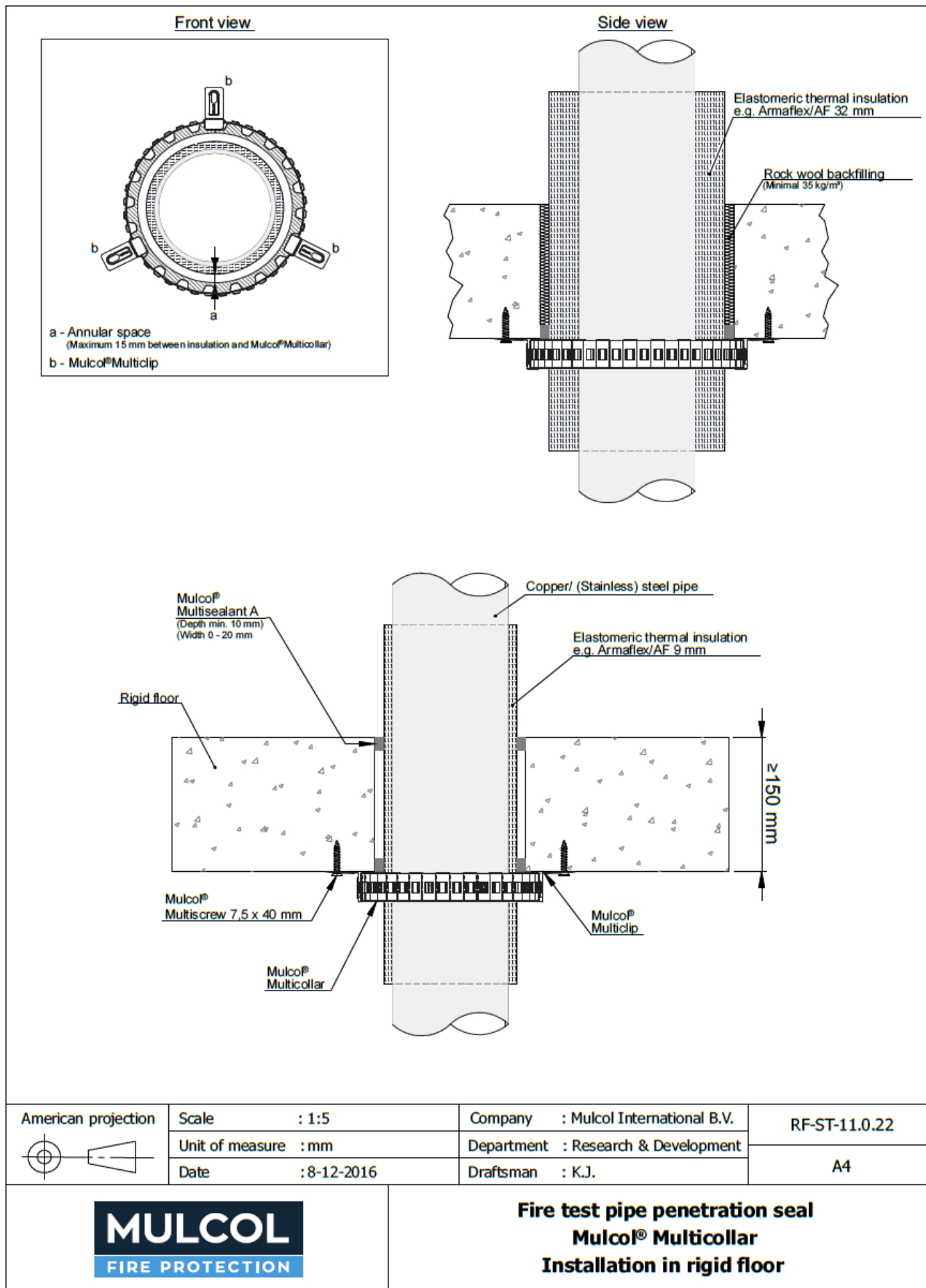

Pipe material	Maximum Pipe diameter mm	Pipe wall thickness mm	Insulation LS/CS thickness / length mm	No. of collars per face	Classification*
Copper / Steel / Iron / Stainless steel	88.9	2.0-14.2	32 / 450 (min.)	One	E 90 C/U EI 45 C/U
			32 / continuous (CS)		E 90 C/U EI 60 C/U
Steel / Iron /Stainless steel	114.3	3.6-14.2	9-32 / 450 (min.)		EI 60 C/U
	168.3	4.5-14.2			

* C/U pipe end configuration applies to C/C also

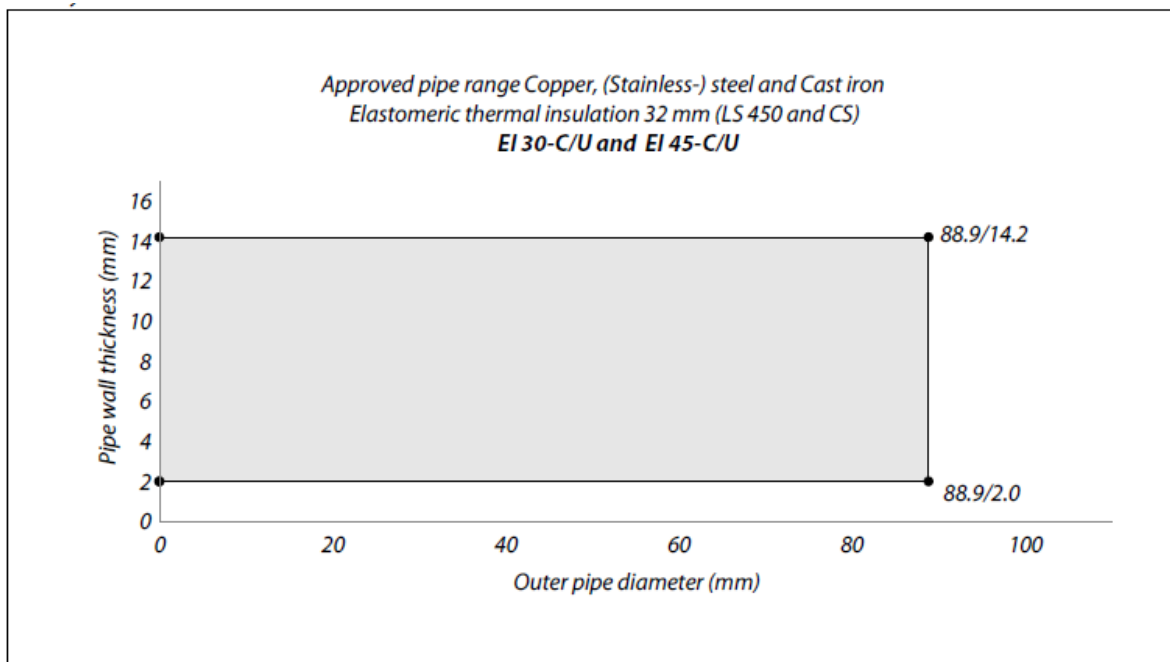

Approved pipe range Copper, (Stainless-) steel and Cast iron
Elastomeric thermal insulation 32 mm (CS)
EI 30-C/U, EI 45-C/U and EI 60-C/U

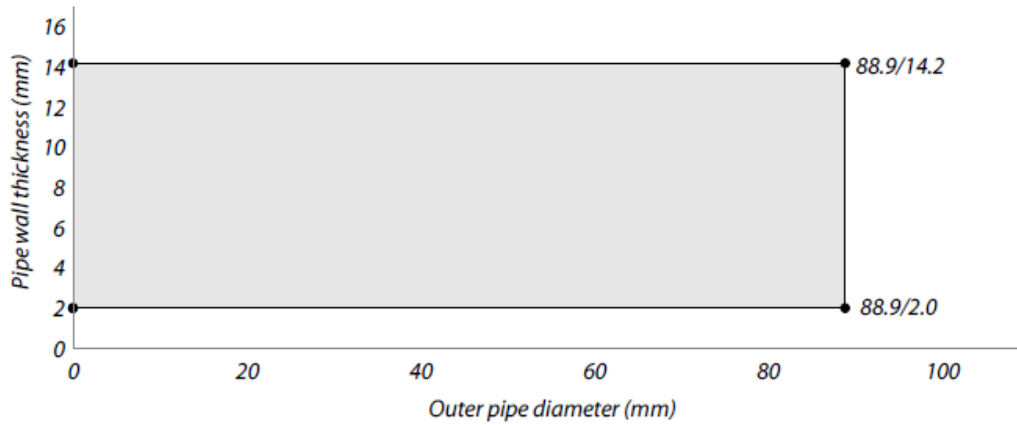

Approved pipe range (Stainless-) steel and Cast iron
Elastomeric thermal insulation 9 to 32 mm (LS 450 or CS)
EI 30-C/U, EI 45-C/U and EI 60-C/U

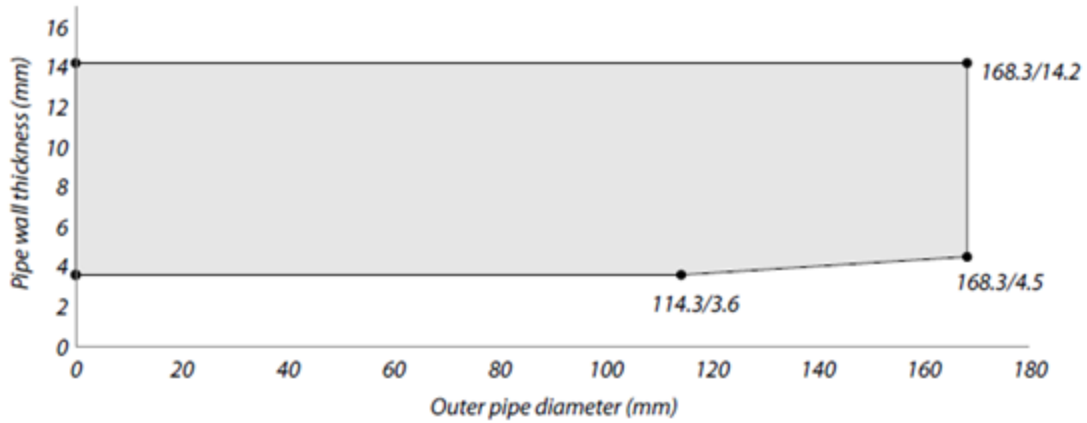

B.8.1.4 Metal pipes, perpendicular to the floor, in Mulcol® Multimastic FB1 coated board seals, with one Mulcol® Multicollar Slim pipe collars to the soffit.

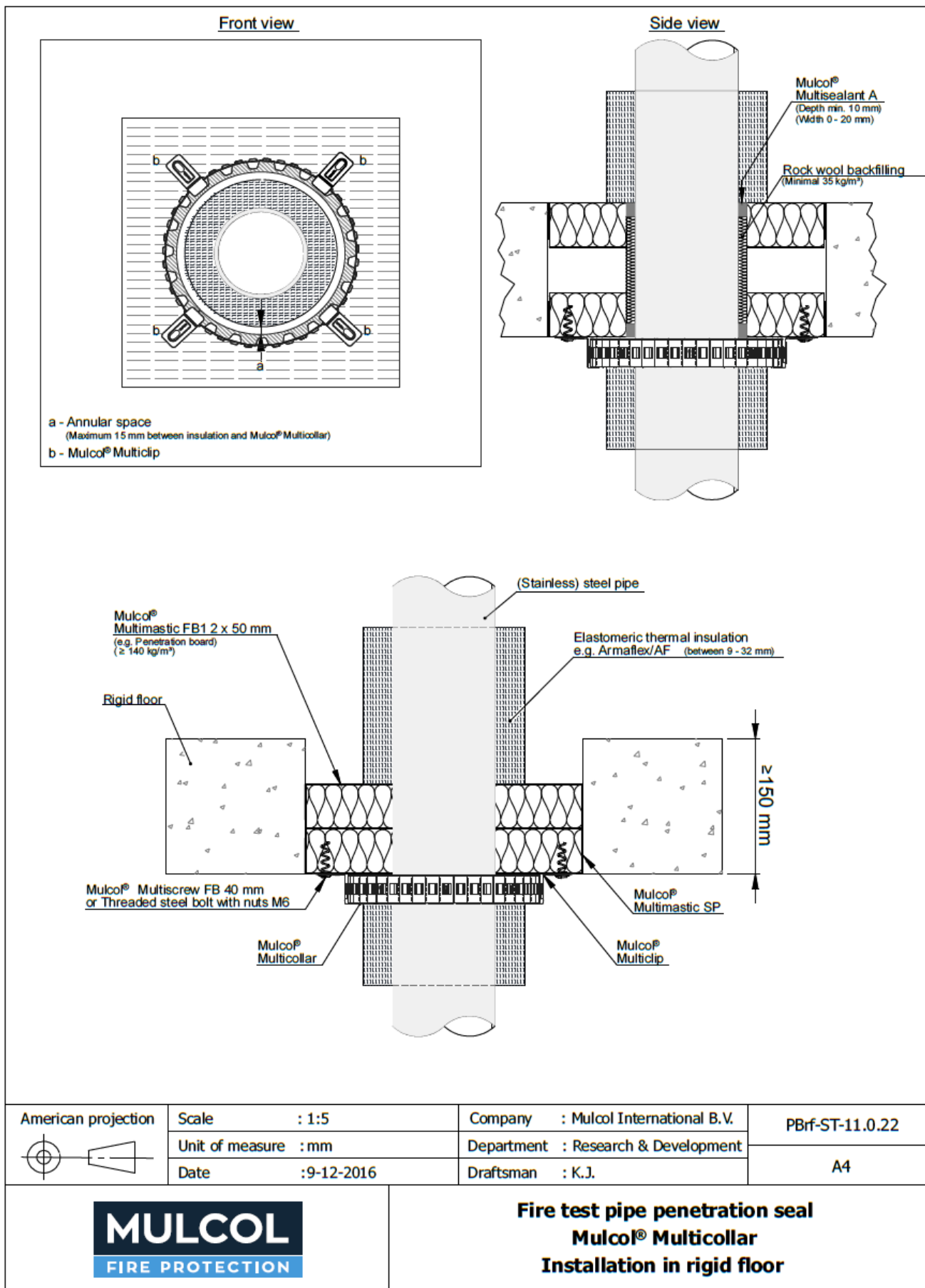

Pipe material	Maximum Pipe diameter mm	Pipe wall thickness mm	Insulation LI/CI thickness / length mm	No. of collars per face	Classification*
Steel / Iron / Stainless steel	114.3	3.6-14.2	9-32 / 300 (min.)	One	E 90 C/U EI 60 C/U
			32 / 300 (min.)		EI 90 C/U

* C/U pipe end configuration applies to C/C also

